



# **TECHNICAL MANUAL**

Installation, Operation and Maintenance Instructions

## **CA-3 and DA-3**

**Pot & Pan Washers**

Insinger Machine Company  
6245 State Road  
Philadelphia, PA 19135-2996

**800-344-4802**  
Fax: 215-624-6966  
[www.insingermachine.com](http://www.insingermachine.com)

*Thank you for purchasing a quality Insinger product.*

In the space provided below please record the model, serial number and start-up date of this unit:

Model: \_\_\_\_\_

Serial Number: \_\_\_\_\_

Start-Up Date: \_\_\_\_\_

When referring to this equipment please have this information available.

Each piece of equipment at Insinger is carefully tested before shipment for proper operation. If the need for service should arise please contact your local Authorized Insinger Service Company.

To find your local authorized Service Company please visit our web site, [www.insingermachine.com](http://www.insingermachine.com) or call Insinger at 800-344-4802.

For proper activation of the Insinger Limited Warranty, a SureFire™ Start-up should be completed on your machine. Refer to the Introduction section in this manual for an explanation of Insinger's SureFire™ Start-up and Check-out Program.

Please read the Insinger Limited Warranty and all installation and operation instructions carefully before attempting to install or operate your new Insinger product.

To register your machine for warranty, or for answers to question concerning installation, operation, or service contact our Technical Service Department.

<b>TECHNICAL SERVICE CONTACTS</b>	
Toll-Free	800-344-4802
Fax	215-624-6966
e-mail	<a href="mailto:service@insingermachine.com">service@insingermachine.com</a>
Web site	<a href="http://www.insingermachine.com">www.insingermachine.com</a>

## TABLE OF CONTENTS

<b>Part 1</b> <b>Technical Information</b> <ul style="list-style-type: none"> <li>• Specification Sheets</li> <li>• Introduction</li> <li>• Definitions</li> <li>• Safety Summary</li> <li>• Warranty</li> </ul>	1-6
<b>Part 2</b> <b>Installation Instructions</b> <ul style="list-style-type: none"> <li>• General Installation Instructions</li> <li>• Installation Drawings</li> </ul>	7-10
<b>Part 3</b> <b>Operation Instructions</b>	11
<b>Part 4</b> <b>Cleaning Instructions</b> <ul style="list-style-type: none"> <li>• Daily Cleaning Instructions</li> <li>• Weekly Cleaning Instructions</li> </ul>	12
<b>Part 5</b> <b>Maintenance and Repair Procedures</b> <ul style="list-style-type: none"> <li>• Maintenance Requirements</li> <li>• Maintenance Procedures</li> <li>• Troubleshooting</li> </ul>	13-20
<b>Part 6</b> <b>Replacement Parts &amp; Assemblies</b> <ul style="list-style-type: none"> <li>• Assembly Drawings with Parts Lists</li> </ul>	21-45
<b>Part 7</b> <b>Electrical Schematics and Parts</b> <ul style="list-style-type: none"> <li>• Electrical Schematics</li> <li>• Control Panel Layouts</li> </ul>	46-49



Project \_\_\_\_\_  
 Item \_\_\_\_\_  
 Quantity \_\_\_\_\_  
 CSI - 11400 \_\_\_\_\_  
 Approval \_\_\_\_\_  
 Date \_\_\_\_\_



## CA-3 Pot and Pan Washer

- Automatic door type pot, pan and utensil washer with timed wash and rinse cycle
- Capacity 25 (24" x 28") racks per hour or 150 bun/pans per hour or 100 steam table (2" thick) pans per hour
- Fully automatic operation with power on/off button
- Cycle starts when doors are closed
- Rinse pressure regulator
- Hold-Down Rack System for secure washing
- Rollers make getting large racks in and out easier
- Available for corner operation

### STANDARD FEATURES

- Wash tank heat: electric, steam injection
- Pressure regulator
- Single point electrical connection
- Low water protection
- Door safety switches
- 1 vent opening with adjustable damper
- Inspection door
- Vacuum breaker on all incoming water lines
- Capillary thermometer for wash and final rinse
- 304 stainless steel construction
- Stainless steel front panel
- Automatic fill
- Detergent connection provision
- Hold-down rack system
- Manual bypass selector switch
- Side-mounted control panel (NEMA 12)
- Simplified scrap screen design
- Interchangeable upper and lower spray arms
- Standard frame drip proof motor
- Rack assortment- 1 general utility, 1 bake sheet, 1 basket
- Manifold clean-out brush
- SureFire® Start-Up & Check-Out Service

### OPTIONS

- Stainless steel steam coil tank heat
- Steam booster
- Electric booster
- Security package
- Totally enclosed motor
- Pressure reduction valve and line strainer

### SPECIFIER STATEMENT

Specified unit will be an Insinger CA-3 pot and pan washer. Features include pressure regulation, low water protection, inspection door, vacuum breaker on incoming water lines, capillary thermometer, 304 stainless steel construction, automatic fill, hold-down rack system, manual bypass selector, and SureFire Start-Up & Check-Out service.



# Additional Information

Capacity Per Hour	25 racks/150 sheet pans
Tank Capacity	31 gallons
Motor Size	5 hp
Electric Usage (Electric booster must have 16 gallon holding tank)	5 kW wash tank 9 kW booster 40° rise 24 kW booster 70° rise
Steam Consumption at 20 psi	40° rise 20 lbs./hr. tank 25 lbs./hr. booster average 238 lbs./hr. booster peak
	70° rise 20 lbs./hr. tank 44 lbs./hr. booster average 417 lbs./hr. booster peak
Final Rinse Peak Flow at 20 psi min.	11.2 gallons/minute
Final Rinse Consumption at 20 psi min.	2.8 gallons/cycle 70 gallons/hour
Exhaust Requirements	300 CFM
Peak Rate Drain Flow	9 gallons/minute
Shipping Weight	800 lbs.

Current Draw Amps	Steam	Electric w/o booster
230/1/60	N/A	N/A
208/3/60	17.4	31.3
240/3/60	15.9	27.9
480/3/60	7.9	13.9
380/3/50	9.6	17.2

Note: Due to product improvement we reserve the right to change information and specifications without notice.

## SPECIFICATIONS

**CONSTRUCTION-** Hood and tank constructed of 16 gauge 18-8 type 304 S/S. Hood unit of all welded seamless construction. S/S frame, legs and feet. All internal castings are non-corrosive lead free nickel alloy or bronze.

**DOORS-** A front inspection/clean-out door and two simultaneously opening operating doors. Operating doors balanced by externally mounted springs. Extra large die formed 18-8 type 304 S/S doors ride in all S/S channels. A triple ply leading edge on the door channels made of S/S.

**PUMP-** Centrifugal type “packless” pump with a brass petcock drain. Construction includes ceramic seal and a balanced cast impeller on a precision ground stainless steel shaft, extension or sleeve. All working parts mounted as an assembly and removable as a unit without disturbing pump housing. One 5 hp motor, standard horizontal C-face frame, drip proof, internally cooled with ball-bearing construction.

**CONTROLS-** Side-mounted control cabinet, NEMA 12 rated, housing motor controls and overload protection, transformer, contactors and all dishwasher integral controls. All controls safe low voltage 24 VAC.

**SPRAY SYSTEM-** Wash and rinse spray systems made of 18-8 type 304 S/S pipe threaded into cast hub assemblies. Upper and lower spray assemblies are interchangeable and are removable without the use of tools.

**WASH-** 2 power spinning wash arms above and 2 power spinning wash arms below, each designed with 8 high pressure action cleansing holes.

**FINAL RINSE-** 2 power spinning wash arms above and 2 power spinning rinse arms below, each designed with 3 nozzles.

**DRAIN-** Drain valve externally controlled. Overflow assembly with skimmer cap is removable with the use of simple tools for drain line inspection. Heater is protected by low water level control.

\*Note: Exhaust requirements are for duct connections only.



Project \_\_\_\_\_  
Item \_\_\_\_\_  
Quantity \_\_\_\_\_  
CSI - 11400 \_\_\_\_\_  
Approval \_\_\_\_\_  
Date \_\_\_\_\_



## DA-3 Pot and Pan Washer

- Automatic double door type pot, pan and utensil washer with timed wash and rinse cycle
- Capacity 50 (24" x 28") racks per hour or 276 bun/pans per hour or 184 steam table (2" thick) pans per hour
- Fully automatic operation with power on/off button
- Cycle starts when doors are closed
- Rinse pressure regulator
- Hold-Down Rack System for secure washing
- Rollers make getting large racks in and out easier

### STANDARD FEATURES

- Wash tank heat: electric or steam injection
- Pressure regulator
- Single point electrical connection
- Low water protection
- Door safety switches
- 2 vent openings with adjustable damper
- Inspection door
- Vacuum breaker on all incoming water lines
- Capillary thermometer for wash and final rinse
- 304 stainless steel construction
- Stainless steel front panel
- Automatic fill
- Detergent connection provision
- Hold-down rack system
- Rollers for track
- Manual bypass selector switch
- Side-mounted control panel (NEMA 12)
- Simplified scrap screen design
- Interchangeable upper and lower spray arms
- Standard frame drip proof motor
- Rack assortment- 2 general utility, 2 bake sheets, 1 basket, 1 counter pan
- Manifold clean-out brush
- SureFire® Start-Up & Check-Out Service

### OPTIONS

- Stainless steel steam coil tank heat
- Steam booster
- Electric booster
- Security package
- Totally enclosed motor
- Pressure reduction valve and line strainer

### SPECIFIER STATEMENT

Specified unit will be an Insinger DA-3 pot and pan washer. Features include pressure regulator, low water protection, door safety switches, inspection door, vacuum breaker on water lines, capillary thermometer, 304 stainless steel construction, automatic fill, hold-down rack system, and SureFire Start- Up & Check-Out service.



# Additional Information

Capacity Per Hour	50 racks/276 sheet pans
Tank Capacity	62 gallons
Motor Size	(2) 5 hp
Electric Usage (Electric booster must have 16 gallon holding tank)	5 kW wash tank (2) 9 kW booster 40° rise (2) 24 kW booster 70° rise
Steam Consumption at 20 psi	40° rise 20 lbs./hr. tank 50 lbs./hr. booster average 476 lbs./hr. booster peak  70° rise 20 lbs./hr. tank 88 lbs./hr. booster average 834 lbs./hr. booster peak
Final Rinse Peak Flow at 20 psi min.	22.4 gallons/minute
Final Rinse Consumption at 20 psi min.	5.6 gallons/cycle 140 gallons/hour
Exhaust Requirements	600 CFM
Peak Rate Drain Flow	16 gallons/minute
Shipping Weight	1500 lbs.

Current Draw Amps	Steam	Electric w/o booster
208/3/60	34.1	48.0
230/1/60	N/A	N/A
240/3/60	31.1	43.1
480/3/60	15.5	21.5
380/3/50	18.8	26.4

Note: Due to product improvement we reserve the right to change information and specifications without notice.

## SPECIFICATIONS

**CONSTRUCTION-** Hood and tank constructed of 16 gauge 18-8 type 304 S/S. Hood unit of all welded seamless construction. S/S frame, legs and feet. All internal castings are non-corrosive lead free nickel alloy or bronze.

**DOORS-** A front inspection/clean-out door and two simultaneously opening operating doors. Operating doors balanced by externally mounted springs. Extra large die formed 18-8 type 304 S/S doors ride in all S/S channels. A triple ply leading edge on the door channels made of S/S.

**PUMP-** Centrifugal type “packless” pump with a brass petcock drain. Construction includes ceramic seal and a balanced cast impeller on a precision ground stainless steel shaft, extension or sleeve. All working parts mounted as an assembly and removable as a unit without disturbing pump housing. One 5 hp motor, standard horizontal C-face frame, drip proof, internally cooled with ball-bearing construction.

**CONTROLS-** Side-mounted control cabinet, NEMA 12 rated, housing motor controls and overload protection, transformer, contactors and all dishwasher integral controls. All controls safe low voltage 24 VAC.

**SPRAY SYSTEM-** Wash and rinse spray systems made of 18-8 type 304 S/S pipe threaded into cast hub assemblies. Upper and lower spray assemblies are interchangeable and are removable without the use of tools.

**WASH-** 2 power spinning wash arms above and 2 power spinning wash arms below, each designed with 8 high pressure action cleansing holes.

**FINAL RINSE-** 2 power spinning wash arms above and 2 power spinning rinse arms below, each designed with 3 nozzles.

**DRAIN-** Drain valve externally controlled. Overflow assembly with skimmer cap is removable with the use of simple tools for drain line inspection. Heater is protected by low water level control.

\*Note: Exhaust requirements are for duct connections only.

## CA-3 & DA-3 POT AND PAN WASHERS

### INTRODUCTION

This manual contains all pertinent information to assist in the proper installation, operation, cleaning, maintenance, and parts ordering for the CA-3 and DA-3 pot and pan washers.

The installation instructions are intended for qualified equipment installers.

The operation and cleaning instructions are intended for the daily users of the equipment.

The maintenance and drawing sections are intended for qualified service and/or maintenance technicians.

Replacement parts may be ordered directly from our factory or from your local Authorized Insinger Service Company.

### Surefire™ Start-Up Program

Insinger is proud to offer our exclusive Surefire™ Start-up & Check-out Program to our commercial customers. This service is included in the purchase price of your new Insinger dishwasher. We will provide an authorized factory service technician for the initial start-up of your new Insinger dishwasher to ensure it is running correctly. Please call the factory or your local Insinger Sales or Service Representative to schedule this service.

### NSF 3 requirements for detergent and chemical sanitizer dispensers

This machine must be operated with an automatic detergent feeder and, if applicable, an automatic chemical sanitizer feeder, including a visual means to verify that detergents and sanitizers are delivered or a visual or audible alarm to signal if detergents and sanitizers are not available for delivery to the respective washing system. Please see instructions for electrical and plumbing connections located in this manual and in the feeder equipment manual.

### Intended Use

Insinger dishmachines may only be used for cleaning plates, cups, dishes, cutlery and similar restaurant ware and commercial catering.

Any change in design or use of the dishwasher carried out without the written permission of Insinger, will lead to warranty nullification.

If damage is caused to the dishwasher due to failure to observe the instructions given in this manual, no claims under the warranty agreement can be submitted to Insinger Machine Company.

### DEFINITIONS



Throughout this guide you will find the following terms: **WARNING, CAUTION, & NOTE.**

**WARNING** indicates potential physical danger.

**CAUTION** indicates potential equipment damage.

**NOTE** indicates helpful operating hints or tips.

You will visually be able to identify each as shown below:

	<b>WARNING:</b> Indicates potential physical danger.
<b>CAUTION:</b>	
Indicates potential equipment damage.	
	<b>NOTE:</b> Indicates helpful operating hints or tips.

### SAFETY SUMMARY

The following are general safety precautions that are not related to any specific procedures. These are recommended precautions that personnel must understand and apply during many phases of operation and maintenance.

#### Keep Away From Live Circuits

Operating personnel must at all times observe all safety regulations. Do not replace components or make adjustments inside the equipment with the power supply turned on. Under certain conditions, dangerous potentials may exist when the power control is in the off position. To avoid casualties and injuries, always remove power, red tag and lockout machine, and ground a circuit before touching it.

#### Do Not Service or Adjust Alone

Under no circumstances should any person reach into or enter the enclosure for the purpose of servicing or adjusting the equipment except in the presence of someone who is capable of rendering aid.

#### Resuscitation

Personnel working with or near high voltages should be familiar with modern methods of resuscitation. Such information may be obtained from the Bureau of Medicine and Surgery.

**INSINGER MACHINE COMPANY LIMITED WARRANTY**

Insinger Machine Company, Inc. (Insinger) hereby warrants to the original retail purchaser of this Insinger Machine Company, Inc. product, that if it is assembled and operated in accordance with the printed instructions accompanying it, then for a period of either 15 months from the date of shipment from Insinger or 1 year (12 months) from the date of installation or start-up that said Insinger product shall be free from defects in material and workmanship. Whichever one of the two aforesaid limited warranty time periods is the shortest shall be the applicable limited warranty coverage time period.

Insinger may require reasonable proof of your date of purchase; therefore, you should retain your copy of invoice or shipping document.

This limited warranty shall be limited to the repair or replacement of parts which prove defective under normal use and service and which on examination shall indicate, to Insinger's satisfaction, they are defective. Any part that is claimed to be defective and covered by this limited warranty must be returned to Insinger. An RMA# must be obtained from the Insinger Warranty Department before returning any material. Return may be done through an Authorized Service Agency. Furnish serial number of machine and RMA # with shipment and send to:

Insinger Machine Company  
6245 State Road  
Philadelphia, PA 19135-2996

If Insinger's inspection confirms the defect and the claim, Insinger will repair or replace such part without charge and return it to you freight or postage prepaid.

This limited warranty does not cover any failure or accident, abuse, misuse, alteration, misapplication, improper installation, fire, flood, acts of God or improper maintenance or service, or failure

to perform normal and routine maintenance as set out in the instruction booklet (operating instructions) or for improper operation or failure to follow normal operating instructions (as set out in the instruction booklet). Insinger is not responsible nor liable for any conditions of erosion or corrosion caused by corrosive detergents, acids, lye or other chemicals used in the washing and or cleaning process.

Service must be done by either Insinger Appointed Service Agencies or agencies receiving prior authorization from Insinger.

All warranty work must be done during normal working hours, unless purchaser receives prior authorization from Insinger.

There are no other express warrants except as set forth herein and any applicable implied warranties of merchantability and fitness are limited in duration to the period of coverage of this express written limited warranty. This limited warranty supersedes all other express warranties, implied warranties of merchant-ability and fitness or limited warranties as of this date, January 1, 1998. Some states do not allow limitation on how long an implied warranty lasts so this limitation may not apply to you.

Insinger is not liable for any special, indirect or consequential damages. Some states do not allow the exclusion or limitation of incidental or consequential damages, so this limitation nor exclusion may not apply to you.

Insinger does not authorize any person or company to assume for it any other obligation or liability in connection with the sale, installation, use, removal, return or replacement of its equipment: and no such representations are binding on Insinger.



**CA-3 & DA-3 POT AND PAN WASHERS  
INSTALLATION INSTRUCTIONS**

These installation instructions are intended for qualified equipment installers.

**PLACEMENT**

Carefully uncrate the machine. Take caution not to damage components which may be mounted on the top or sides of the machine.

Set unit in place and adjust the feet to level the machine.

**TABLING**

Load and unload tables should be pitched towards the machine to return excess water into the machine.

Fasten the tables to the load and unload side of the machine. Most installations require fastening the turn-down lip of the dish tables to the side of the machine with flathead counter-sunk screws.

The table design should provide horizontal clearance of 30" for servicing.

**ELECTRICAL CONNECTIONS**

Connect electrical lines sized for the correct voltage, current and phase of the machine. These should agree with the machine requirements indicated on the nameplate and labels on the control panel. The below Fuse Sizing Chart should be used as a guide for proper line protection.

Machines not provided with a single-point connection require two separate electrical connections for:

1. pumps and control circuit
2. wash tank heater(s)

If an electrical booster is provided connect the power directly to the booster.

**CAUTION:**

Connections must be made to a circuit breaker or fused disconnect as provided by the end-user and required by local codes. A laminated wiring diagram is inside the control panel.

**CAUTION:**

As with any 3 phase system, an electrician must check all motors for proper phasing, i.e., Pump motors must be running in direction indicated by arrow on housing.

**FUSE SIZING CHART**

MODEL	TYPE	208VAC / 3PH	230VAC / 3PH	380VAC / 3PH	460VAC / 3PH
<b>CA-3(C)</b>	<b>Steam Heat</b>	25A	20A	15A	10A
	<b>Electric Heat</b>	35A	35A	20A	20A
	<b>Gas Heat</b>	25A	20A	15A	10A
<b>DA-3</b>	<b>Steam Heat</b>	40A	35A	25A	20A
	<b>Electric Heat</b>	60A	50A	30A	25A

**MECHANICAL CONNECTIONS**

Flush all lines to remove debris.

Connect 140°F water lines for tank fills/booster as tagged and noted on the installation drawings.

If machine is provided with steam heat, connect the steam lines and steam condensate lines as tagged and noted on installation drawings.

Connect the drain lines.

**CAUTION:**

Drain lines must be as specified on installation drawings. Drain line should be properly vented and should have fall of not less than 1/4" to the foot of proper flow.

**CAUTION:**

Some area plumbing codes require drains to flow into an open gap with an opening twice the diameter of the pipe. Check with your local plumbing codes for the type of drain connection required.

**CAUTION:**

Do not reduce the size of lines as specified in installation drawings. All lines are sized to facilitate necessary flows, pressures, etc.

**HVAC**

Ventilation system should be sized to provide adequate ventilation per machine specs. Refer to spec sheet.

**CHEMICALS**

Upon completed installation of the dishmachine, contact a local detergent/chemical supplier for the correct chemicals for your machine.

Electrical connection points for the detergent dispenser and rinse injector are located inside the control panel. Refer to the machine wiring diagram for the proper connection points.

Dispensers may be connected on either the primary voltage side of the machine or the 24VAC control voltage side.

**CAUTION:**

When connecting on the 24VAC control voltage side of the transformer, total KVA must not exceed 50VA.

The detergent density probe should be placed in the hole provided.

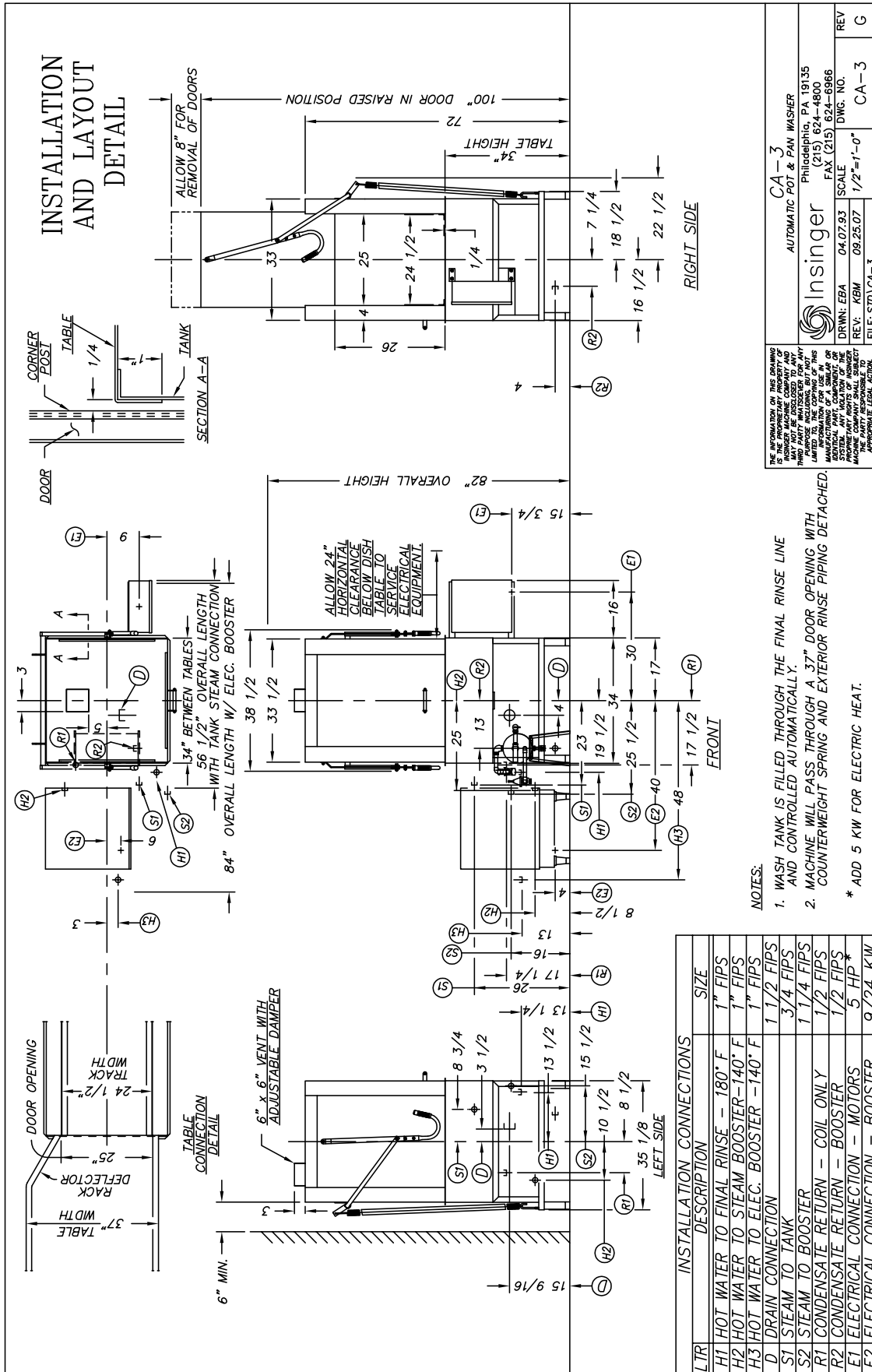

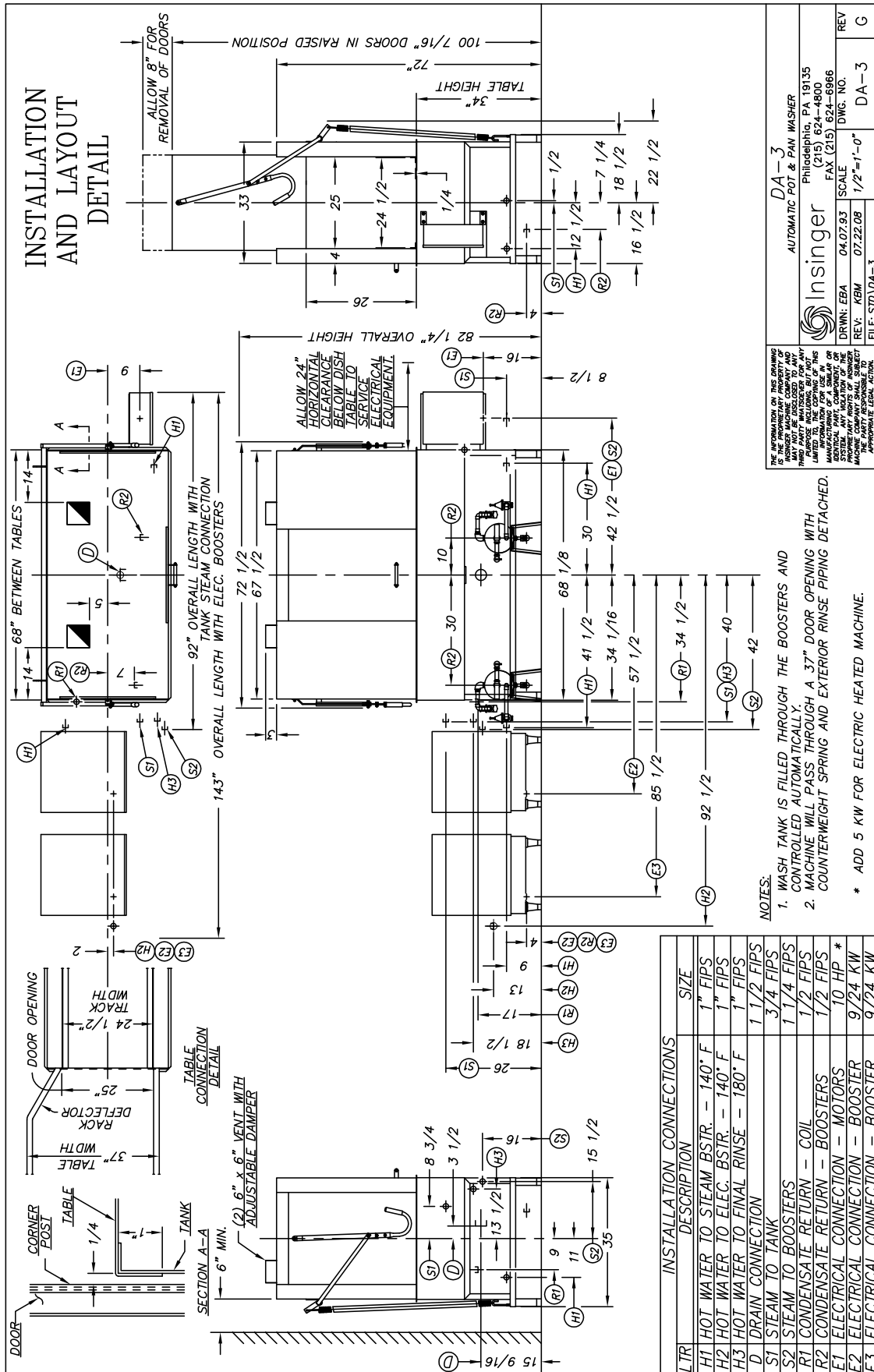

THE INFORMATION ON THIS DRAWING IS THE PROPRIETARY PROPERTY OF INSINGER AND IS NOT TO BE DISCLOSED TO ANY OTHER PARTY WITHOUT THE WRITTEN CONSENT OF INSINGER. THIS DRAWING IS LIMITED TO THE OPERATION OF THE AUTOMATIC POT AND PAN WASHER MANUFACTURED BY INSINGER. ANY MODIFICATION OF THE SYSTEM OR THE USE OF OTHER THAN INSINGER COMPONENTS SHALL BE AT THE USER'S RISK. INSINGER ASSUMES NO LIABILITY FOR ANY INFORMATIONAL ERROR.

DA-3  
 AUTOMATIC POT & PAN WASHER  
 Philadelphia, PA 19135  
 (215) 624-4800  
 FAX (215) 624-6966  
 DRWN: EBA 04.07.93 SCALE 1/2"=1'-0"  
 REV: KBM 07.22.08  
 FILE: STD\DA-3

LTR	DESCRIPTION	SIZE
H1	HOT WATER TO STEAM BSTR. - 140° F	1" FIPS
H2	HOT WATER TO ELEC. BSTR. - 140° F	1" FIPS
H3	HOT WATER TO FINAL RINSE - 180° F	1" FIPS
D	DRAIN CONNECTION	1 1/2" FIPS
S1	STEAM TO TANK	3/4" FIPS
S2	STEAM TO BOOSTERS	1 1/4" FIPS
R1	CONDENSATE RETURN - COIL	1/2" FIPS
R2	CONDENSATE RETURN - BOOSTERS	1/2" FIPS
E1	ELECTRICAL CONNECTION - MOTORS	10 HP *
E2	ELECTRICAL CONNECTION - BOOSTER	9/24 KW
E3	ELECTRICAL CONNECTION - BOOSTER	9/24 KW

NOTES:  
 1. WASH TANK IS FILLED THROUGH THE BOOSTERS AND CONTROLLED AUTOMATICALLY.  
 2. MACHINE WILL PASS THROUGH A 37" DOOR OPENING WITH COUNTERWEIGHT SPRING AND EXTERIOR RINSE PIPING DETACHED.  
 \* ADD 5 KW FOR ELECTRIC HEATED MACHINE.

## **CA-3 & DA-3 POT AND PAN WASHERS**

### **OPERATION INSTRUCTIONS**

These instructions are intended for the daily users of this machine.

#### **PREPARING MACHINE**

1. Ensure drain overflow tube is in place. Close the tank drain valve.
2. Check for proper installation and cleanliness of all internal, removable components such as suction strainers, scrap screens, and rotating spray pipes.
3. Ensure all water and steam lines are open.
4. Ensure electrical circuits are on.
5. Close machine doors.

#### **STARTING MACHINE**

1. Move the power toggle switch to the ON position. The machine will fill the tank, run through a complete wash/rinse cycle and shut-off.
2. When the tank is full the tank heat will operate automatically. Proper tank heat is 150°F.

#### **CAUTION:**

To ensure proper operation of the auto tank fill feature and the tank heaters, the level float located in each tank **MUST** be cleaned daily.

#### **WASHING WARE**

1. Open doors.
2. Insert a rack of soiled dishware in machine (two racks for the DA-3) and lower doors.
3. Machine will wash and rinse automatically.
4. When the rinse indicator light goes off the cycle is complete.
5. Raise doors and remove rack of clean ware.
6. For continuous operation repeat steps 2-5.



#### **NOTE:**

Overloading racks will minimize the proper cleaning of ware.

#### **SHUTDOWN**

1. Upon completion of ware cleaning, move the power toggle switch to the OFF position.
2. Drain the machine.
4. Refer to the CLEANING INSTRUCTIONS for proper clean-up of the dishmachine.
5. Report any unusual occurrences to qualified service personnel.

**CA-3 & DA-3 POT AND PAN WASHERS  
CLEANING INSTRUCTIONS**
**DAILY CLEANING**

The following cleaning procedures should be done daily, at the end of the shift:

1. Remove all internal removable parts including rotating spray pipes, scrap screens, drain overflow tubes, suction strainers and curtains.
2. Remove the end caps from the spray manifolds and clean with the brush provided. Flush the manifolds.

**CAUTION:**

Do not remove wash and rinse spray arms from the hubs as these are factory set. Cleaning should be done by removing the endcap on each arm.

3. Flush scrap screens of matter.
4. Clean drain overflow tube.

**CAUTION:**

V-cup seal on the drain overflow tube may become gummed which will not allow the overflow tube to seat properly. This will cause the drain to leak water. Remove any build-up on the V-cup seal. When the seal becomes worn, replace.

5. Clean suction strainers of build-up.

**CAUTION:**

Improper cleaning of suction strainers will cause the pumps to cavitate. This will cause poor washing results.

6. Clean tank level floats (1 per tank) with a plastic abrasive pad. DO NOT use steel wool.

**CAUTION:**

Level floats must be cleaned daily. Build-up of grease and scum will cause faulty operation of tank fill and heating system.

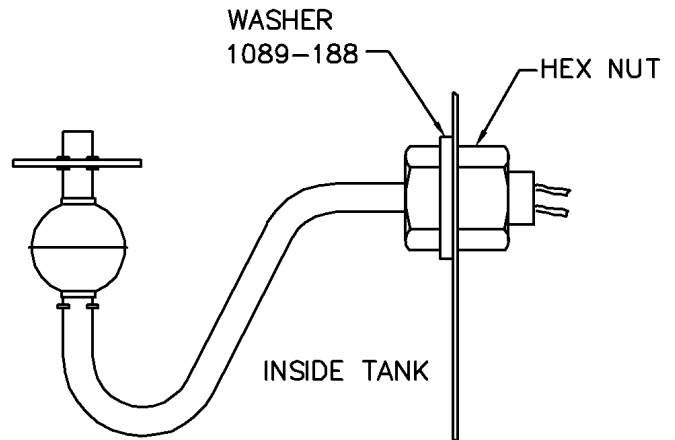

**DE5-60:** Liquid Level Float

7. Rinse nozzles should be cleaned of matter.
8. Doors should be left open to allow drying of interior surfaces.

**WEEKLY CLEANING**

1. The entire machine should be wiped down using an industrial grade stainless steel cleaner.
2. Under the supervision of your detergent supplier the machine interior must be properly de-limed.
3. The switch on the control panel labelled MANUAL and the switch labelled WASH should be used when de-liming the machine. When activated, these switches keep the machine in an indefinite wash cycle. This feature can also be used to wash heavily soiled ware.

**NOTE:**

The water quality in some areas requires de-liming to be done more frequently. Contact your detergent supplier for recommended de-liming frequency.

## CA-3 & DA-3 POT AND PAN WASHERS

### MAINTENANCE REQUIREMENTS

This section is intended for qualified service and/or maintenance technicians.

The following maintenance should be conducted quarterly:

1. Remove and clean the strainer screens on water and steam lines. If the screens cannot be cleaned, replace.
2. Inspect the condition of the fill solenoid valve seats and diaphragms. Replace as necessary.
3. Inspect drain O-Rings for leakage. Replace where necessary.
4. Check door spring tension and adjust where necessary.
5. Check wash and rinse hub bushing/bearing and replace where necessary.

### MAINTENANCE PROCEDURES

#### Solenoid Valve Disassembly (SK-5825)

1. Disconnect the power supply to the machine.
2. Turn off the water supply.
3. Remove cap on top of the coil. Remove the coil.
4. Remove the 4 hex bolts and lift bonnet from valve body. Note positioning of spring and plunger.
5. Remove main piston.
6. Inspect for dirt, wear or lime build-up. Clean or replace as required.
7. Reassemble in reverse of disassembly.

#### Line Strainer Disassembly

1. Shut off water supply.
2. Remove large hex nut on bottom of strainer body.
3. Remove strainer screen. Inspect and clean or replace as necessary.
4. Reassemble in reverse of disassembly. Water flow must be same direction as arrow on line strainer body. Use new gaskets to insure a tight seal.

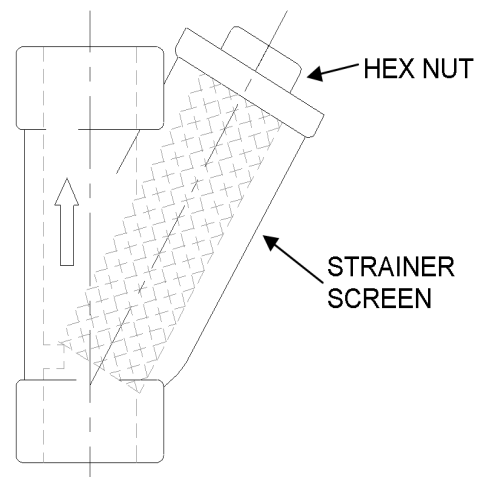

Line Strainer Assembly

### Pump Disassembly

1. Before disassembling pump ensure there are no obstructions in the pump intake by removing and cleaning the suction strainer (inside tank).



#### NOTE:

It is not necessary to remove the pump housing from the machine to disassemble the pump.

2. Remove the pump motor and impeller adaptor by removing the 4 hex bolts attaching them to the pump housing.
3. Repair or replace the pump parts as required.
4. Reassemble in reverse of disassembly.

### Wash and Rinse Cycle

1. The timing sequence consists of two timers.
2. The CA-3, CA-3C, and DA-3 use a five minute timer adjusted to 120 seconds for the wash cycle (P/N DE7-28)
3. They also use a one minute timer adjusted to 15 seconds for the rinse (P/N DE7-27).
4. Should either of these become defective, replace.

### Tank Heat Temperature Adjustment

A temperature control board is provided in the control panel for easy adjustment of tank temperature. Though tank temperature is set during factory testing it is sometimes necessary to re-adjust the temperature at start-up.

1. Locate the temperature control board (P/N DE9-251). Use the control panel layout drawing located in PART 7, Electrical Schematics and Parts.
2. Adjust the tank temperature to the correct temperature by turning the potentiometer located on the temperature control board. An arrow on the potentiometer indicates increase.

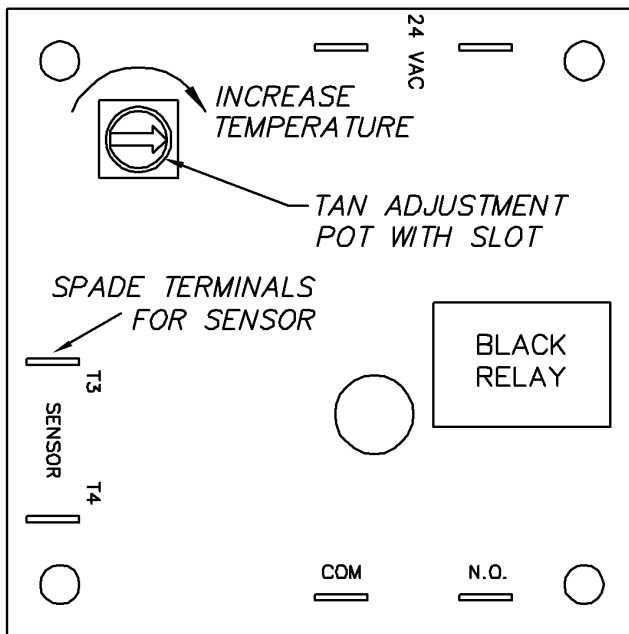

**DE9-251:** Tank Temperature Control Board

### Troubleshooting Tank Temperatures

If the temperature does not change follow the below procedures.

#### Electric Heat:

1. Check the temperature control board (P/N DE9-251) for proper operation. If the temperature control board is faulty, replace.
2. Verify tank heat contactor is working correctly. If not, replace.
3. Verify all immersion heaters are working properly and are not limed. If not, replace.

#### Steam Heat:

1. Check the temperature control board (P/N DE9-251) for proper operation. If the temperature control board is faulty, replace.
2. Verify steam pressure per machine specifications.
3. Verify steam trap is not clogged. If so, clean and/or replace.

### Immersion Heater Replacement (SK-4703)

1. The immersion heater **MUST** be completely submerged at all times. If this is not the case contact a qualified service technician. The heated surface should never be in contact with sludge.
2. Remove the housing covering the wiring terminations. Disconnect the immersion heater wires.
3. Remove the immersion heater by loosening and removing the large hex nut.
4. Install in reverse of removal.



#### **NOTE:**

Use plumbers putty as gasketing around the immersion heater installation nut.



### Motor Overloads

All motors used on Insinger Machines are provided with motor overloads. Motor overloads are adjusted when the machines are factory tested. Should it be necessary to adjust the motor overloads in the field first verify the motor current draw for the voltage the machine is using.

Refer to the Control Panel Layout drawing located in PART 7 to identify the overload, adjust by turning the dial to the appropriate AMP draw.

### Level System

The level control system consists of one level timer (P/N DE7-35) and one level float (DE5-60) per tank.

When the system is powered-up, the tank(s) will begin to fill (assuming no water is in the tanks).

Once the level float is actuated, the timer begins to time-out and continues the filling process until the tank(s) is full.

Should the tank heat energize without water in the tank troubleshoot the system to find the problem

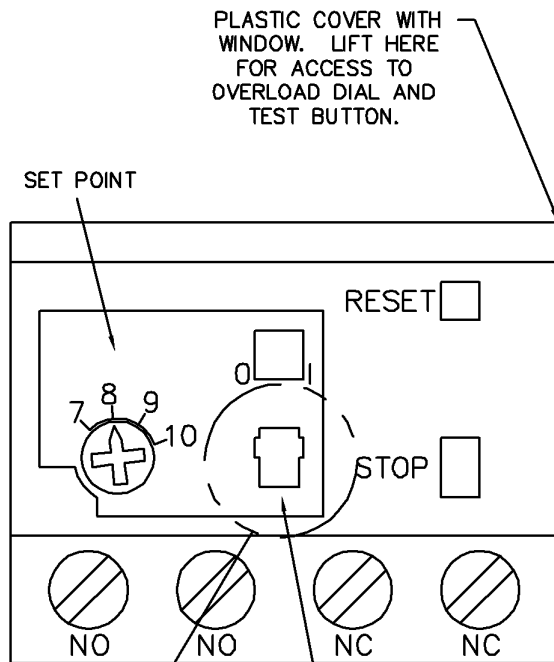

RESET SELECTOR WINDOW (AUTO RESET MODE SHOWN)

TO CHANGE FROM MANUAL TO AUTO RESET:

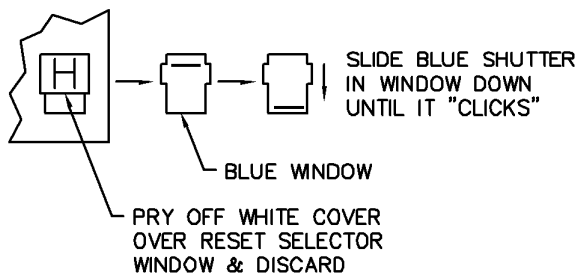

Motor Overload Relay

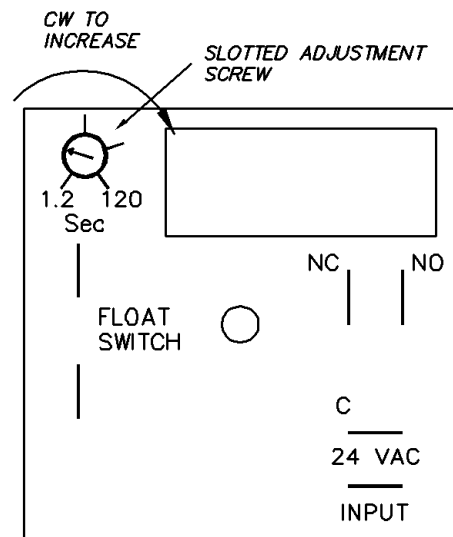

DE7-35: Liquid Level Timer

### CAUTION:

Dirty level floats will cause the tank heat to energize with no water in the tanks. Level floats **MUST** be cleaned daily.

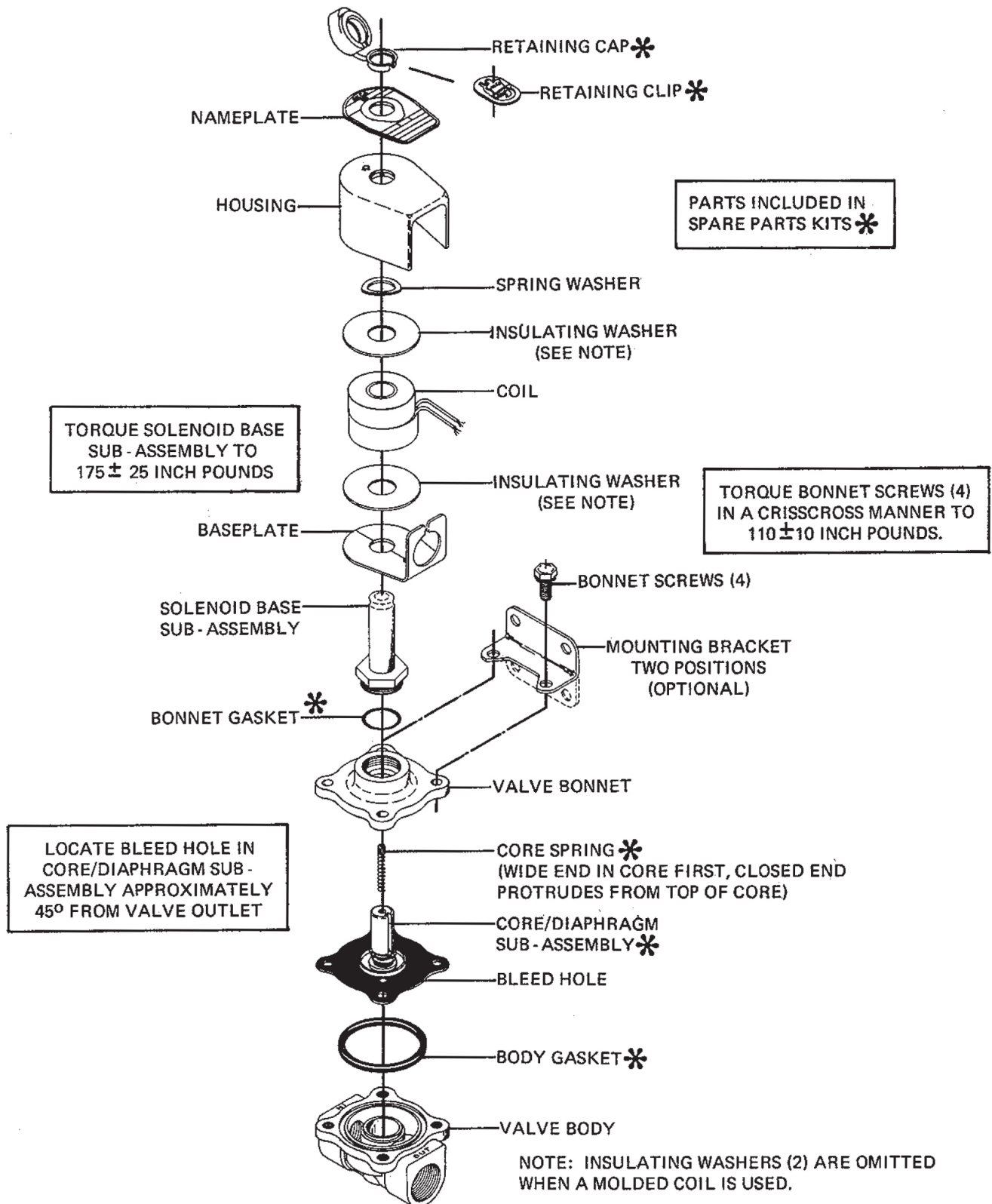
**SK-5825 : Final Rinse Solenoid Valve**

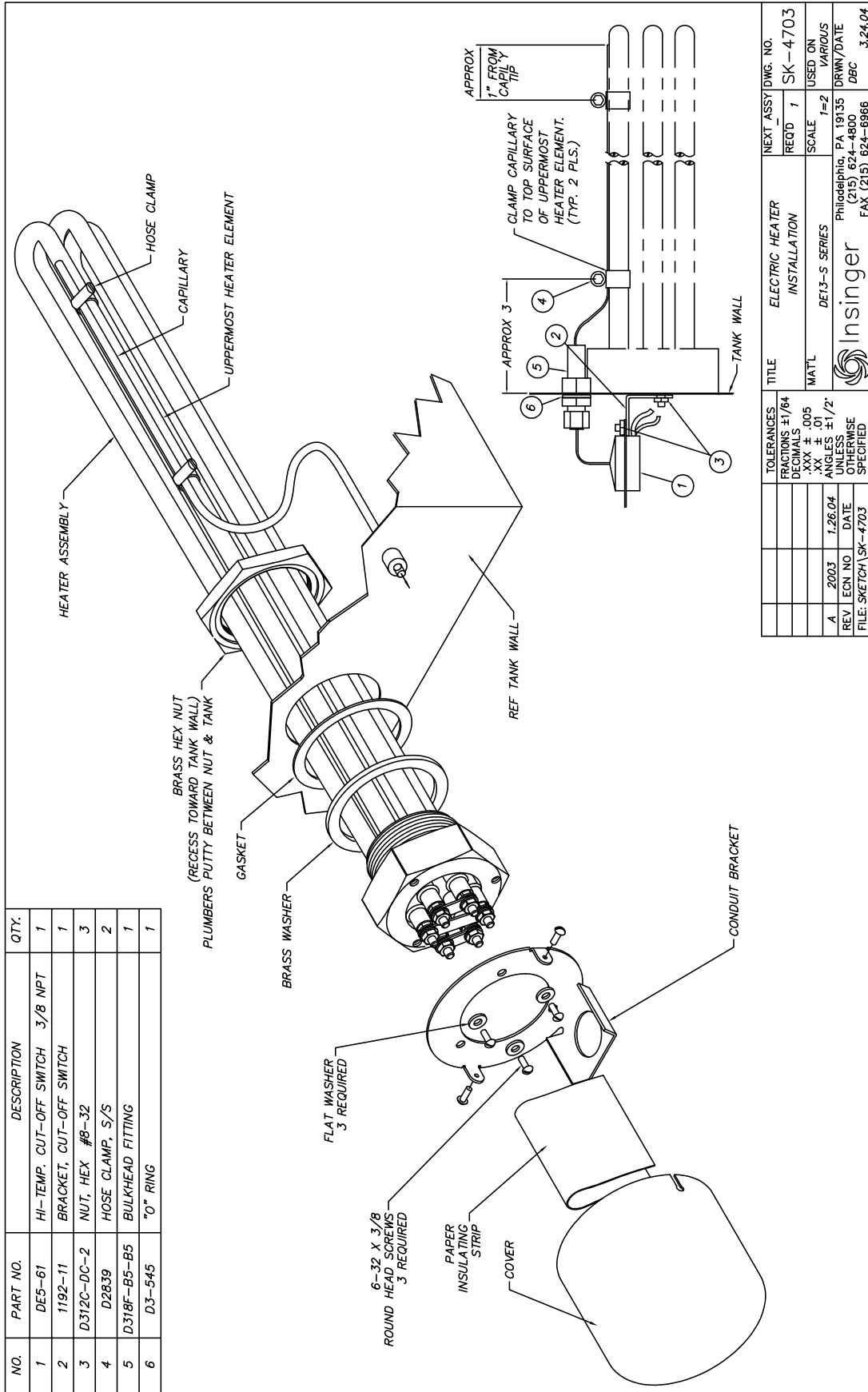
**SK-4703 : Electric Heater Installation**

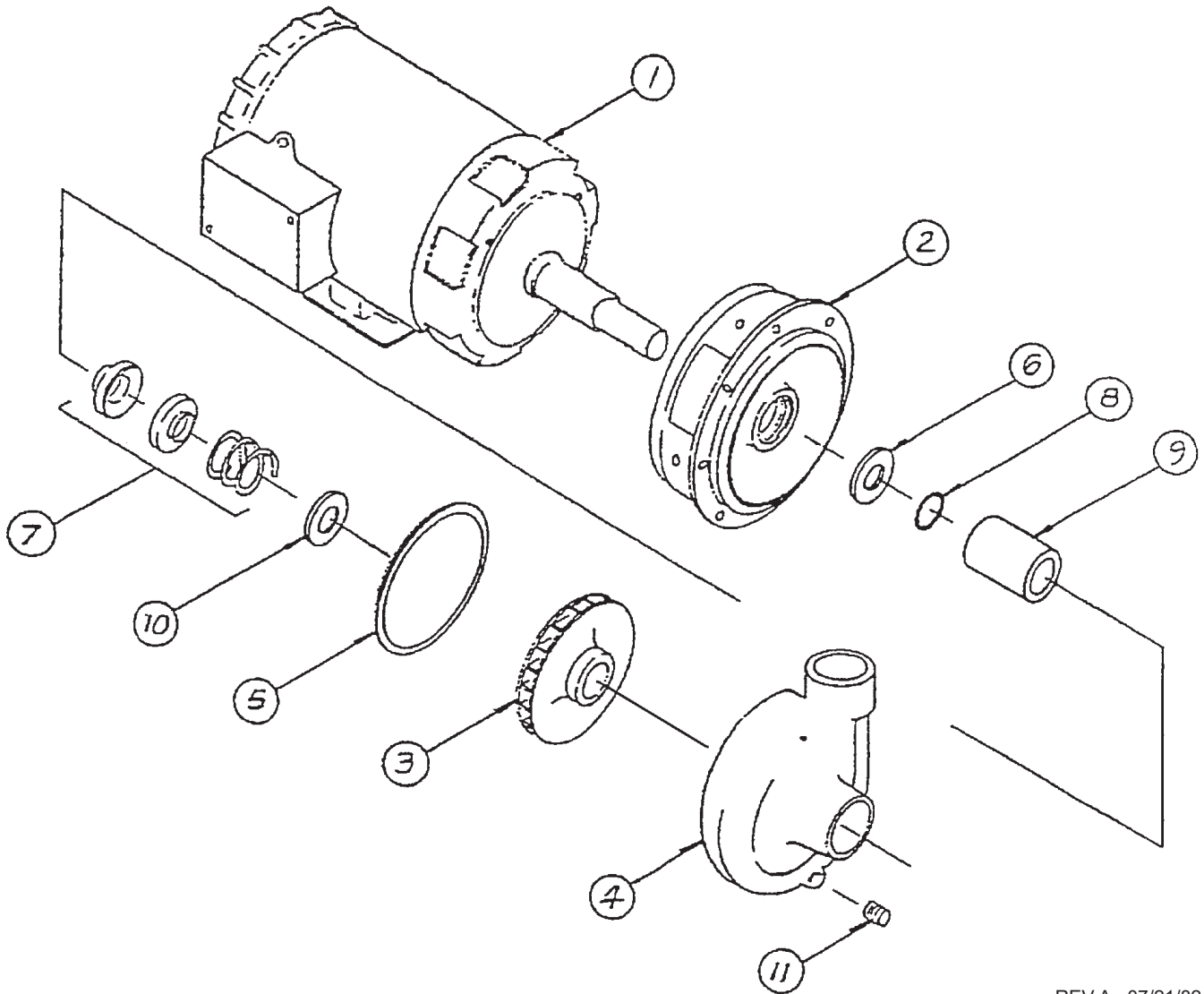
**SK-2525 : 5 HP Pump Motor Assembly**

REV A - 07/21/82

ITEM	PART NO.	DESCRIPTION	QTY
1		Motor 5 HP	1
2	D-439	Adapter	1
3	D-440	Impeller	1
4	D-441	Casing	1
5	D2-566	Gasket, Casing	1
6	D2-568	Flinger, Shaft	1
7	D-2494	Seal Assembly	1
8	D2-567	O-Ring, Shaft	1
9	D3-818	Sleeve, Shaft	1
10	D3-819	Retainer, Seal Spring	1
11		Drain Plug - 1/4 IPS	1

**TROUBLESHOOTING**

<b>TECHNICAL ISSUES</b>	<b>POSSIBLE CAUSES</b>	<b>SOLUTIONS</b>
<b>Machine will not operate</b>	<ol style="list-style-type: none"> <li>1. No power</li> <li>2. Blown fuse or tripped breaker</li> <li>3. Motor overloads tripped</li> </ol>	<ol style="list-style-type: none"> <li>1. Check power supply</li> <li>2. Replace fuse; reset breaker</li> <li>3. Reset overload</li> </ol>
<b>Tank will not hold water</b>	<ol style="list-style-type: none"> <li>1. Drain not closed</li> <li>2. Drain overflow not seated or installed</li> <li>3. Pump petcock opened</li> <li>4. Overflow v-seal dirty/worn</li> </ol>	<ol style="list-style-type: none"> <li>1. Close drain</li> <li>2. Reseat or install drain overflow</li> <li>3. Close pump petcock</li> <li>4. Clean/replace v-seal</li> </ol>
<b>Tank fills beyond overflow</b>	<ol style="list-style-type: none"> <li>1. Obstruction in overflow tube or drain line</li> </ol>	<ol style="list-style-type: none"> <li>1. Remove obstruction</li> </ol>
<b>Water leaks around door</b>	<ol style="list-style-type: none"> <li>1. Doors not seating</li> <li>2. Clogged spray pipe</li> </ol>	<ol style="list-style-type: none"> <li>1. Reseat doors</li> <li>2. Clean spray pipe with brush</li> </ol>
<b>Weak or ineffective spray</b>	<ol style="list-style-type: none"> <li>1. Clogged spray pipe</li> <li>2. Manifolds not installed properly</li> <li>3. Obstruction in pump</li> <li>4. Pump rotation reversed</li> <li>5. Suction strainer clogged</li> </ol>	<ol style="list-style-type: none"> <li>1. Clean spray pipe with brush pipe</li> <li>2. Ensure proper placement of upper and lower pipes</li> <li>3. Clear obstruction through pump inspection plate</li> <li>4. Arrow on pump housing indicates direction, correct electrically</li> <li>5. Clean suction strainer</li> </ol>
<b>Weak or ineffective final rinse spray</b>	<ol style="list-style-type: none"> <li>1. Lime deposits in spray nozzles</li> <li>2. Low water pressure</li> <li>3. Clogged line strainer</li> <li>4. Closed water supply valve</li> </ol>	<ol style="list-style-type: none"> <li>1. Clean or replace nozzles</li> <li>2. Adjust to 20PSI</li> <li>3. Remove line strainer and clean</li> <li>4. Open ball valve</li> </ol>
<b>Water hammer</b>	<ol style="list-style-type: none"> <li>1. Excessive water line pressure</li> </ol>	<ol style="list-style-type: none"> <li>1. Install water hammer valve</li> </ol>
<b>Machine vibrates or is noisy</b>	<ol style="list-style-type: none"> <li>1. Pump rotation reversed</li> <li>2. Pump bearings worn</li> </ol>	<ol style="list-style-type: none"> <li>1. Arrow on pump housing indicates direction, correct electrically</li> <li>2. Replace pump bearings</li> </ol>
<b>Final rinse will not shut off</b>	<ol style="list-style-type: none"> <li>1. Final rinse solenoid valve clogged</li> <li>2. Diaphragm worn</li> <li>3. Solenoid valve still powered-up</li> </ol>	<ol style="list-style-type: none"> <li>1. Disassemble valve and clean internal parts of scale or replace</li> <li>2. Replace with solenoid valve repair kit</li> <li>3. Check final rinse actuating circuit for proper operation</li> </ol>

**TROUBLESHOOTING**

TECHNICAL ISSUES	POSSIBLE CAUSES	SOLUTIONS
<b>Tank not filling/tank heat coming on with no water in tank</b>	<ol style="list-style-type: none"> <li>1. Level float dirty</li> <li>2. Level control system not working</li> </ol>	<ol style="list-style-type: none"> <li>1. Clean level float</li> <li>2. Troubleshoot level control circuit</li> </ol>
<b>Tank temperature too low/high</b>	<ol style="list-style-type: none"> <li>1. Thermostat not adjusted</li> <li>2. Heat circuitry not working</li> <li>3. Electric heat - power turned off</li> <li>4. Electric heat - immersion heaters limed</li> <li>5. Steam heat - steam turned off</li> <li>6. Steam heat - not enough steam</li> <li>7. Steam heat - condensate traps clogged</li> <li>8. Gas heat - gas turned off</li> <li>9. Gas heat - pilot not lit (if provided)</li> </ol>	<ol style="list-style-type: none"> <li>1. Adjust thermostat</li> <li>2. Troubleshoot circuitry</li> <li>3. Check circuit breakers</li> <li>4. De-lime machine</li> <li>5. Turn steam on</li> <li>6. Adjust steam pressure per machine specs</li> <li>7. Clean or replace condensate traps</li> <li>8. Turn on gas</li> <li>9. Re-light pilot</li> </ol>

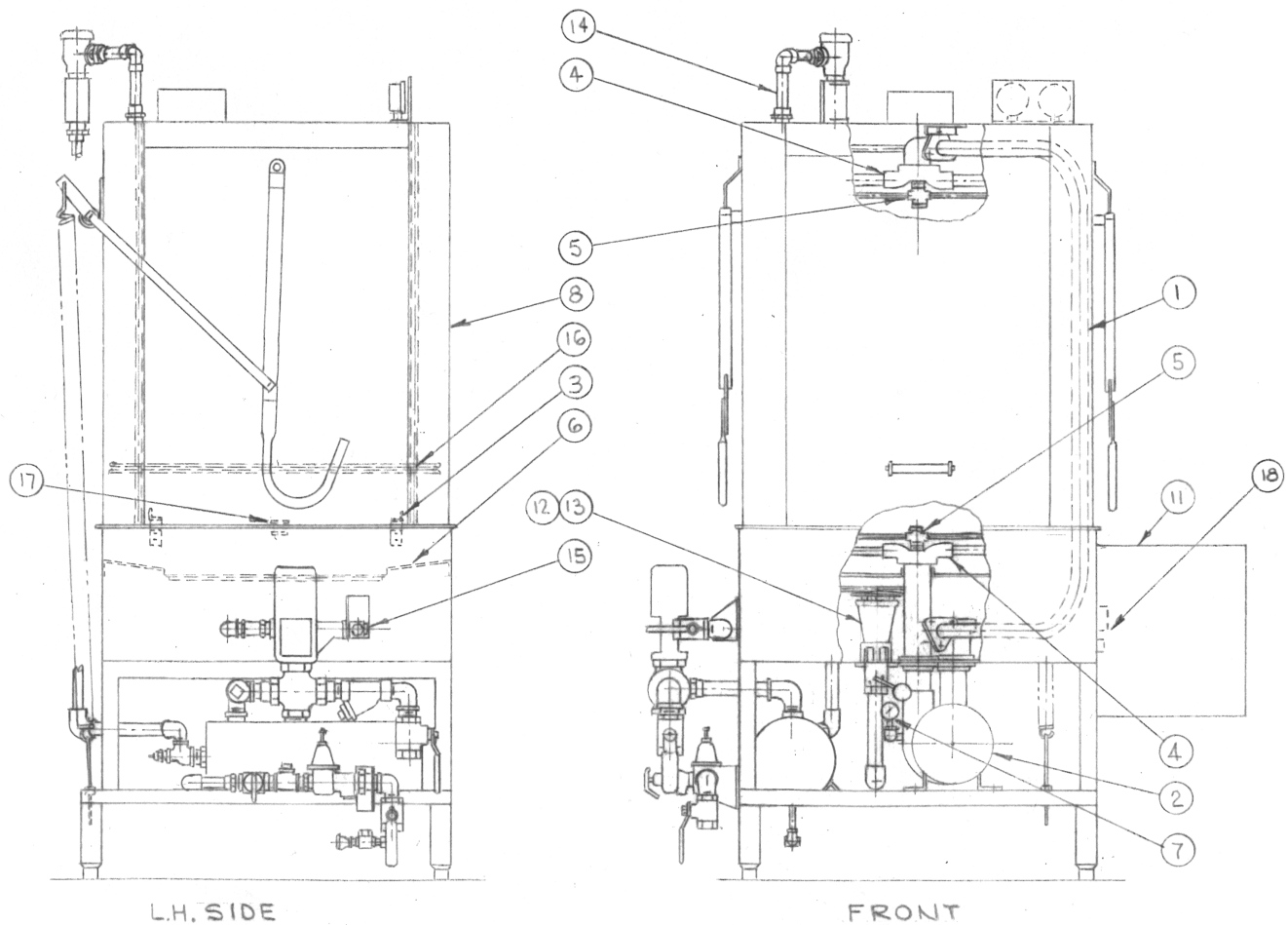

ITEM	PART NO.	DESCRIPTION	QTY
1	1172-11	Discharge Line Assembly	1
2	1172-9	Pump & Motor Installation	1
3	979-37	Track & Track Bracket Location	1
4	1172-17	Spray Nozzle Assembly - Wash	2
5	1172-20	Spray Nozzle Assembly - Rinse	2
6	1172-3	Scrap Screen Arrangement	1
7	1172-42	Pressure Gauge Installation	1
8	1172-33	Shell Assembly	1
11	1173-10	Control Box Location	1
12	954-1	Drain Assembly	1
13	925-52	Drain Handle	1
14	1172-84	Final Rinse Piping w/ Steam Booster	1
	1172-27	Final Rinse Piping w/ Electric Booster	1
15	1172-47	Steam Piping (Injector)	1
	1172-49	Steam Coil - Solenoid Operated	1
16	562-137	Grid Installation Assembly	1
17	D2626	Proximity Switch Location	1
18	1172-51	Electric Heater, Liquid Level Float & Diode Junction Locations	1

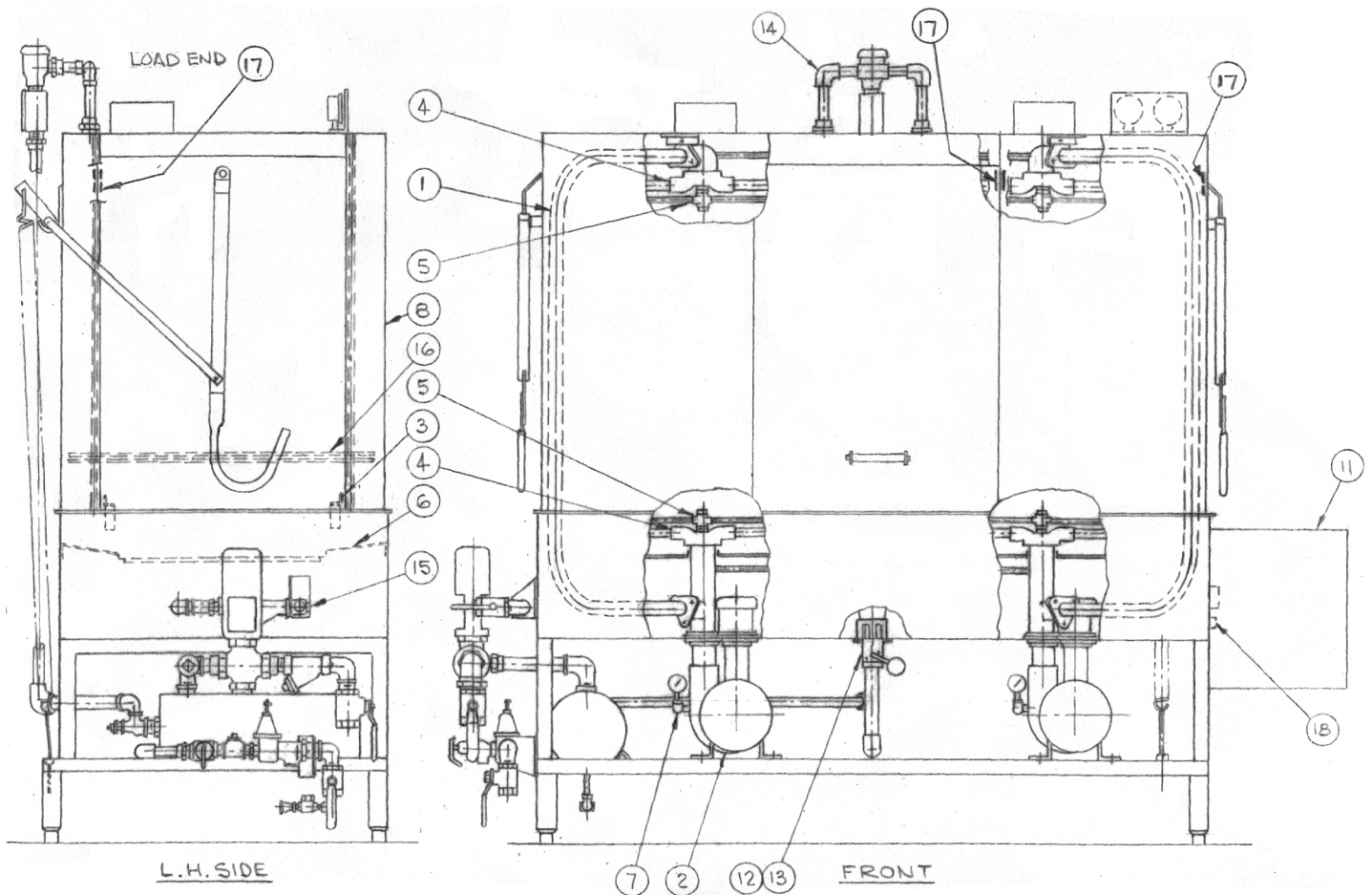

ITEM	PART NO.	DESCRIPTION	QTY
1	1173-11	Discharge Line Assembly	1
2	1173-9	Pump & Motor Installation	1
3	930-15	Track & Track Bracket Location	1
4	1172-17	Spray Nozzle Assembly - Wash	4
5	1172-20	Spray Nozzle Assembly - Rinse	4
6	1173-3	Scrap Screen Arrangement	1
7	1172-42	Pressure Gauge Installation	2
8	1173-12	Shell Assembly	1
11	1173-10	Control Box Location	1
12	954-1	Drain Assembly	1
13	925-52	Drain Handle	1
14	1173-37	Final Rinse Piping w/ Steam Booster	1
	1173-14	Final Rinse Piping w/ Electric Booster	1
15	1172-47	Steam Piping (Injector)	1
	1172-49	Steam Coil - Solenoid Operated	1
16	593-41	Grid Installation Assembly	1
17	D2626	Proximity Switch Location	2
18	1172-51	Electric Heater, Liquid Level Float & Diode Junction Locations	1

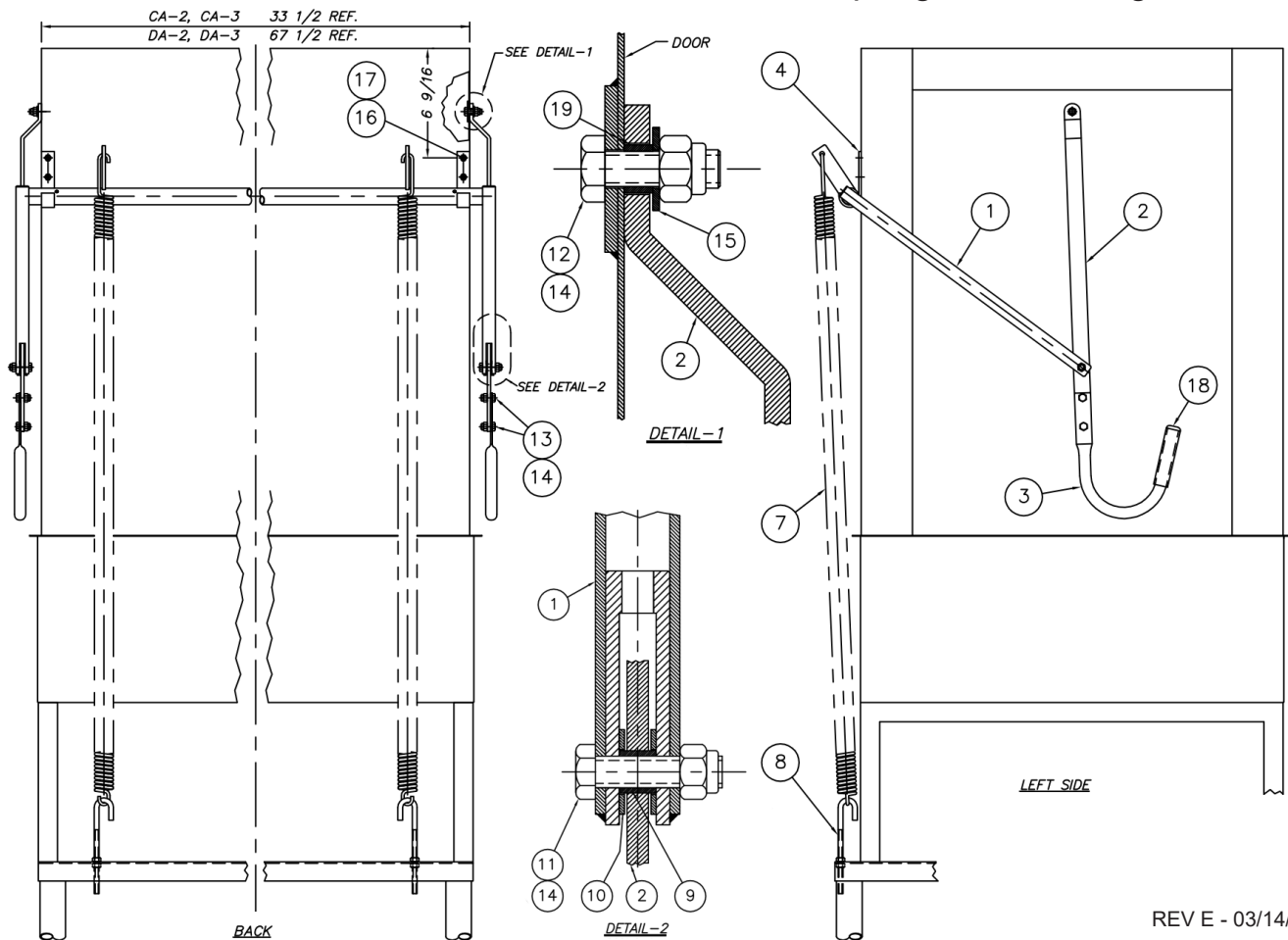

**925-40 : Spring Counterweight Assembly**

REV E - 03/14/01

ITEM	PART NO.	DESCRIPTION	QTY
1	925-41 930-19	Door Arm Weldment, CA Door Arm Weldment, DA	1
2	562-33	Door Arm	2
3	562-34	Door Handle	2
4	925-42	Bracket Door Arm	2
7	SK-2290A	Spring	2
8	925-44	Spring Extension Rod	2
9	562-35-1	Lower Spacer x 7/16" LG	2
10	562-71	Washer	4
11	D309C-JC-12A	Hex Head Screw S/S 3/8 x 1 1/2" Lg.	2
12	D309C-JC-9A	Hex Head Screw S/S 3/8 x 1 1/8" Lg.	2
13	D309C-JC-7A	Hex Head Screw S/S 3/8 x 7/8" Lg.	4
14	D312C-JC-5	Locknut (Seal) S/S 3/8-16	8
15	D313C-J1	3/8 Flat Washer S/S	2
16	D309C-GC-6E	Seal Head Screw S/S 1/4-20 x 3/4" Lg.	4
17	D312C-GC-5	Locknut (Seal) S/S 1/4-20	4
18	D2245	Plastic Handle Cover	2
19	562-35-2	Upper Spacer 5/16" Lg.	2

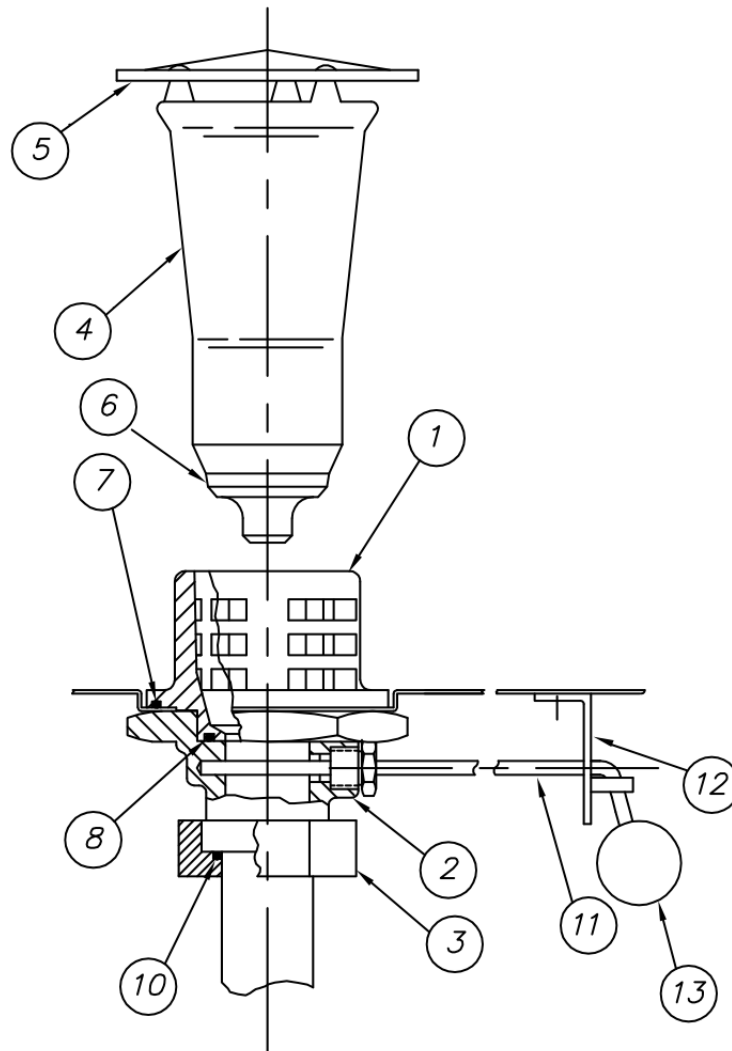
**SK-2519A : Drain Assembly**

REV A - 08/30/82

ITEM	PART NO.	DESCRIPTION	QTY
	925-50	Drain Assembly	-
1	954-50A	Upper Body	1
2	954-50B	Lower Body	1
3	954-50C	Nut	1
4	954-50D	Overflow Tube	1
5	D-193	Overflow Tube Skimmer Cap	1
6	D2-557	"V" Seal Drain Seat	1
7	D2-548	O-Ring	1
8	D2-549	O-Ring	1
9	D-305	Drain Jam Nut	1
10	D2-550	O-Ring	1
11	954-55	Drain Handle Assembly	1
12	954-8	Bracket	1
13	D-2407	Ball	1

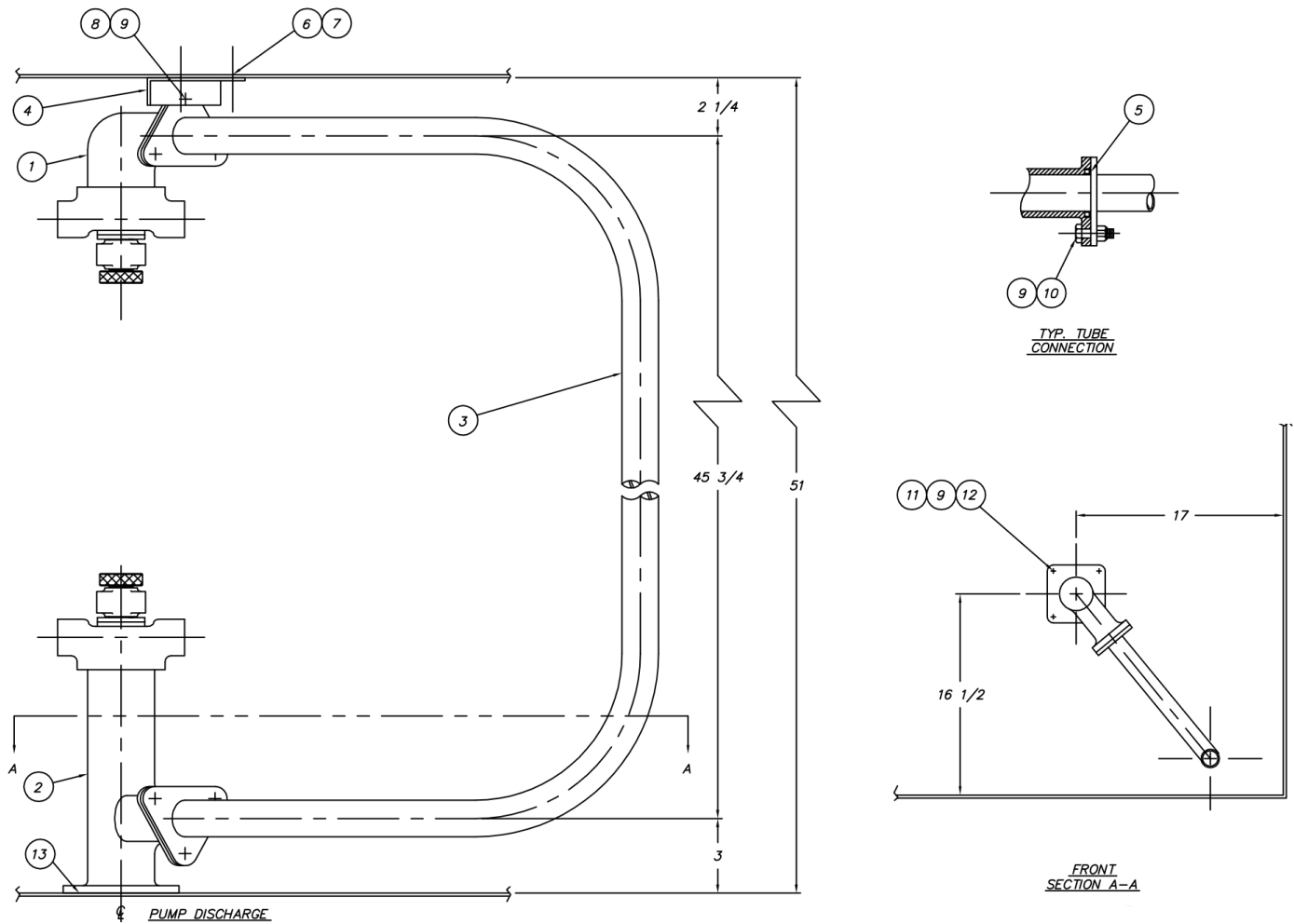
**1172-11 : CA-3 Discharge Line Assembly**

REV A - 07/15/94

ITEM	PART NO.	DESCRIPTION	QTY
1	1172-57	Upper Manifold Assembly	1
2	1172-56	Lower Manifold Assembly	1
3	1172-12	Discharge Line Tube Assembly	1
4	1172-50	Flange Support	1
5	D2620	Cupseal - Parker 8406-0150-4180	2
6	D309C-HC-5A	Screw Hex Head 5/16-18 x 5/8" S/S	2
7	D312C-HC-5	Locknut 5/16-18	2
8	D309C-JC-10A	Screw Hex Head 3/8-16 x 1 1/4" S/S	1
9	D312C-JC-5	Locknut 3/8-16	10
10	D309C-JC-9A	Screw Hex Head 3/8-16 x 1 1/8" S/S	5
11	D309C-JC-11A	Screw Hex Head 3/8-16 x 1 3/8" S/S	4
12	D313A-J1	Washer 3/8", Copper	4
13	-	Plumber's Putty	AR

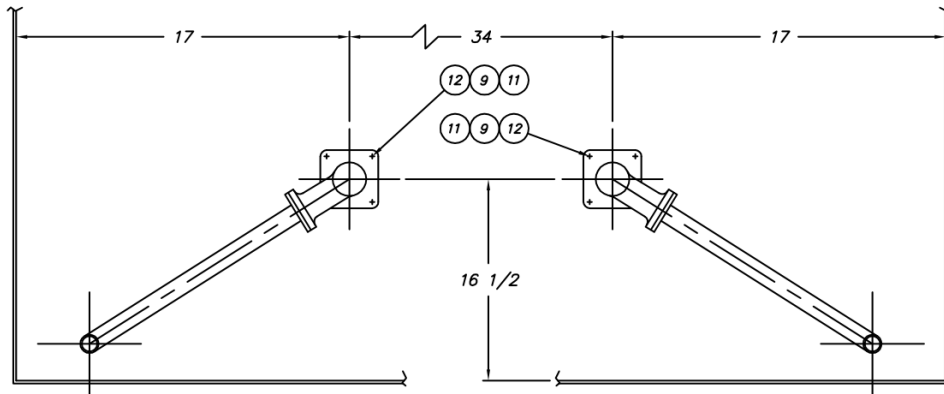
**1173-11 : DA-3 Discharge Line Assembly**

FRONT  
SECTION A-A

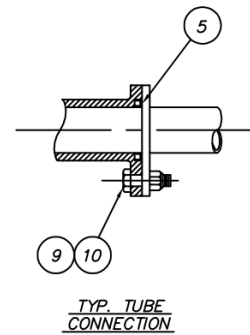
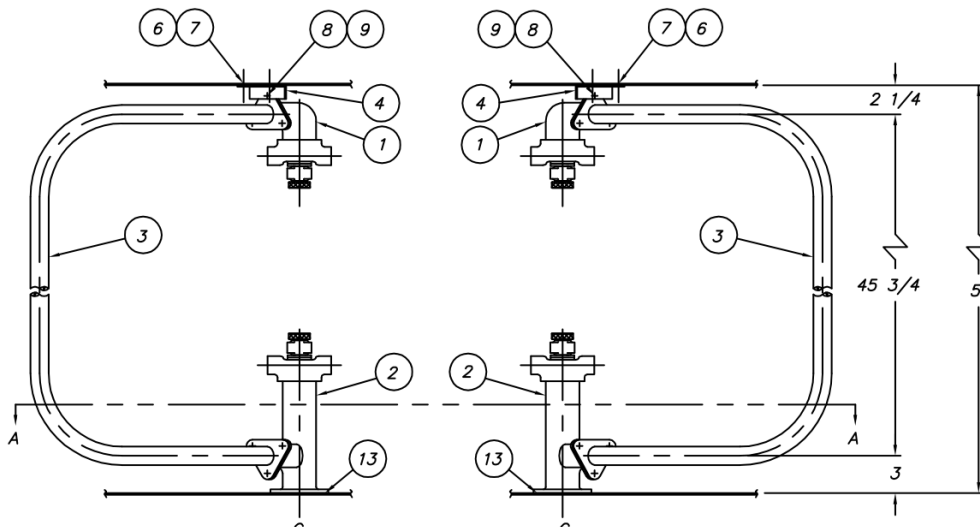

REV A - 07/18/94

ITEM	PART NO.	DESCRIPTION	QTY
1	1172-57	Upper Manifold Assembly	2
2	1172-56	Lower Manifold Assembly	2
3	1172-12	Discharge Line Tube Assembly	2
4	1172-50	Flange Support	2
5	D2620	Cupseal - Parker 8406-0150-4180	4
6	D309C-HC-5A	Screw Hex Head 5/16-18 x 5/8" S/S	4
7	D312C-HC-5	Locknut 5/16-18	4
8	D309C-JC-10A	Screw Hex Head 3/8-16 x 1 1/4" S/S	2
9	D312C-JC-5	Locknut 3/8-16	20
10	D309C-JC-9A	Screw Hex Head 3/8-16 x 1 1/8" S/S	10
11	D309C-JC-11A	Screw Hex Head 3/8-16 x 1 3/8" S/S	8
12	D313A-J1	Washer 3/8", Copper	8
13	-	Plumber's Putty	AR

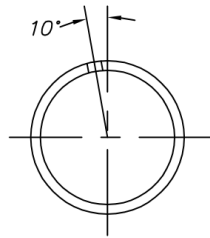
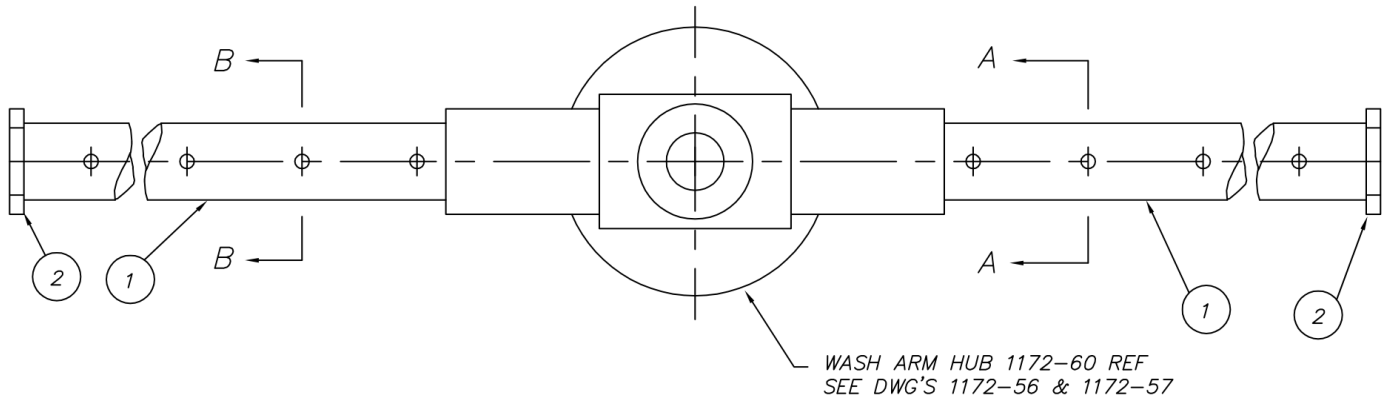
**1172-17 : Wash Spray Nozzle Assembly**

SECTION B-B

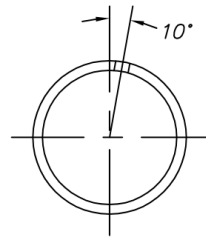

SECTION A-A

REV C - 12/23/92

ITEM	PART NO.	DESCRIPTION	QTY
1	979-33	Spray Pipe	2
2	D2-554-3	Plug 7/8-9 UNC-2A	2

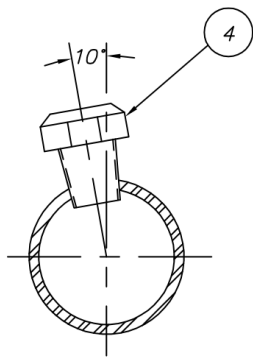
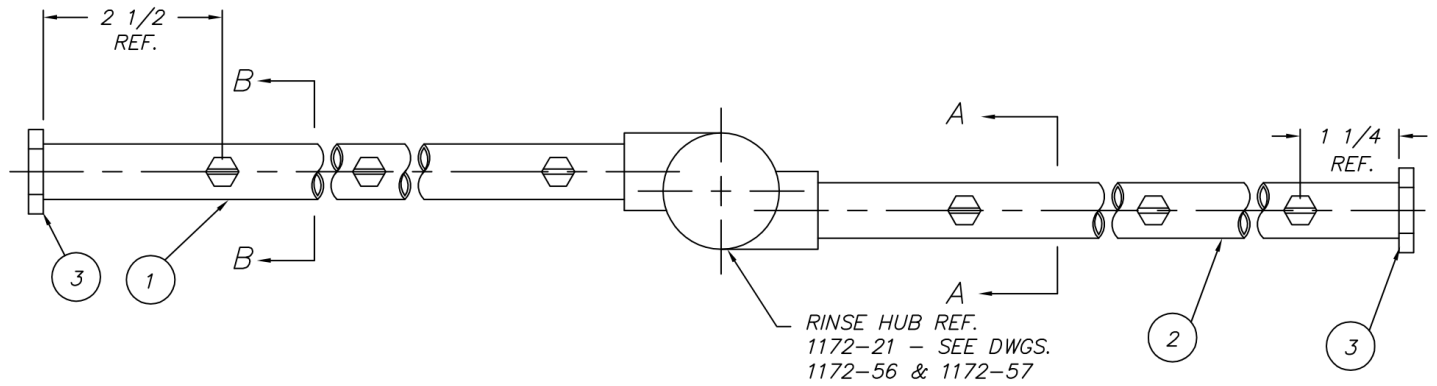
**1172-20 : Rinse Spray Nozzle Assembly**

SECTION B-B

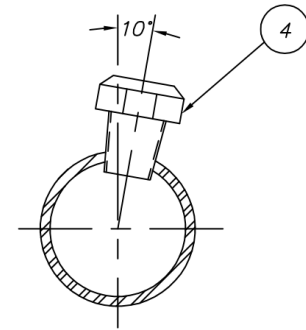

SECTION A-A

REV C - 01/21/15

ITEM	PART NO.	DESCRIPTION	QTY
1	1172-34	Spray Pipe	1
2	1172-35	Spray Pipe	1
3	D2-554-1	Plug 9/16-12 UNC-2A	2
4	D2828	Nozzle H1/8U-5015	6

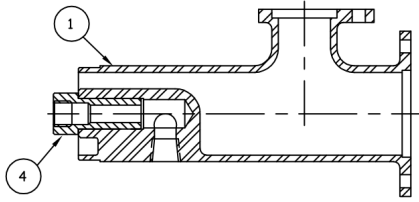

SUBASSEMBLY 1172-56A  
FOR SERVICE

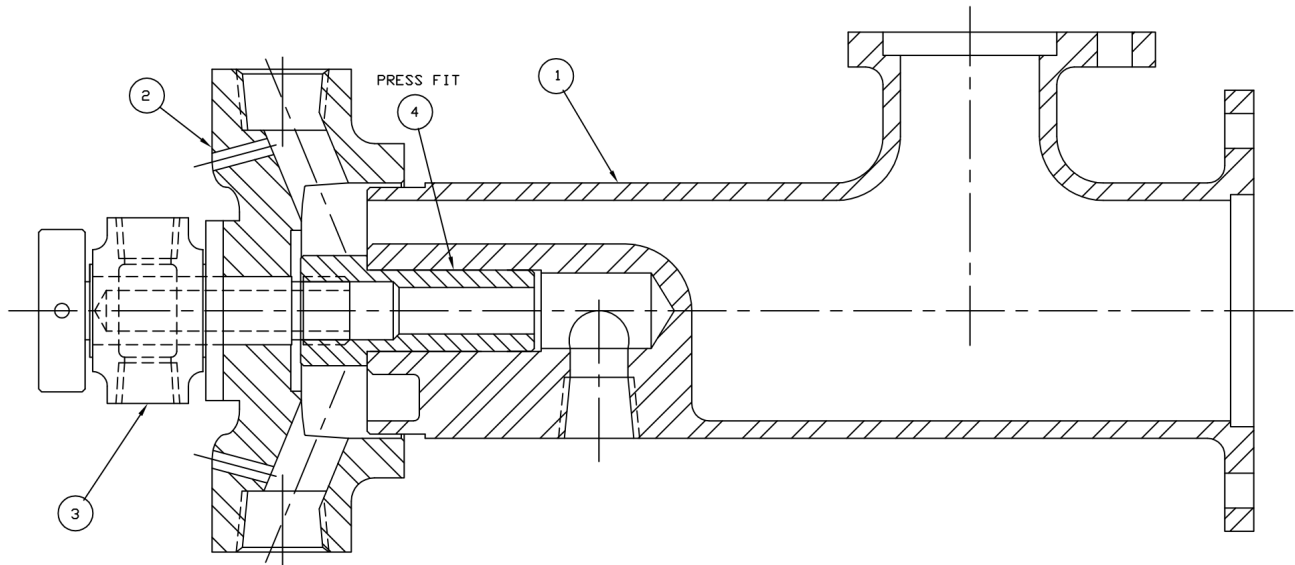

REV E - 06/05/98

ITEM	PART NO.	DESCRIPTION	QTY
1	1172-58	Lower Discharge Manifold	1
2	1172-70	Wash Arm Hub with Bearing	1
	1172-69	Bearing (without Hub)	
3	1172-73	Rinse Assembly	1
4	1172-62	Wash Arm Shaft	1

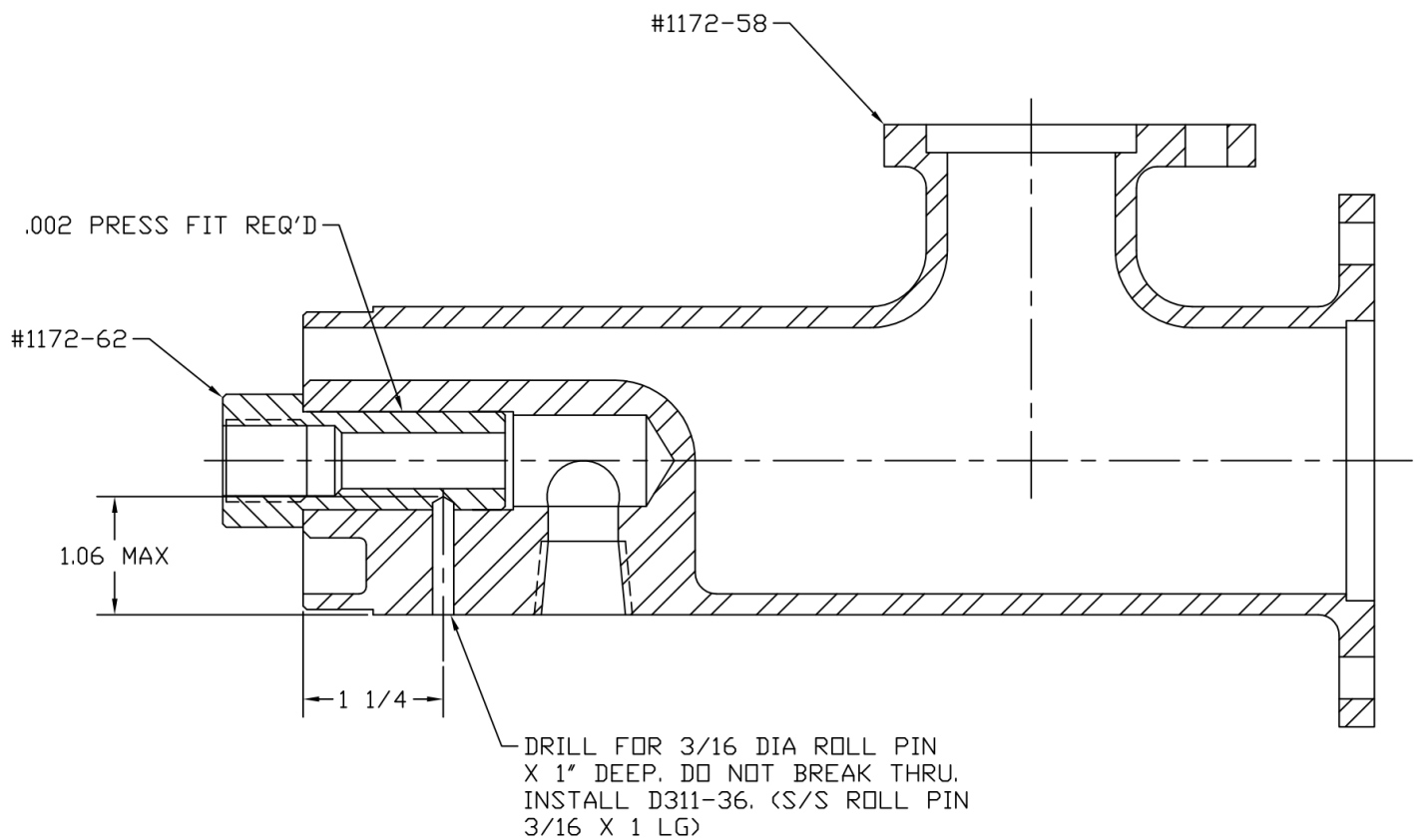
**1172-56A : Lower Manifold & Shaft Sub-Assembly**

REV A - 02/15/13

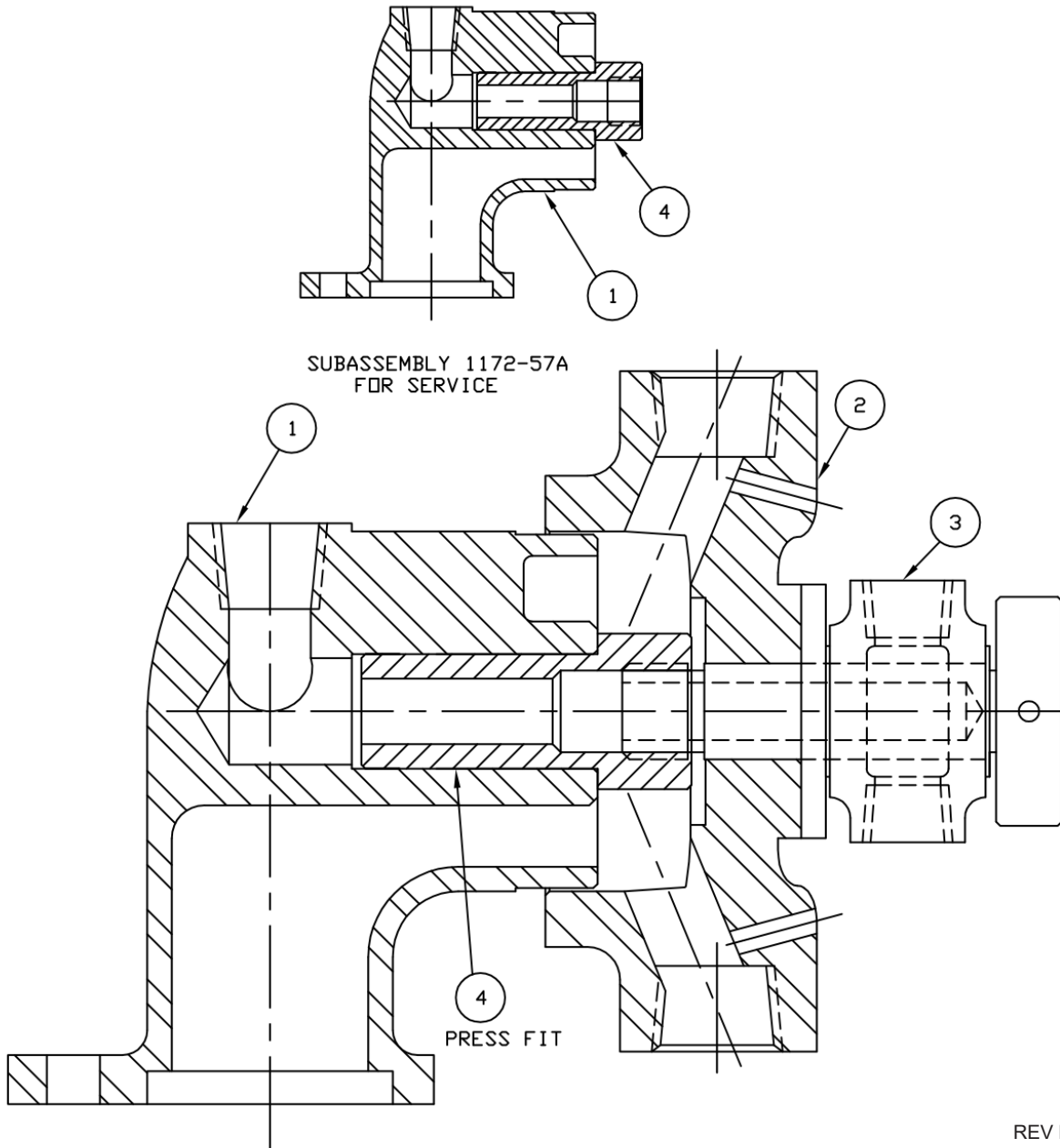

**1172-57 : Lower Manifold Assembly**

ITEM	PART NO.	DESCRIPTION	QTY
1	1172-59	Upper Discharge Manifold	1
2	1172-70	Wash Arm Hub with Bearing	1
	1172-69	Bearing (without Hub)	
3	1172-73	Rinse Assembly	1
4	1172-62	Wash Arm Shaft	1

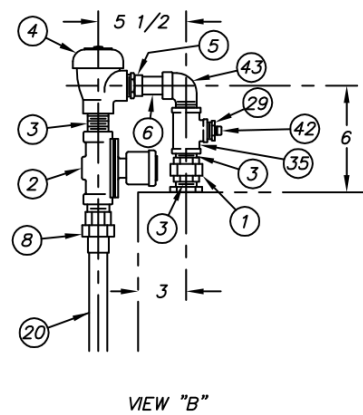
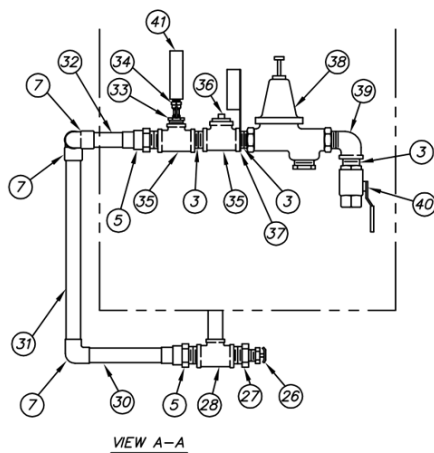
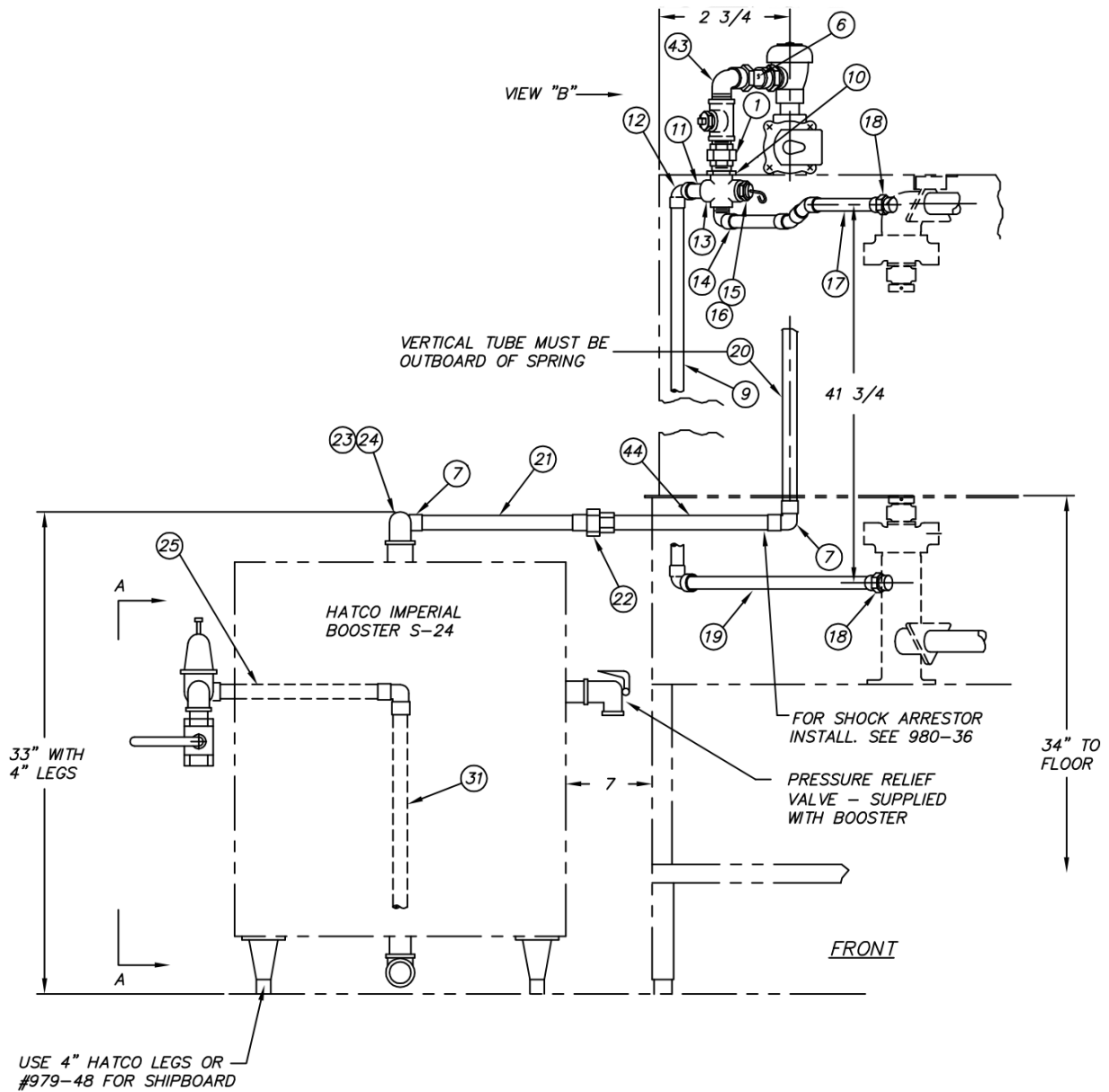
**1172-27 : CA-3 Final Rinse Piping with Electric Booster**

REV K - 03/09/18

**1172-27 : CA-3 Final Rinse Piping with Electric Booster**

#	PART NO.	SIZE	DESCRIPTION	QTY
1	D318F-F1-F1	-	Union 1" FIPS x 1" FIPS	1
** 2	D2944	-	Solenoid 1" IPS	1
3	D314F-FC-00	-	Nipple Close 1" IPS	6
4	D-2249	-	Vacuum Breaker 1" IPS	1
5	D317A-F3-F2	-	Adapter 1" C x 1" MIPS	3
6	D207A-B8-16	-	Copper Tubing 1" CTS x 4" Lg.	1
7	D316A-F3-F3	-	90° Elbow 1" C	5
8	D318A-F3-F2	-	Union 1" C x 1" MIPS	1
9	979-41	A	S/S Vertical Rinse Pipe Assembly	1
10	D326A-F1	-	Locknut 1" IPS	1
* 11	D314J-ES-16	-	Nipple 3/4" IPS x 2" Lg.	1
* 12	D316E-E3-E1	-	90° Elbow 3/4" C x 3/4" FIPS	1
13	593-24	A	Cross 1" x 3/4" x 3/4" x 1/2" IPS	1
* 14	D316E-E3-E2	-	90° Elbow 3/4" C x 3/4" MIPS	1
15	D2390SP	-	Split Jam Nut	1
16	D2390SP-1	-	Brass Union	1
17	979-42	A	S/S Upper Rinse Pipe	1
* 18	D318E-E3-E2	-	Union 3/4" C x 3/4" MIPS	2
19	D207C-L7-73	-	S/S Tubing 7/8" OD x 18 1/4" Lg.	1
20	D207A-B8-156	-	Copper Tubing 1" CTS x 39" Lg.	1
21	D207A-B8-50	-	Copper Tubing 1" CTS x 12 3/8" Lg	1
22	D318A-F3-F3	-	Union 1" C	1

#	PART NO.	SIZE	DESCRIPTION	QTY
23	D316A-F3-F1	-	90° Elbow 1" C x 1" FIPS	1
24	D207A-B8-66	-	Copper Tubing 1" CTS x 16 1/2" Lg.	1
25	D207A-B8-48	-	Copper Tubing 1" CTS x 12" Lg.	1
26	D329-5	-	Drain Cock 1/4" IPS	1
27	D322F-F2-B1	-	Reducer 1" MIPS x 1/4" FIPS	1
28	D320F-F1F1F1	-	Tee 1" IPS	1
29	D322F-E2-41	-	Hex Reducer 3/4" MIPS x 1/8" FIPS	1
30	D207A-B8-38	-	Copper Tubing 1" CTS x 9 1/2" Lg.	1
31	D207A-B8-64	-	Copper Tubing 1" CTS x 16" Lg.	1
32	D207A-B8-18	-	Copper Tubing 1" CTS x 4 1/2" Lg.	1
33	D322F-E2-B1	-	Reducer 3/4" MIPS x 1/4" FIPS	1
34	D-2497	-	Petcock 1/4" IPS	1
35	D320F-F1F1E1	-	Tee 1" x 1" x 3/4" IPS	3
36	D328F-E2A	-	Pipe Plug 3/4" IPS	1
37	925-48	A	Support Bracket	1
38	D-2266	-	Pressure Regulator & Strainer 1" IPS	1
39	D316F-F1-F2	-	90° Street Elbow 1" FIPS x 1" MIPS	1
40	D-2379	-	Ball Valve 1" IPS	1
41	SK-1433	-	Pressure Gauge 1/4" IPS	1
42	D328F-A2A	-	Pipe Plug 1/8" IPS	1
43	D316A-F3-F2	-	90° Street Elbow 1" C X 1" MIPS	1
44	D207A-B8-22	-	Copper Tubing 1" CTS x 5 3/8" Lg.	1

\* Chrome Plated Brass or Bronze

\*\* 24V (unless otherwise noted)

**NOTE:** Pressure Regulator/Strainer (Item 38) to be furnished by others unless specified on production card - use D-2448 "Y" Strainer as standard.

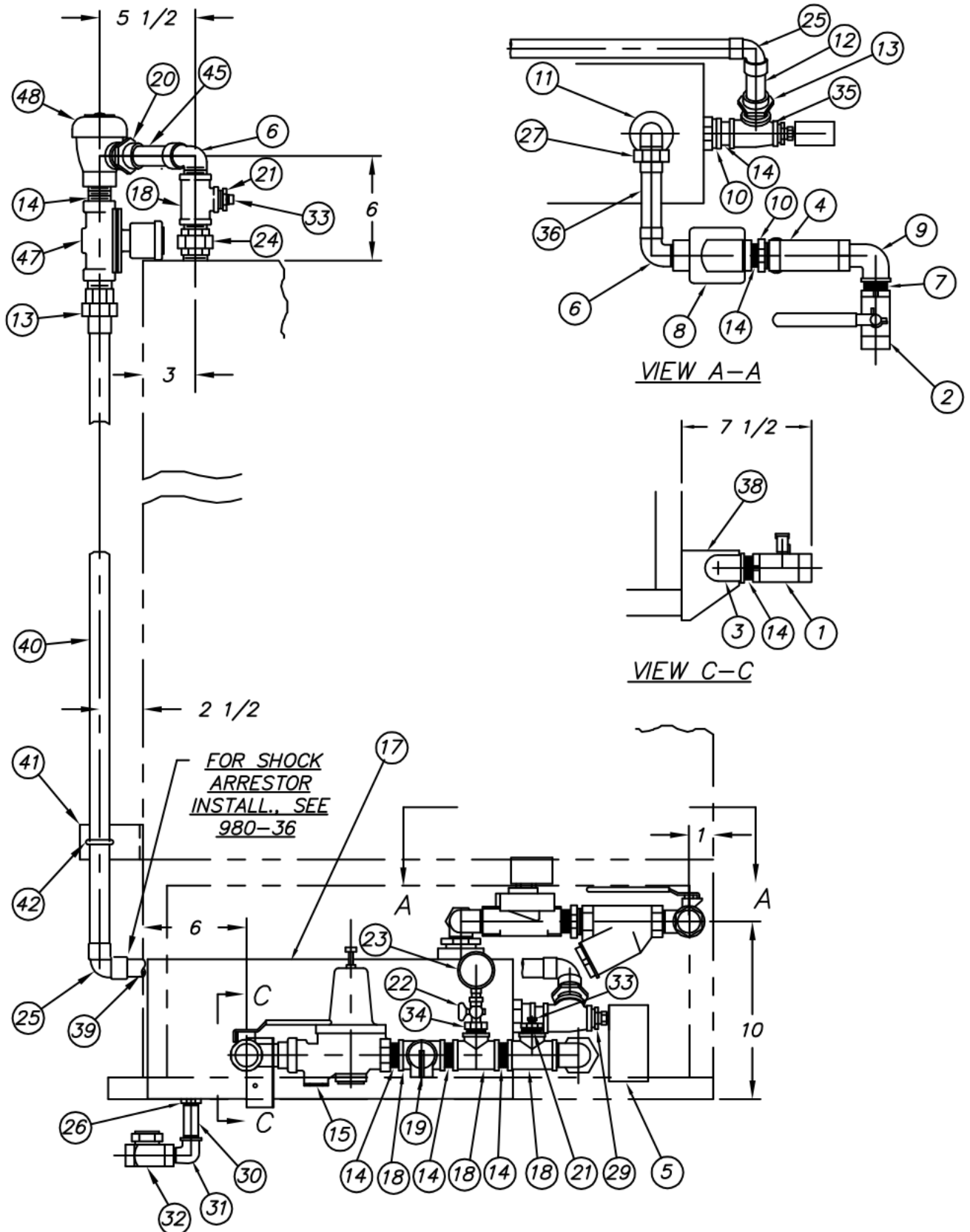
**1172-84 : CA-3 Final Rinse Piping with I-3 Booster**

REV D - 03/09/18

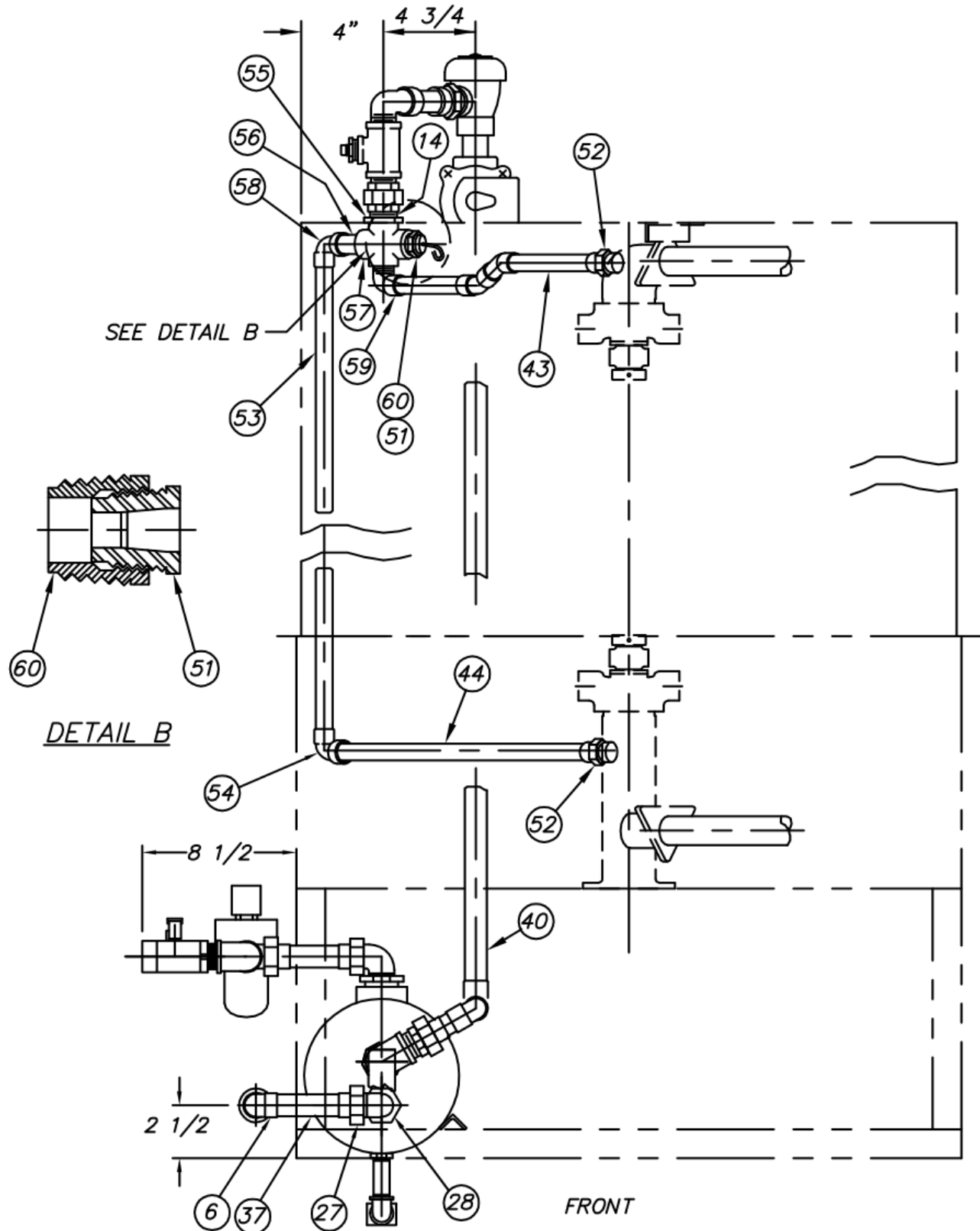
**1172-84 : CA-3 Final Rinse Piping with I-3 Booster**

REV D - 03/09/18

**1172-84 : CA-3 Final Rinse Piping with I-3 Booster**

ITEM	PART NO.	DESCRIPTION	QTY
1	D2379	Ball Valve 1" IPS	1
2	D2363	Ball Valve 1 1/4" IPS	1
3	D316F-F1-F2	90° Street Elbow 1" FIPS x 1" MIPS	1
4	D2447	"Y" Strainer 1 1/4" IPS	1
5	D2396	Steam Temperature Regulator 3/8" IPS	1
6	D316F-F3-F2	90° Elbow 1" C x 1" MIPS	3
7	D314F-GC-00	Close Nipple 1 1/4" IPS	1
8	D2947	Solenoid Valve 1" IPS	1
9	D316F-G1-G2	90° Street Elbow 1 1/4" FIPS x 1 1/4" MIPS	1
10	D322F-G2-F1	Hex Reducer 1 1/4" MIPS x 1" FIPS	1
11	D322F-H2-F1	Hex Reducer 1 1/2" MIPS x 1" FIPS	1
12	D207A-B8-10	Copper Tubing 1" CTS x 2 1/2" Lg.	1
13	D318A-F3-F2	Union 1" C x 1" MIPS	2
14	D314F-FC-00	Close Nipple 1" IPS	10
15	D2266	Pressure Regulator & Strainer 1" IPS	1
16	-	-	-
17	D2443	I-3 Booster (21")	1
18	D320F-F1F1E1	Tee 1" FIPS x 1" FIPS x 3/4" FIPS	4
19	D2507	Pressure Relief Valve 3/4" IPS	1
20	D317A-F3-F2	Adapter 1" C x 1" MIPS	1
21	D322F-E2-A1	Hex Reducer 3/4" MIPS x 1/8 FIPS	2
22	D2497	Petcock 1/4" IPS	1
23	SK-1443	Pressure Gauge 1/4" IPS	1
24	D318F-F1-F1	Street Union 1" FIPS x 1" FIPS	1
25	D316A-F3-F3	90° Elbow 1" C	2
26	D322F-E2-D1	Hex Reducer 3/4" MIPS x 1/2" FIPS	1
27	D319A-F3-F2	90° Union Elbow 1" C x 1" MIPS	2
28	D322F-G2-F1	Hex Reducer 1 1/4" MIPS x 1" FIPS	2
29	D322F-E2-C1	Hex Reducer 3/4" MIPS x 3/8" FIPS	1
30	D314F-DS-24	Nipple 1/2" IPS x 3" Lg.	1
31	D316F-D1-D2	90° Street Elbow 1/2" FIPS x 1/2" MIPS	1

**NOTE:**

Pressure Regulator/Strainer (Item 15) to be furnished by others unless specified on production card - use D-2448 "Y" Strainer as standard.

**1172-84 : CA-3 Final Rinse Piping with I-3 Booster**

ITEM	PART NO.	DESCRIPTION	QTY
32	D2102A	Steam Trap 1/2" IPS	1
33	D328F-A2A	Pipe Plug 1/8"	2
34	D322F-E2-B1	Hex Reducer 3/4" MIPS x 1/4" FIPS	1
35	D320F-F1E1F1	Tee 1" FIPS x 3/4" FIPS 1" FIPS	1
36	D207A-B8-20	Copper Tubing 1" CTS x 5" Lg.	1
37	D207A-B8-18	Copper Tubing 1" CTS x 4 1/2" Lg.	1
38	925-48	Bracket	1
39	D207A-B8-103	Copper Tubing 1" CTS x 25 3/4" Lg.	1
40	D207A-B8-224	Copper Tubing 1" CTS x 56" Lg.	1
41	925-49	Bracket	1
42	D72A	Pipe Clamp	1
43	979-42	S/S Upper Rinse Pipe (Consists of ** items)	1
44	D207C-L7-73	S/S Tubing 7/8" OD x 18 1/4" Lg.	1
45	D207A-B8-10	Copper Tubing 1" CTS x 4" Lg.	1
46	-	-	-
47	D2944	Solenoid Valve 1" IPS	1
48	D2249	Vacuum Breaker 1" IPS	1
49	-	-	-
50	-	-	-
51	D2390SP	Split Jam Nut	1
* 52	D318E-E3-E2	Street Union 3/4" MIPS x 3/4" C	2
53	D207C-L7-168	S/S Tubing 7/8" OD x 42" Lg.	1
* 54	D316E-E3-E3	90° Elbow 3/4" C	1
55	D326F-F1	Lock Nut 1" IPS	1
56	D314C-ES-16	Nipple 3/4" IPS x 2" Lg. S/S	1
57	593-24	Cross 1" x 3/4" x 3/4" x 1/2" FIPS	1
* 58	D316E-E3-E1	90° Elbow 3/4" C x 3/4" FIPS	1
* 59	D316E-E3-E2	90° Elbow 3/4" C x 3/4" MIPS	1
60	D2390SP-1	Brass Union	1
* **	D315E-E3-E3	45° Elbow 3/4" C	1
* **	D315E-E3-E4	45° Street Elbow 3/4" C x 3/4" FTG	1

\* Nickel Plated Copper or Brass

**1173-14 : DA-3 Final Rinse Piping with Electric Booster**

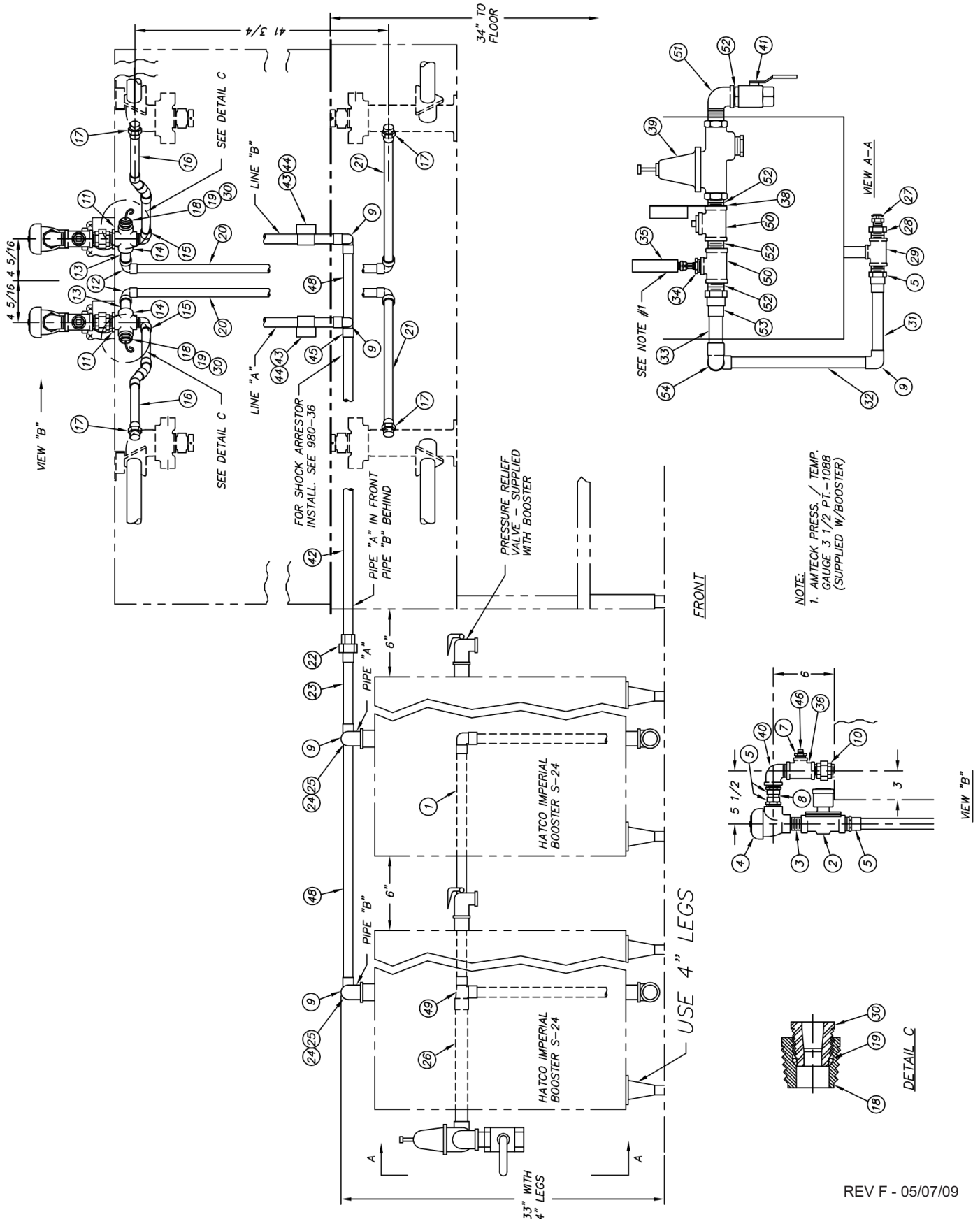

REV F - 05/07/09



**1173-14 : DA-3 Final Rinse Piping with Electric Booster**

ITEM	PART NO.	SIZE	DESCRIPTION	QTY	
	1	D207A-B8-80	-	Copper Tubing 1" CTS x 20" Lg.	1
**	2	D2607		Solenoid 1" IPS	2
	3	D314F-FC-00	-	Nipple Close 1" IPS	5
	4	D-2249	-	Vacuum Breaker 1" IPS	2
	5	D317A-F3-F2	-	Adapter 1" C x 1" MIPS	7
	6	D207A-B8-5	-	Copper Tubing 1" CTS x 1 1/4" Lg.	1
	7	D322F-E2-A1	-	Hex. Reducer 3/4" MIPS x 1/8" FIPS	2
	8	D207A-B8-12	-	Copper Tubing 1" CTS x 3" Lg.	2
	9	D316A-F3-F3	-	90° Elbow 1" C	7
	10	D318F-F1-F1	-	Street Union 1" FIPS x 1" FIPS	2
	11	D326F-F1	-	Locknut 1" IPS	2
*	12	D316E-E3-E1	-	90° Elbow 3/4" C x 3/4" FIPS	2
*	13	D314J-ES-16	-	Nipple 3/4" IPS x 2" Lg.	2
	14	593-24	A	Cross 1" x 3/4" x 3/4" 1/2" IPS	2
*	15	D316E-E3-E2	-	90° Elbow 3/4" C x 3/4" MIPS	2
	16	979-42	A	S/S Upper Rinse Pipe	2
*	17	D318E-E3-E2	-	Union 3/4" C x 3/4" MIPS	4
*	18	D2930SP-1	-	Brass Union	2
	19	D3-545	-	O-Ring	2
	20	979-41	A	S/S Vertical Rinse Pipe Assembly	2
	21	D207C-C7-73	-	S/S Tubing 7/8" OD x 18 1/4" Lg.	2
	22	D318A-F3-F3	-	Union 1" C	2
	23	D207A-B8-50	-	Copper Tubing 1" CTS x 12 3/8" Lg.	2
	24	D316A-F3-F1	-	90° Elbow 1" C x 1" FIPS	2
	25	D207A-B8-51	-	Copper Tubing 1" CTS x 12 3/4" Lg.	2
	26	D207A-B10-48	-	Copper Tubing 1 1/4" CTS x 12" Lg.	1
	27	D329-5	-	Drain Cock 1/4" IPS	2

\* Chrome Plated Brass or Bronze

\*\* 24V (unless otherwise noted)

**1173-14 : DA-3 Final Rinse Piping with Electric Booster**

ITEM	PART NO.	SIZE	DESCRIPTION	QTY
28	D322F-F2-B1	-	Reducer 1" MIPS x 1/4" FIPS	2
29	D320F-F1F1F1	-	Tee 1" IPS	2
* 30	D2390SP	-	Split Jam Nut	2
31	D207A-B8-38	-	Copper Tubing 1" CTS x 9 1/2" Lg.	2
32	D207A-B8-64	-	Copper Tubing 1" CTS x 16" Lg.	2
33	D207A-B10-18	-	Copper Tubing 1 1/4" CTS x 4 1/2" Lg.	1
34	D323F-F2-E1	-	Reducer 1 1/4" MIPS x 3/4" FIPS	1
35	D323F-E2-D1	-	Reducer 3/4" MIPS x 1/2" FIPS	1
36	D320F-F1F1E1	-	Tee 1 1/4" IPS	2
37	D328F-E2A	-	Pipe Plug 3/4" IPS	1
38	925-48	A	Support Bracket	1
39	D-2266A	-	Pressure Regulator & Strainer 1 1/4" IPS	1
40	D316F-F1-F2	-	90° Street Elbow 1" IPS	2
41	D2363	-	Ball Valve 1 1/4" IPS	1
42	D207A-B8-152	-	Copper Tubing 1" CTS x 38" Lg.	1
43	925-49	A	Support Bracket	2
44	D72-A	A	Pipe Clamp	2
45	D316A-F3-F4	-	90° Elbow 1" C x 1" FTG	2
46	D328F-A2A	-	Pipe Plug 1/8" IPS	2
47	D207A-B8-80	-	Copper Tubing 1" CTS x 20" Lg.	1
48	D207A-B8-168	-	Copper Tubing 1" CTS x 42" Lg.	2
49	D320A-G3-F3-F3	-	Tee 1 1/4" C x 1" C x 1" C	1
50	D320F-G1-G1-G1	-	Tee 1 1/4" IPS	2
51	D316F-G1-G2	-	90° Street Elbow 1 1/4" IPS	1
52	D314F-GC-00	-	Nipple Close 1 1/4" IPS	3
53	D317A-F3-F2	-	Adapter 1 1/4" C x 1 1/4" MIPS	1
54	D316A-G3-G3	-	90° Elbow 1 1/4" C	1

**NOTE:**

Pressure Regulator/Strainer (Item 39) to be furnished by others unless specified on production card - use D-2448 "Y" Strainer as standard.

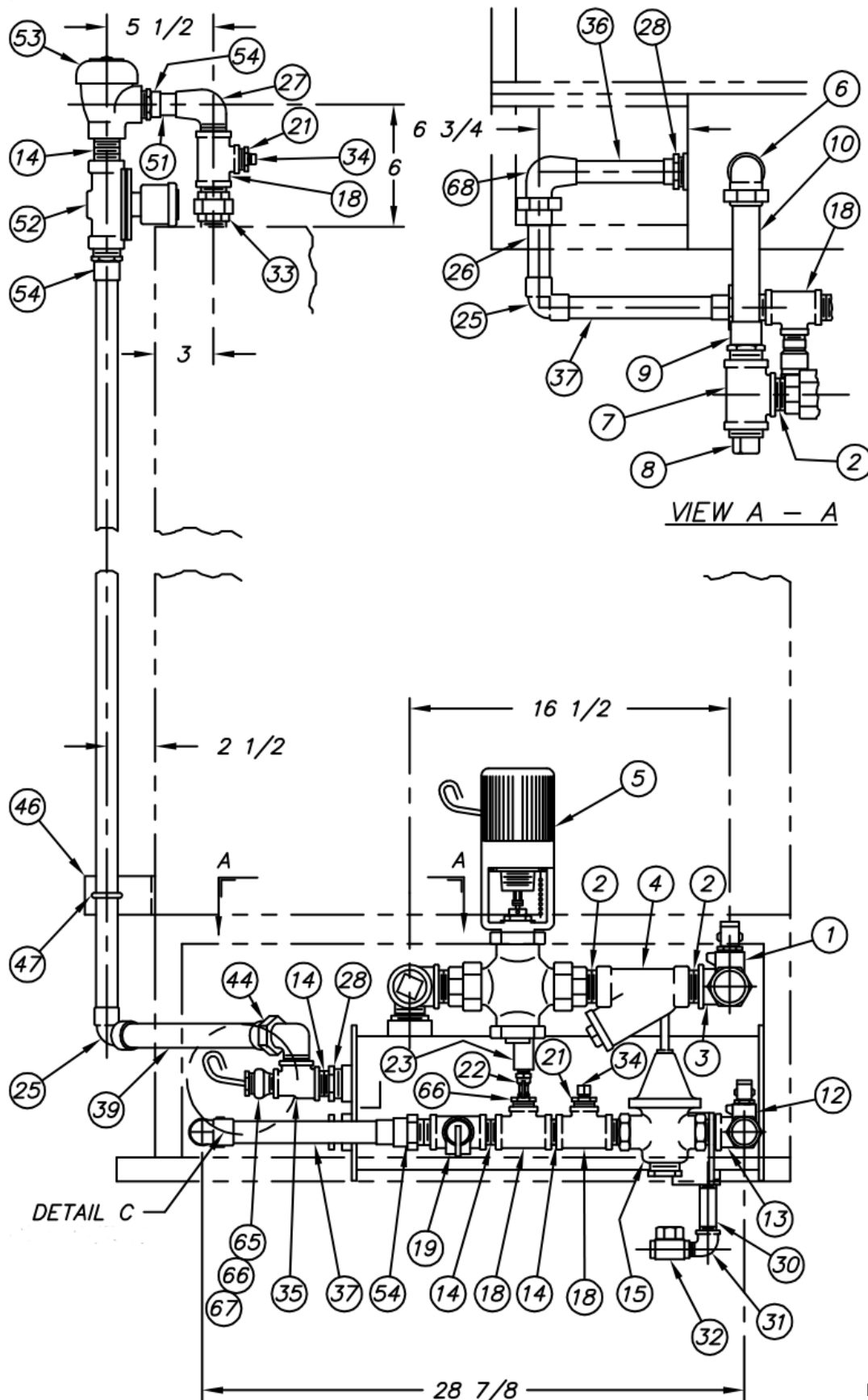
**1173-31 : DA-3 Final Rinse Piping with Two I-3 Boosters**

REV M - 03/09/18



**1173-31 : DA-3 Final Rinse Piping with Two I-3 Boosters**

ITEM	PART NO.	DESCRIPTION	QTY
1	D2363	Ball Valve 1 1/4" IPS	2
2	D314F-GC-00	Close Nipple 1 1/4" IPS	5
3	D316F-G1-G2	90° Street Elbow 1 1/4" IPS	2
4	D2447	"Y" Strainer 1 1/4" IPS	2
5	D2267	Steam Temperature Regulator 1 1/4" IPS	2
6	D319A-G3-G2	90° Union Elbow 1 1/4" C x 1 1/4" MIPS	2
7	D320F-G1G1G1	Tee 1 1/4" IPS	2
8	D328F-G2A	Square Plug 1 1/4" IPS	2
9	D317A-G3-G2	Adapter 1 1/4" MIPS x 1 1/4" C	2
10	D207A-B10-33	Copper Tubing 1 1/4" CTS x 8 1/4" Lg.	1
11	D322F-H2-G1	Hex Reducer 1 1/2" MIPS x 1 1/4" FIPS	2
12	D2379	Ball Valve 1" IPS	2
13	D316F-F1-F2	90° Street Elbow 1" IPS	4
14	D314F-FC-00	Close Nipple 1" IPS	15
15	D2266	Pressure Regulator & Strainer 1" IPS	2
16	979-24	Bracket	1
17	D2243	I-3 Booster (21")	2
18	D320F-F1F1E1	Tee 1" FIPS x 1" FIPS x 3/4" FIPS	7
19	D2507	Pressure Relief Valve 3/4" IPS	2
20	-	-	-
21	D322F-E2-A1	Hex Reducer 3/4" MIPS x 1/8" FIPS	4
22	D2497	Petcock 1/4" IPS	2
23	SK-1433	Pressure Gauge 1/4" IPS	2
24	D207A-B10-22	Copper Tubing 1 1/4" CTS x 5 1/2" Lg.	2
25	D316A-F3-F3	90° Elbow 1" C	6
26	D207A-B8-20	Copper Tubing 1" CTS x 5" Lg.	3
27	D316A-F3-F2	90° Elbow 1" C x 1" MIPS	2
28	D322F-G2-F1	Hex Reducer 1 1/4" MIPS x 1" FIPS	4
29	D332F-E2-D1	Hex Reducer 3/4" MIPS x 1/2" FIPS	2
30	D314F-DS-24	Nipple 1/2" IPS x 3" Lg.	2
31	D316F-D1-D2	90° Street Elbow 1/2" IPS x 1/2" MIPS	2
32	D2102A	Steam Trap 1/2" IPS	2
33	D318F-F1-F1	Street Union 1" FIPS x 1" FIPS	2
34	D328F-A2A	Square Plug 1/8" IPS	4
35	D320F-F1E1F1	Tee 1" FIPS x 3/4" FIPS x 1" FIPS	2
36	D207A-B8-18	Copper Tubing 1" CTS x 4 1/2" Lg.	2

**NOTE:**

Pressure Regulator/Strainer (Item 15) to be furnished by others unless specified on production card - use D-2447 "Y" Strainer as standard.

**1173-31 : DA-3 Final Rinse Piping with Two I-3 Boosters**

ITEM	PART NO.	DESCRIPTION	QTY	
37	D207A-B8-	Copper Tubing 1" CTS x 10 5/8" Lg.	2	
38	925-48	Bracket	1	
39	D207A-B8-108	Copper Tubing 1" CTS x 27" Lg.	1	
40	D207A-B8-44	Copper Tubing 1" CTS x 11" Lg.	1	
41	D207A-B8-222	Copper Tubing 1" CTS x 55 1/2" Lg.	1	
42	D207A-B8-218	Copper Tubing 1" CTS x 54 1/2" Lg.	1	
43	D207A-B10-52	Copper Tubing 1 1/4" CTS x 13" Lg.	1	
44	D319A-F3-F2	Union Elbow 1" C x 1" MIPS	2	
45	D316A-G3-G3	90° Elbow 1 1/4" C	2	
46	925-49	Bracket	2	
47	D72A	Pipe Clamp	2	
48	979-42	S/S Upper Rinse Pipe	2	
49	D207C-L7-73	S/S Tubing 7/8" OD x 18 1/4" Lg.	2	
50	D314F-GS-48	Nipple 1 1/4" x 6" Lg.	1	
51	D207A-B8-12	Copper Tubing 1" CTS x 3" Lg.	2	
52	D2944	Solenoid Valve 1" IPS	2	
53	D2249	Vacuum Breaker 1" IPS	2	
54	D317A-F3-F2	Adapter 1" C x 1" MIPS	8	
55	D314F-GA-20	Nipple 1 1/4" IPS x 2 1/2" Lg.	1	
56	D207A-B8-16	Copper Tubing 1" CTS x 4" Lg.	2	
*	57	D318E-E3-E2	Street Union 3/4" C x 3/4" MIPS	4
	58	D207C-L7-168	S/S Tubing 7/8" OD x 42" Lg.	2
*	59	D316E-E3-E3	90° Elbow 3/4" C	2
	60	D326F-F1	Lock Nut 1" IPS	2
	61	D314C-ES-14	Nipple 3/4" IPS x 1 3/4" Lg. S/S	2
	62	593-24	Cross 1" x 3/4" x 3/4" x 1/2" FIPS	2
*	63	D316E-E3-E1	90° Elbow 3/4" C x 3/4" FIPS	2
*	64	D316E-E3-E2	90° Elbow 3/4" C x 3/4" MIPS	2
*	65	D2390SP-1	Brass Union	2
	66	D322F-E2-B1	Hex Reducer 3/4" MIPS x 1/4" FIPS	2
*	67	D2390SP	Split Jam Nut	2
	68	D319A-F3-F3	Union Elbow 1" C x 1" C	2
*	69	D315E-E3-E3	45° Elbow 3/4" C x 3/4" C	2
*	70	D315E-E3-E4	45° Elbow 3/4" C x 3/4" CFTG	2
	71	D319A-G3-G2	Union Elbow 1 1/4" C x 1 1/4" MIPS	1

\* Nickel Plated Copper or Brass

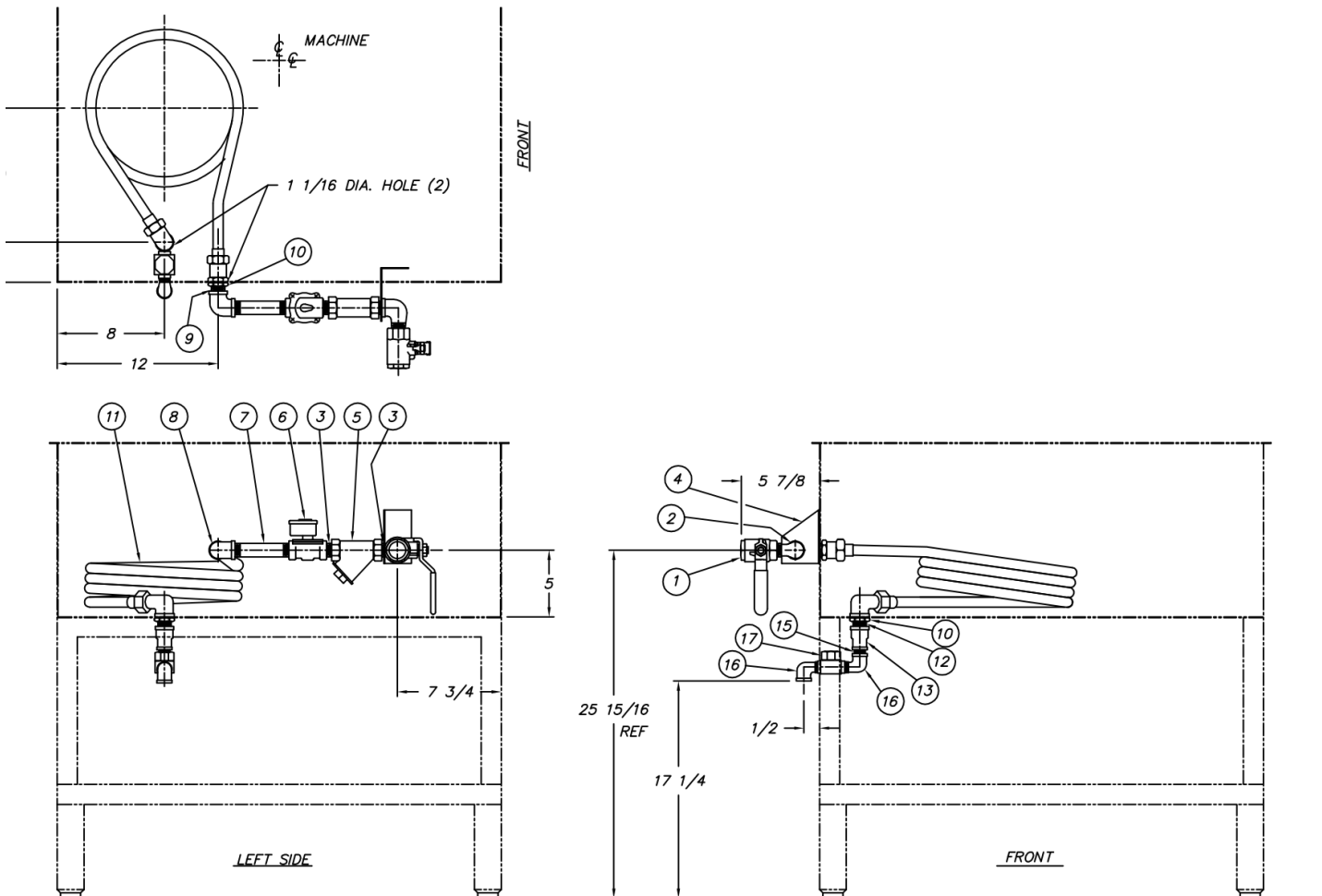
**1172-49 : Steam Coil (Solenoid Operated)**

REV B - 10/19/01

ITEM	PART NO.	DESCRIPTION	QTY
1	D-2340	Ball Valve 3/4" IPS	1
2	D316F-E1-E2	90° Street Elbow 3/4" IPS	1
3	D314F-EC-00	Close Nipple	2
4	562-115 (DWG.)	Steam Pipe Bracket	1
5	D-2482	"Y" Strainer 3/4" IPS	1
6	D-2595	Solenoid 3/4" IPS	1
7	D314F-ES-36	Nipple 3/4" IPS x 4 1/2" Lg.	1
8	D316F-E1-F1	90° Elbow 3/4" IPS	1
9	D314F-EA-16	Nipple 3/4" IPS x 2 Lg. (All Thread)	1
10	D326F-F1	Lock Nut 3/4" IPS	2
11	704-33A (DWG.)	Steam Coil - Copper (#704-33 = Coil)	1
12	D314F-EA-12	Nipple 3/4" IPS x 1 1/2" Lg. (All Thread)	1
13	D321F-E1-D1	Coupling Reducing 3/4" FIPS x 1/2" FIPS	1
14	-	-	-
15	D314F-DC-00	Close Nipple 1/2" IPS	1
16	D316F-D1-D2	90° Street Elbow 1/2" MIPS x 1/2" FIPS	2
17	D-2102A	Steam Trap 1/2" IPS	1

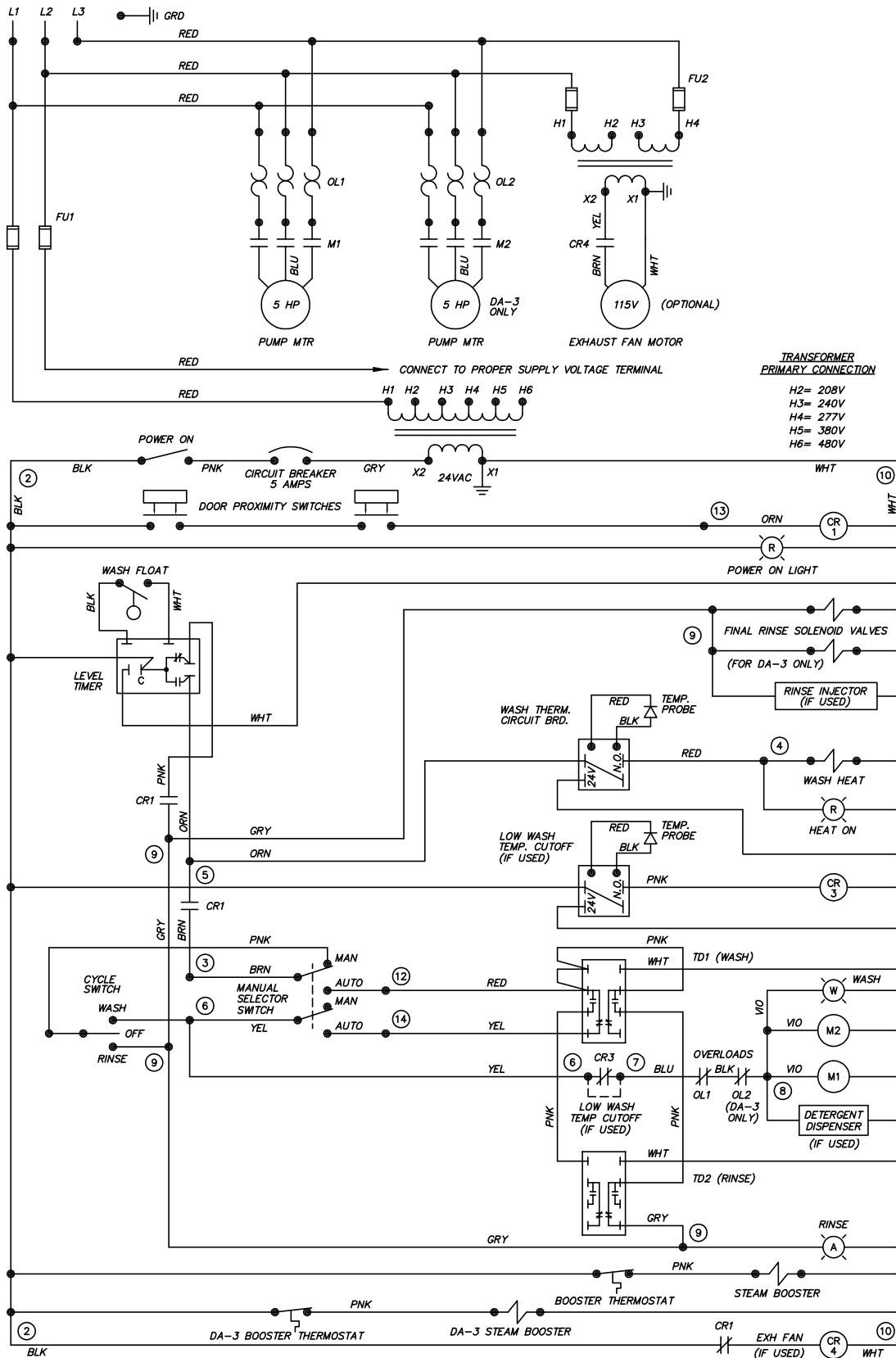

**NOTES:**  
 1. IF NO LOW TEMP CUTOFF IS SPECIFIED, A JUMPER IS PROVIDED BETWEEN TERMINALS 6 & 7.

P		1583	12.1.97	<b>Insinger</b> Philadelphia, PA 19135 (215) 624-4800 FAX (215) 624-6966	DRWN/DATE RAF 06.25.95
REV	ECN NO	DATE	FILE: WIRE\WPW010		
TITLE			CA-3, DA-3 STEAM HEAT	DWG. NO. WPW010	



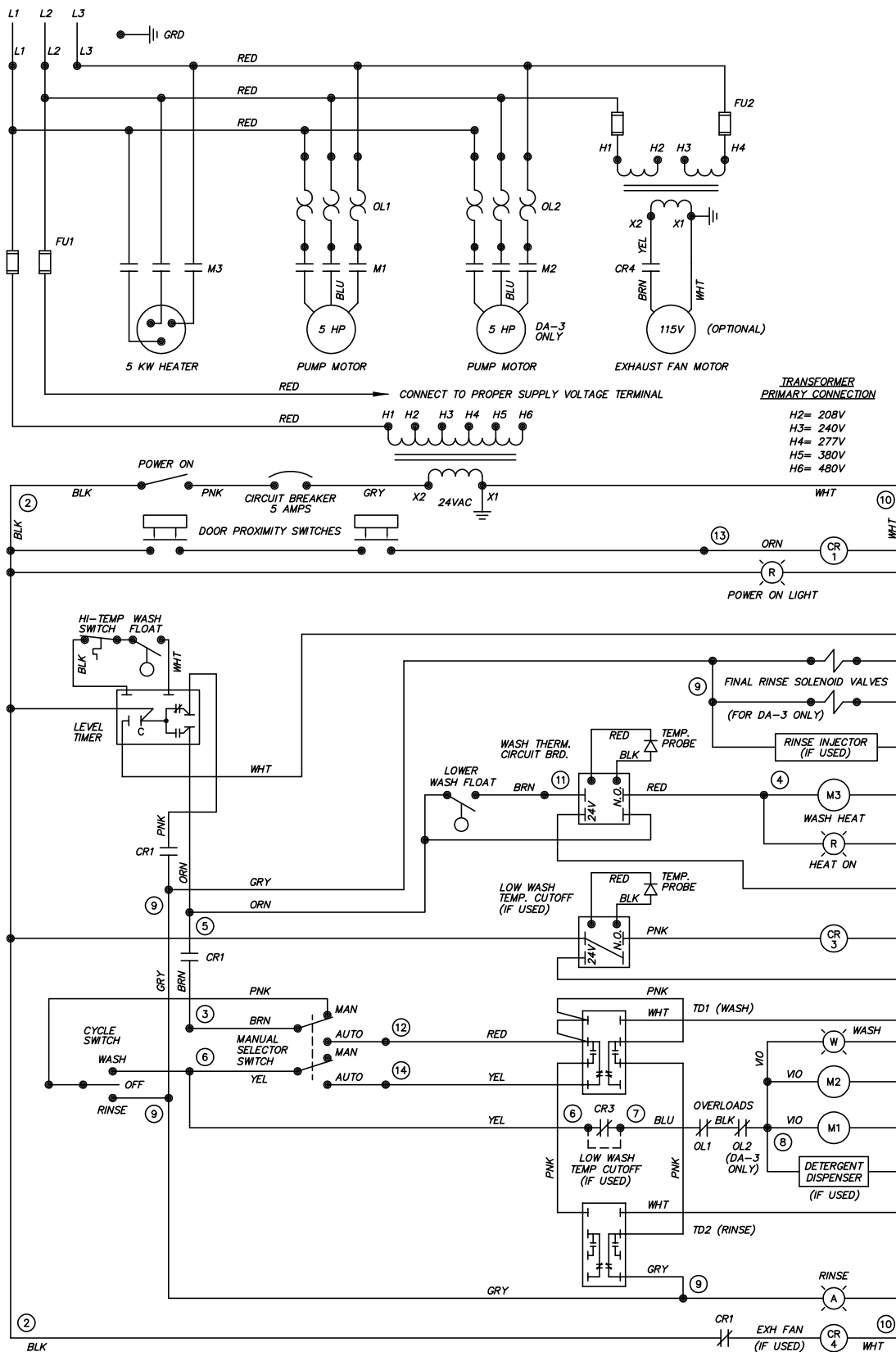

**NOTES:**  
 1. IF NO LOW TEMP CUTOFF IS SPECIFIED, A JUMPER IS PROVIDED BETWEEN TERMINALS 6 & 7.

		TITLE	CA-3, DA-3 ELECTRIC HEAT	DWG. NO.	WPW020
R	1988	7.7.03			
Q	1824	11.13.00			
REV	ECN NO	DATE	Philadelphia, PA 19135 (215) 624-4800	DRWN/DATE	RAF
FILE:	WIRE\WPW020		FAX (215) 624-6966		06.23.95

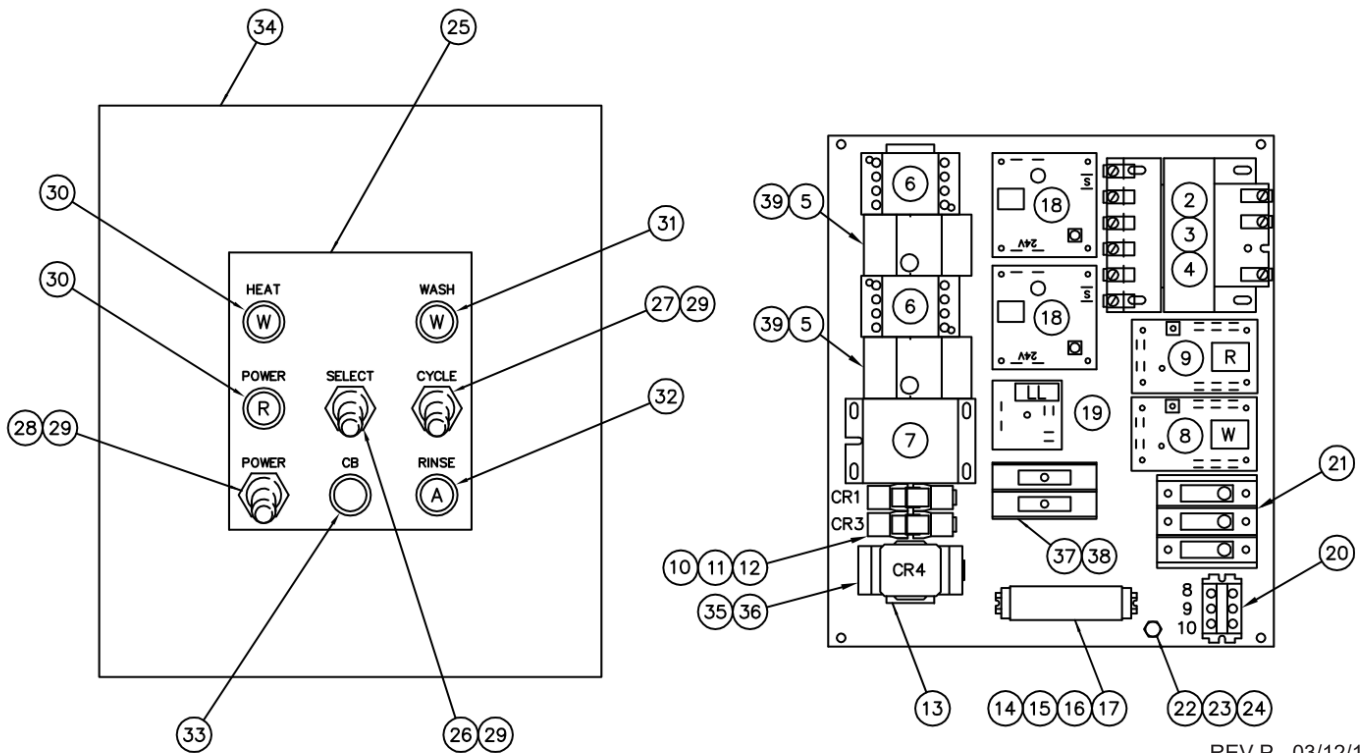
**SK-3241 : Control Panel Layout**

REV P - 03/12/18

ITEM	PART NO.	DESCRIPTION	QTY
1	SK-3825	Component Mounting Plate	1
2	DE6-9	Transformer (150 VA, 24 VAC)	1
3	DE9-164	Fuse Block Kit (150 VA XFMR)	1
4		<b>Fuse (150 VA Transformer Primary)</b>	2
	DE9-167	460V, FNQ-R-1	
	DE9-199	380V, FNQ-R-1.25	
	DE9-170	220V - 230V, FNQ-R-2	
	DE9-171	208V, FNQ-R-2.25	
5		<b>Overload Relay (Pumps)</b>	AR
	DE2-55	460/3/60, 5.5 - 8A	
	DE2-56	380/3/50, 7 - 10A	
	DE2-58	230/3/60, 12 - 18A	
	DE2-58	220/3/50, 12 - 18A	
	DE2-58	208/3/60, 12 - 18A	
6	DE1-93	Contactors (Pumps) SP4	AR
7	DE1-109	Contactors (Electric Tank Heat) 30A Res	1
8	DE7-28	Time Delay Board (Wash)	1
9	DE7-27	Time Delay Board (Rinse)	1
10	DE2-37	Relay Base	AR
11	DE2-38	Relay	AR

**SK-3241 : Control Panel Layout**

ITEM	PART NO.	DESCRIPTION	QTY
12	DE3-43	Relay Hold Down Spring	AR
13	DE9-84	DIN Rail (35mm)	1
14	DE3-42	DIN Rail (15mm)	1
15	DE3-39	Terminal Section	16
16	DE3-40	Terminal End Cover Plate	1
17	DE3-41	Terminal End Clamp	2
18	DE9-251	Temperature Control Board	AR
19	DE7-35	Timer (Liquid Level)	1
20	DE3-9	Terminal Block Assembly	1
21	DE3-152	Distribution Block	1
22	D309C-GC-4G	Grounding Stud, 1/4-20	1
23	D313C-G5	Lockwasher 1/4"	1
24	D312C-GC-2	Hex Nut, 1/4-20	1
25	SK-2622	Legend Decal	1
26	DE5-11	Selector Switch	1
27	DE5-16	Cycle Switch	1
28	DE5-11	Switch, DPDT (Power On)	1
29	DE9-13	Boot	3
30	DE9-107	Pilot Light (Heat & Power On)	1
31	DE9-108	Pilot Light (Wash)	1
32	DE9-109	Pilot Light (Rinse)	1
33	DE9-43	Circuit Breaker (5A)	1
34	979-23	Control Box	1
35	DE2-12	Relay	1
36	DE3-25	Relay Base	1
37	DE9-185	Fuse Block (100 VA Fan XFMR)	1
38		<b>Fuse 100 VA Transformer</b>	2
	DE9-166	460V, FNQ-R-.75	
	DE9-168	220 - 230V, FNQ-R-1.4	
	DE9-200	208V, FNQ-R-1.5	
39	DE2-60	Overload Base	AR
<b>PARTS NOT SHOWN</b>			
-		<b>Electric Immersion Heater (5 kW)</b>	1
	DE13-SD73	440 - 480V, 3 PH	
	DE13-SD53	380V, 3 PH	
	DE13-SD43	220 - 240V, 3 PH	
	DE13-SD23	208V, 3PH	
-	DE6-34	Dry XFMR (100 VA For Fan)	1
-	DE9-252	Temperature Sensor	AR



Insinger Machine Company  
6245 State Road  
Philadelphia, PA 19135-2996  
800-344-4802  
Fax: 215-624-6966  
[www.insingermachine.com](http://www.insingermachine.com)