



ESSENTIAL SERIES

Project _____
Item _____
Quantity _____
CSI - 11400 _____
Approval _____
Date _____

RACK-A-MATIC Warewashing System

- Adaptable to almost any space allocation
- Unit choice of rack conveyor dishwashers
(See individual specification sheets for each dishmachine)
- Labor efficiency is increased by endless conveyor design
- Systems can be furnished with any type of shelving, disposer, troughs, tray rests or other accessories to meet specific needs

STANDARD FEATURES

- Drive unit
- S/S conveyor drive chain
- Two 180° curve system
- 14 gauge S/S pan system
- Field joints
- Cross scrap trough with scrap screen
- Factory supervision of assembly (Continental U.S.)

OPTIONS

- S/S double adjustable overhead shelf (one slanted, one flat) with supports
- S/S garbage trough area
- S/S curve landing shelf
- Waste disposer unit complete with control package (which will be fitted to garbage trough area)
- Security package
- Signature conveyor series

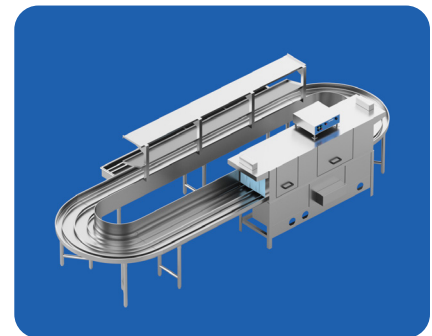
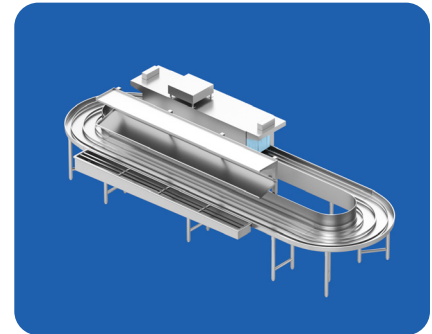

Systems can be furnished with any type of shelving, disposer, troughs, tray rests or other accessories to meet specific needs

