



ESSENTIAL SERIES

Project _____
 Item _____
 Quantity _____
 CSI - 11400 _____
 Approval _____
 Date _____

SMART-SCRUBBER SERIES

Pot and Pan Washing System

- Automatic scrub sink that creates the same turbulent whirlpool pattern as our Quadjet Aqua-Scrubber at a SMART price point
- Simplified design
- SMART controls – pump on/off and heat on/off
- 1 hp pump motor and a heat source that is not immersed in the water makes this sink a SMART value
- 16 gauge stainless steel construction with a rolled front edge and hemmed edge sides
- 11" backsplash
- The SMART alternative to a standard 3 compartment sink at a very attractive price
- Available in 96", 112" and 136" widths

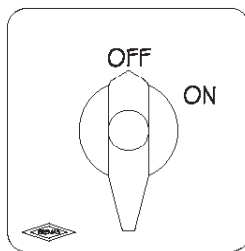

PUMP

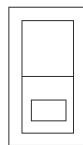

HEAT

STANDARD FEATURES

- Six high velocity water jets create a turbulent whirlpool action for effective cleaning
- 120V 20.0A circuit is all that is required for the 1 hp pump motor and heat source
- Basket style high capacity lever action waste drain
- Single point electrical connection
- Welded support legs with stainless steel feet
- 300 series stainless construction

OPTIONS

- Sink overflows
- End splash
- Scrapper drainboard with pre-rinse faucet (112" and 136" units only)
- Clean side undershelf (112" and 136" units only)





SMART-SCRUBBER SERIES

Pot and Pan Washing System

SPECIFICATIONS

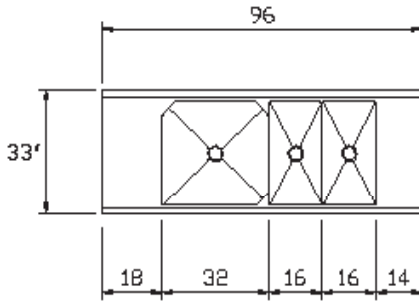

SmartScrubber 96

- 32" Wash Bowl
- 16" Rinse Sink
- 16" Sanitize Sink
- 18" Soiled Drainboard
- 14" Clean Drainboard

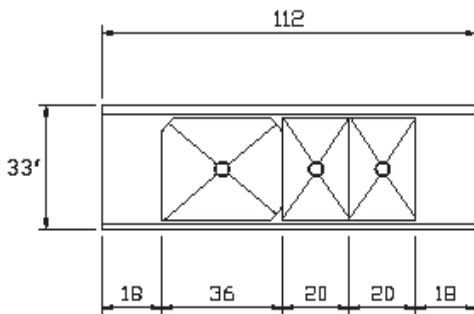

SmartScrubber 112

- 36" Wash Bowl
- 20" Rinse Sink
- 20" Sanitize Sink
- 18" Soiled Drainboard
- 18" Clean Drainboard

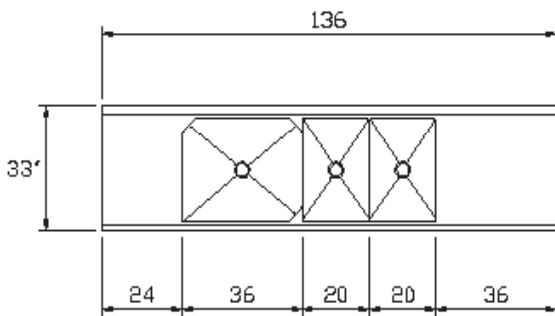

SmartScrubber 136

- 36" Wash Bowl
- 20" Rinse Sink
- 20" Sanitize Sink
- 24" Soiled Drainboard
- 36" Clean Drainboard

Note: For all rough in connections see installation and layout detail drawing.

CONSTRUCTION- Entire unit constructed of 300 series polished stainless steel.

TOP- constructed of 16 gauge stainless steel all welded with integral back splash in rear, rolled front rim and hemmed edge sides.

WASH SINK BOWL- 16 gauge stainless steel all welded integral with top. Bottom corners covered to 3/4" radius. All vertical mitred corners covered to 1/4" radius. Crease bottom to drain opening. Stud bolt support channels to bottom of sink bowls. Water pump assembly and hinged intake cover on soiled drainboard side of sink bowl. Six (6) water discharge openings. Heated mat applied to exterior of bowl and covered with fiberglass insulation and 20 gauge stainless steel covering.

RINSE AND SANITIZE BOWLS- 16 gauge stainless steel all welded integral with top. Bottom corners covered to 3/4" radius. Crease bottom to drain opening. Stud bolt support channels to bottom of sink bowls.

SUPPORT CHANNELS- 3 1/2" X 3/4" X 14 gauge stainless steel channels with hemmed edges.

CROSSRAILS- 1 1/4" O.D. stainless steel tubing fastened to legs with cross brace fittings. Welded front to back cross rails.

LEGS AND FEET- 1 5/8" O.D. stainless steel tubing fitted with stainless steel adjustable feet. Held in conical leg holders with set screw.

APRON- 20 gauge stainless steel.

WASH TANK CONTROL PANEL- 14 gauge stainless steel with gasketed, hinged door. Waterproof construction, mounted under soiled drainboard.

ELECTRICAL REQUIREMENTS

120V, 60HZ, 1-PHASE

TOTAL LOAD: 16.3 AMPS

NEMA CONFIGURATION

LOCKING PLUG

3-WIRE, GROUNDING

20 AMP, 125 VOLT

1-PHASE

NEMA L5-20P

Shipping Weight	SmartScrubber 96"	495 lbs.
	SmartScrubber 112"	550 lbs.
	SmartScrubber 136"	675 lbs.

Note: Due to product improvement we reserve the right to change information and specifications without notice.

Contact Insinger Sales at 800-344-4802 for an installation drawing specific to your application.
This drawing is available on the Insinger website at www.insingermachine.com

Note: Due to product improvement we reserve the right to change information and specifications without notice.