



# **Insinger**

## **TECHNICAL MANUAL**

Installation, Operation and Maintenance Instructions

### **OUTPOST**

#### **HAND SANITIZING UNIT**

(FOOT PEDAL OPERATED)

(FLOOR / WALL MOUNTED)

Insinger Machine Company  
6245 State Road  
Philadelphia, PA 19135-2996

**800-344-4802**

Fax: 215-624-6966

[www.insingermachine.com](http://www.insingermachine.com)

***Thank you for purchasing a quality Insinger product.***

In the space provided below please record the model, serial number and Installation date of this unit:

Model: **OUTPOST**

Serial Number: \_\_\_\_\_

Start-Up Date: \_\_\_\_\_

When referring to this equipment please have this information available.

Each piece of equipment at Insinger is carefully tested before shipment for proper operation. If the need for service should arise please contact your local Authorized Insinger Service Company. To find your local authorized Service Company please visit our web site, [www.insingermachine.com](http://www.insingermachine.com) or call Insinger at 800-344-4802.

Please read all installation and operation instructions carefully before attempting to install or operate your new Insinger product.

For answers to question concerning installation, operation, or service contact our Technical Service Department.

**WARRANTY**  
THIS UNIT COMES WITH A 90 DAY  
PART DEFECT WARRANTY

<b>TECHNICAL SERVICE CONTACTS</b>	
Toll-Free	800-344-4802
Fax	215-624-6966
Email	<a href="mailto:service@insingermachine.com">service@insingermachine.com</a>
Website	<a href="http://www.insingermachine.com">www.insingermachine.com</a>

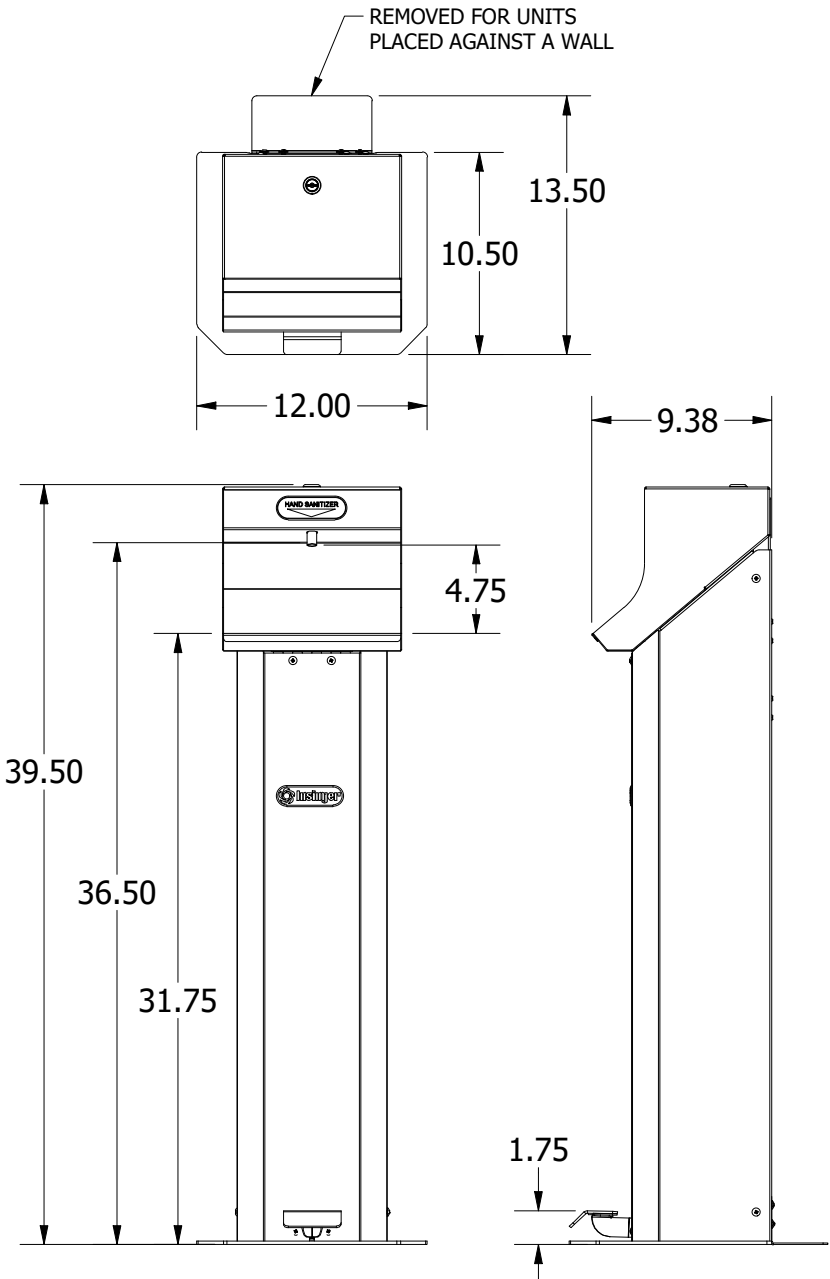

**INSTALLATION INSTRUCTIONS**

1. Carefully unbox the unit. Take caution not to damage components.
2. Remove any plastic film that may be covering steel metal parts.

**FOR UNITS PLACED AGAINST A WALL:**

1. Push unit as close to the wall as possible.
2. If desired, the unit can be secured to a wall by aligning a wall stud to one of the holes in the back of the unit and then fasten with appropriate screw.
3. If the unit is greater than 3 inches away from the wall, it is recommended that the rear foot be installed.

**FOR FREE STANDING UNITS:**

1. Unlock the units hood and tilt forward.
2. Locate the Rear Foot that is mounted to the upper back of the unit. Remove the foot and retain the 4 screws and the 4 lockwashers.
3. Install the Rear Foot to the back of the unit as illustrated. The slots will allow for a certain amount of leveling. Ensure that the base of the foot is in complete contact with the floor before tightening the screws.
4. Follow procedures to install a new bottle of sanitizing agent.

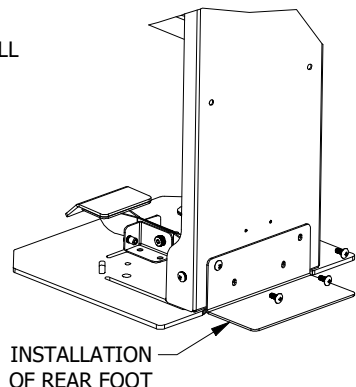
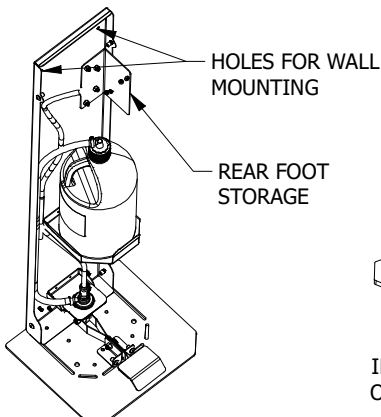

**INSTALLATION INSTRUCTIONS (Continued)****FOR BOLTED DOWN UNITS:**

1. Unlock the units hood and tilt foward.
2. Disconnect the discharge hose at the metal tubing in the hood cavity and remove the dress panel with its attached hood. There are 2 screws along each side at the back and 2 screws below the foot pedal for a total of 6 screws.
3. There are two holes in the base that are 6 inches apart that can be utilized to bolt the base down. Any bolts and / or anchoring points are entirely the responsibility of the customer.
4. After securing base, Reinstall the Dress Panel with the attached Hood.
5. Reconnect the Hose to the metal tubing leading to the nozzle.
6. Follow bottle changing procedures to provide sanitizing agent to the unit.
7. Tilt the Hood back into position and lock the unit.

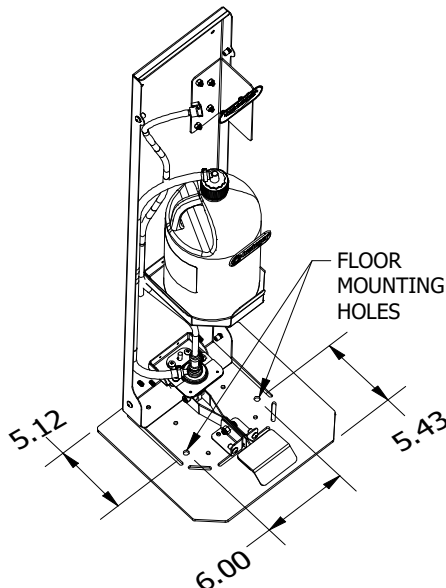

**OPERATING INSTRUCTIONS**

1. Place hand / hands under the dispensing nozzle located above the catch tray.
2. Slowly step down upon the foot pedal located at floor level at the front of the unit.
3. The sanitizing agent will be dispensed onto your hands in a fine mist for alcohol based sanitizers and in a stream for sanitizing gels.
4. After the spray stops, release the foot pedal.
5. If additional sanitizing agent is desired, repeat the process.
6. Rub hands together thoroughly for 30 seconds to ensure that all areas of your hands are covered.

**NOTE:**

If sanitizing agent is not present after repeated attempts, ensure that the bottle is not empty. If a replacement bottle is necessary, follow the instructions on the next page.

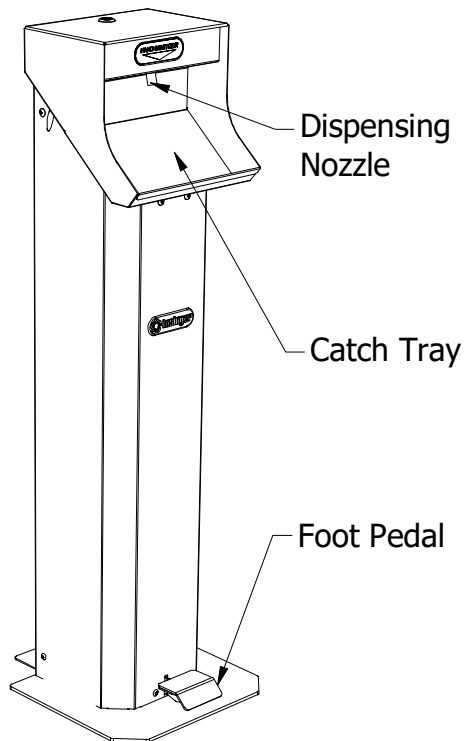

**BOTTLE REPLACEMENT**

**WARNING:**  
WEAR PROTECTIVE FACE SHIELD  
OR GOGGLES TO PREVENT CHEMICAL  
AGENTS CONTACTING YOUR EYES

1. Obtain the key for the hood lock and turn the lock counterclockwise.
2. Tilt the Hood forward to expose the sanitizer bottle. Inspect the bottle to ensure the sanitizer level. If sanitizing level is adequate, check for other conditions that would prevent the dispensing of sanitizing agent. (Refer to the troubleshooting section)
3. If the level is inadequate, remove the bottle top by rotating counterclockwise and then pull the cap and its attached suction hose from the old bottle. Secure the bottle top with connected hose to prevent it from falling down into the base of the unit.  
**(Elevating the hose will prevent the loss of any liquid within the hose and will make priming of the new bottle easier).**
4. Remove the old bottle from its holding tray.
5. Obtain a new bottle of sanitizing agent and place it upon the holding tray.
6. Remove the new bottles cap and any protective seal that may be present.
7. Insert the Suction Hose into the new bottle and secure the bottle cap by turning clockwise until snug.
8. Slowly and repeatedly press the foot pedal downward and release until sanitizing agent is visible within the hose and approaches its end. This will take several pushes to expell all air from the lines.

**BOTTLE REPLACEMENT (Continued)**

9. Close the Dispenser Hood while ensuring the discharge hose does not become kinked in the process.
10. Lock the hood by turning the key in the clockwise direction.
11. Operate the dispenser to ensure that the sanitizing agent flows freely.



## **CLEANING INSTRUCTIONS**

### **DAILY CLEANING**

The following cleaning procedures should be done daily, at the end of the shift:

1. Wipe up any sanitizing liquid that may have accumulated in the catch tray.
2. Ensure any sanitizing liquid that may have dropped on the floor from the hands of people during normal use is wiped up.

## **MAINTENANCE REQUIREMENTS**

**This section is intended for qualified service and/or maintenance technicians.**

**The following maintenance should be conducted if any operational problems develop:**

1. Unlock the units hood and tilt forward.
2. Inspect the condition of all hoses / tubes and fittings. Look for sanitizing liquid leaks.
3. Disconnect the discharge hose at the tubing leading to the nozzle and remove the dress panel with its attached hood. There are 2 screws along each side at the back and 2 screws below the foot pedal for a total of 6 screws.
4. Inspect the pump for cracks and any loose hoses .
5. Press the foot pedal downward and release. The internal spring of the pump should return the foot pedal to the upward position.
6. Verify that the nozzle sprays sanitizing agent freely. Remove any hardened buildup that may prevent proper flow.
7. Reinstall the Dress Panel / Hood combination. Reconnect the discharge hose to the metal tubing leading to the nozzle.
8. Tilt the Hood Back and lock the unit.

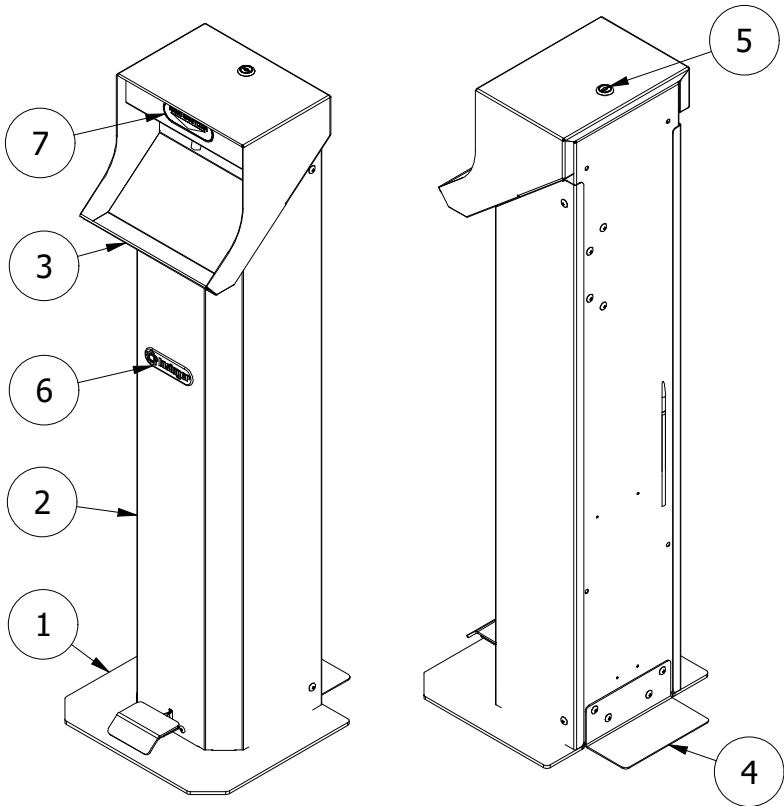
**PARTS LIST**

ITEM	QTY	PART NUMBER	DESCRIPTION
1	1	7100-02234	W-Base Weldment
2	1	7000-02236	F-Panel, Base Cover
3	1	7100-02235	W-Hood Weldment
4	2	7000-02247	F-Foot, Rear Support
5	1	6330-02261	Lock, Keyed Cam
6	1	9600-02307	Decal, Insinger
7	1	9600-02308	Decal, Hand Sanitizer
8	4	6310-02331	Foot, 1" Pad (NOT SHOWN)

<b>REV</b>	
------------	--

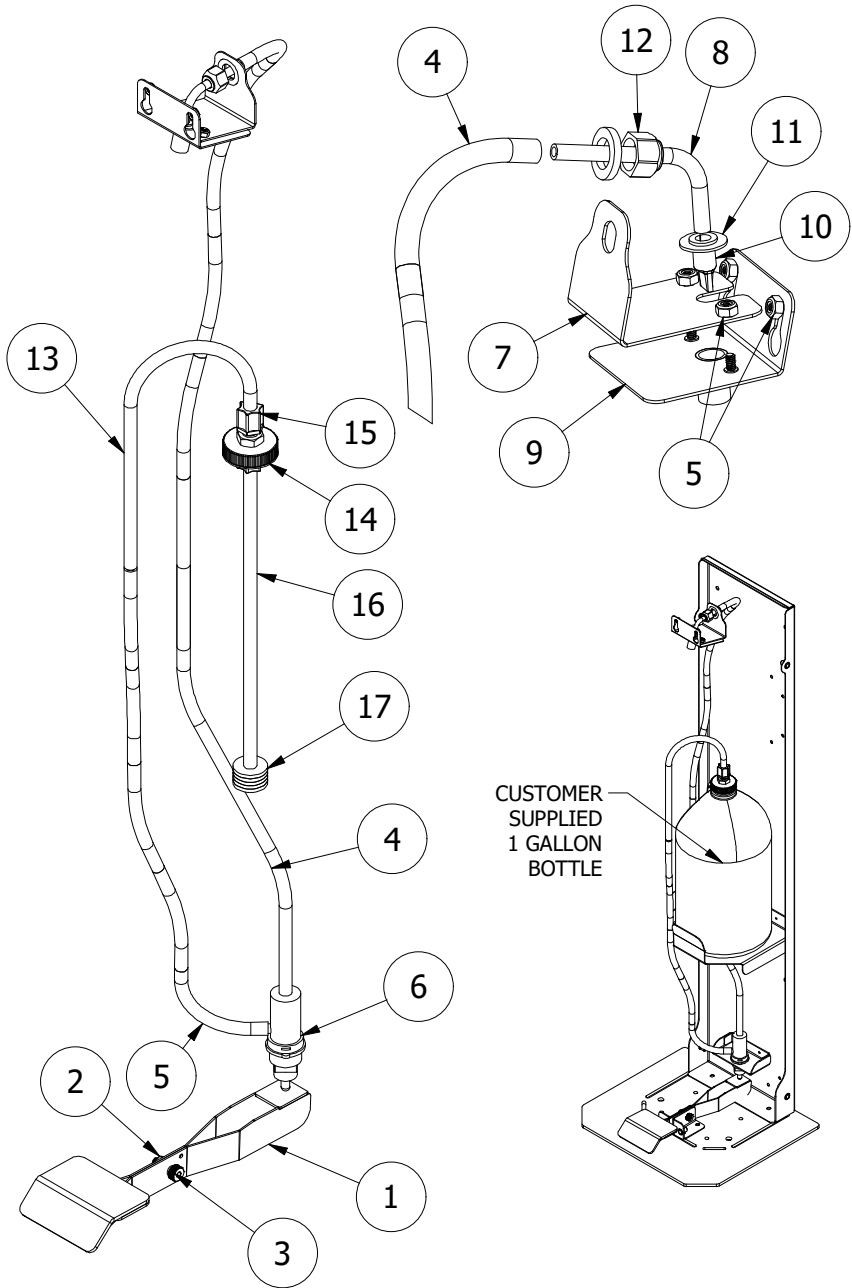

REV	
-----	--

PARTS LIST			
ITEM	QTY	PART NUMBER	DESCRIPTION
1	1	7100-02233	Foot Lever Weldment
2	2	5325-00392	Locknut, 1/4-20 Nylon Insert
3	1	5305-02248	Srew, Shoulder 5/16"x1/4-20
4	1	7500-02244	Hose, Discharge
5	4	5325-00556	Nut, #6-32 Locknut Nylon S/S
6	1	6125-02317	Pump, Piston Type w/Spring
7	1	7000-02283	Plate, Nozzle Positioning
8	1	7500-02287	Tube, Nozzle Supply
9	1	7100-02255	Bracket, Nozzle Positioning
10	1	4575-02312	Nozzle, Duckbill
11	1	5330-01486	Washer, 5/16" SS
12	1	5915-02319	Fitting, Liquid Tight Snap-In
13	1	7500-02243	Hose, Suction
14	1	3200-02325	Cap, 1-1/2" OD Jug Opening
15	1	4820-02321	Fitting, Straight Connector
16	1	7500-02330	Hose, Bottle Suction
17	1	7100-02369	Weight, Suction Tube

<b>REV</b>	
------------	--