



TECHNICAL MANUAL
Chemical Sanitizing Door Type Dishwashing Machine

CS-5

CS-5H

Installation, Operation and Maintenance Instructions

Insinger Machine Company
6245 State Road
Philadelphia, PA 19135-2996

800-344-4802
Fax 215-624-6966
www.insingermachine.com

Thank you for purchasing this quality Insinger product.

On the space provided below please record the model, serial number and start-up date of this unit:

Model: _____

Serial Number: _____

Start-Up Date: _____

When referring to this equipment please have this information available.

Each piece of equipment at Insinger is carefully tested before shipment for proper operation. If the need for service should arise please contact your local Authorized Insinger Service Company.

A Service Network Listing is provided on our web site, www.insingermachine.com or call Insinger at 800-344-4802 for your local authorized servicer.

For proper activation of the Insinger Limited Warranty a SureFire™ Start-Up & Check-Out Service should be completed on your machine. Refer to the Introduction section in this manual for an explanation of Insinger SureFire™ Start-Up & Check-Out Program.

Please read the Insinger Limited Warranty and all installation and operation instructions carefully before attempting to install or operate your new Insinger product.

To register your machine for warranty by phone, fax or the internet or for answers to question concerning installation, operation, or service contact our Technical Services Department:

TECHNICAL SERVICE CONTACTS	
Toll-Free	800-344-4802
Fax	215-624-6966
e-mail	service@insingermachine.com
Web site	www.insingermachine.com

TABLE OF CONTENTS

Part 1	1-8
Technical Information	
• Catalog Cut-sheet	
• Introduction	
• Warranty	
Part 2	9-14
Installation Instructions	
• Installation Drawing	
Part 3	15-19
Operating Instructions	
• Operation and Cleaning Instructions	
• Maintenance and Repair Procedures	
• Basic Service Guide	
Part 4	20-44
Electrical Schematics & Replacement Parts	
• Machine Wiring Diagrams	
• Control Panel Layout and Component Drawing	

 Project _____ CSI - 11400 _____
 Item _____ Approval _____
 Quantity _____ Date _____

CS-5

Automatic Single Tank Door Type Chemical Sanitizing Dishwasher

- Automatic door type, single tank dishwasher with timed wash and rinse cycle
- 0.72 gallon/rack
- Capacity is 65- 20" x 20" racks per hour or 1625 dishes per hour
- Fully automatic operation
- RackAware™ Automatic Rack Sensing System only runs a cycle when a rack is present
- Selectable 2 minute extended wash cycle
- Field convertible straight through to corner
- Digital temperature indicators for wash and rinse temperature



RackAware™ Automatic Rack Sensing System* only runs a cycle when a rack is present

STANDARD FEATURES

- SureFire® Start-Up & Check-Out Service
- Non-proprietary commercially available pump motor and parts
- "Easy Clean" front-mounted wash tank
- Single scrap screen design
- Tank heat: 5 Kw electric immersion heater or steam injectors
- Top-mounted NEMA 12 control panel
- Single point electrical connection: motor, controls and heater
- Door safety switch
- Low water protection
- Override switch for de-liming or extended wash cycle on front control panel
- Vent fan connection provision
- Easy-glide doors
- Detergent connection provision
- Manifold clean-out brush
- S/S frame, legs and feet
- S/S front panel
- End caps/pipe plugs secured to prevent loss
- Adjustable chemical sanitizing injection pump (supplies by others)

OPTIONS

- Pressure reduction valve and line strainer
- Stainless steel steam coil tank heat
- Security package
- Totally enclosed motor
- Door activated drain closer
- Plastic 20" x 20" racks (plate or silver)

AUTOQUOTES



CS-5



CS-5
Automatic Single Tank Door Type
Chemical Sanitizing Dishwasher

Capacity Per Hour	65 racks 1625 dishes 80-160 meals	
Tank Capacity	6.4 gallons	
Motor Size	1 hp (wash)	
Electric Usage	3.8 Kw 208v 5.0 Kw 240v 3.1 Kw 380v 5.0 Kw 480v	
Steam Consumption at 20 psi min.	11 lbs./hour tank	
Final Rinse Peak Flow at 20 psi min.	4.36 gallons/minute	
Final Rinse Consumption at 20 psi min.	47 gallons/hour 0.72 gallons/rack	
Exhaust Hood Requirement	400 cfm	
Peak Rate Drain Flow	9 gallons/minute	
Shipping Weight	400 lbs.	
Current Draw Amps	Steam	Electric
208/1/60	9.3	27.6
240/1/60	8.1	28.9
208/3/60	5.1	15.6
240/3/60	4.2	16.2
480/3/60	2.3	8.3
380/3/50	2.8	7.5

SPECIFICATIONS

CONSTRUCTION- Hood and tank constructed of 16 gauge type 304 S/S. Hood unit of all welded seamless construction. S/S frame, legs and feet. All internal castings are non-corrosive lead free nickel alloy or bronze.

DOORS- Three (both sides and front) simultaneously opening doors. Operating doors have fingertip control, balanced by externally mounted springs. (Corner installations have two simultaneously opening doors at right angles.) All doors have easy-glide strips. Extra large die formed type 304 S/S doors ride in all S/S channels. A triple ply leading edge on the door channels made of S/S.

PUMP- Centrifugal type "packless" pump with a brass petcock drain. Construction includes ceramic seal and a balanced cast impeller on a precision ground stainless steel shaft, extension or sleeve. All working parts mounted as an assembly and removable as a unit without disturbing pump housing. One 1 hp motor, standard horizontal C-face frame, drip proof, internally cooled with ball-bearing construction.

CONTROLS- Top mounted control cabinet, NEMA 12 rated, housing motor controls and overload protection, transformer, contactors and all dishwasher integral controls. Integrated rack sensing system.

SPRAY SYSTEM- Wash and rinse spray systems made of type 304 stainless steel pipe threaded into cast hub assemblies. Upper and lower wash and rinse spray assemblies are removable without the use of tools.

WASH- 2 power spinning wash arms above and 2 power spinning wash arms below. On top, each wash arm is designed with 8 nozzles (16 total). On the bottom, each wash arm is designed with 4 slots (8 total). The slots are precision milled for water control and produce a fan spray.

FINAL RINSE- 2 power spinning rinse arms above and 2 power spinning wash arms below. On top, each rinse arm is designed with 2 nozzles (4 total). On the bottom, each rinse arm is designed with 4 nozzles (8 total). The nozzles produce a fan spray reducing water consumption, maximizing heat retention.

DRAIN- Drain valve externally controlled. Overflow assembly with skimmer cap is removable without the use of tools for drain line inspection. Heater is protected by low water level control.

Note: Due to product improvement we reserve the right to change information and specifications without notice.

 Project _____ CSI - 11400 _____
 Item _____ Approval _____
 Quantity _____ Date _____

CS-5H

Automatic Extra High Single Tank Door Type Chemical Sanitizing Dishwasher

DESIGN

- Automatic door type, single tank dishwasher with timed wash and rinse cycle
- 0.72 gallon/rack
- Capacity is 65- 20" x 20" racks per hour or 1625 dishes per hour
- Fully automatic operation
- RackAware™ Automatic Rack Sensing System only runs a cycle when a rack is present
- Selectable 2 minute extended wash cycle
- Handles mixer agitators, 18" x 26" sheet pans, utensils & mixing bowls up to 60 quarts
- Field convertible straight through to corner
- Digital temperature indicators for wash and rinse temperature



RackAware™ Automatic Rack Sensing System* only runs a cycle when a rack is present

STANDARD FEATURES

- Door safety switch
- Detergent connection provision
- Fully automatic operation
- Non-proprietary commercially available pump motor
- Easily removable pump suction strainer
- Tank heat: 5 Kw electric immersion heater or steam injector
- SureFire® Start-Up & Check-Out Service
- Easy-glide doors
- Single point electrical connection: motor, controls and heater
- Top-mounted NEMA 12 control panel
- "Easy Clean" front-mounted wash tank
- Manifold clean-out brush
- S/S frame, legs and feet
- S/S front panel
- Low water protection
- Override switch for de-liming or extended wash cycle on front control panel
- Vent fan connection provision
- End caps/pipe plugs secured to prevent loss
- Adjustable chemical sanitizing injection pump (supplied by others)

OPTIONS

- Pressure reduction valve and line strainer
- Stainless steel steam coil tank heat
- Security package
- Totally enclosed motor
- Door activated drain closer
- Plastic 20" x 20" racks (plate or silver)



CS-5H

AUTOQUOTES



6245 State Road • Philadelphia, PA 19135 • PH: 800-344-4802 • FX: 215-624-6966 • www.insingermachine.com



CS-5H

Automatic Extra High Single Tank Door Type Chemical Sanitizing Dishwasher

Capacity Per Hour	65 racks 1625 dishes 80-160 meals	
Tank Capacity	6.4 gallons	
Motor Size	2 hp (wash)	
Electric Usage	5.0 Kw	
Steam Consumption at 20 psi min.	18 lbs./hour tank	
Final Rinse Peak Flow at 20 psi min.	4.36 gallons/minute	
Final Rinse Consumption at 20 psi min.	47 gallons/hour 0.72 gallons/rack	
Exhaust Hood Requirement	400 cfm	
Peak Rate Drain Flow	9 gallons/minute	
Shipping Weight	600 lbs.	
Current Draw Amps	Steam	Electric
208/1/60	13.7	32.0
240/1/60	11.9	33.3
208/3/60	8.0	21.9
240/3/60	7.2	19.2
480/3/60	3.6	12.0
380/3/50	4.4	9.6

SPECIFICATIONS

CONSTRUCTION- Hood and tank constructed of 16 gauge type 304 S/S. Hood unit of all welded seamless construction. S/S frame, legs and feet. All internal castings are non-corrosive lead free nickel alloy or bronze.

DOORS- Three (both sides and front) simultaneously opening doors. Operating doors have fingertip control, balanced by externally mounted springs. (Corner installations have two simultaneously opening doors at right angles.) All doors have easy-glide strips. Extra large die formed type 304 S/S doors ride in all S/S channels. A triple ply leading edge on the door channels made of S/S.

PUMP- Centrifugal type "packless" pump with a brass petcock drain. Construction includes ceramic seal and a balanced cast impeller on a precision ground stainless steel shaft, extension or sleeve. All working parts mounted as an assembly and removable as a unit without disturbing pump housing. One 2 hp motor, standard horizontal C-face frame, drip proof, internally cooled with ball-bearing construction.

CONTROLS- Top mounted control cabinet, NEMA 12 rated, housing motor controls and overload protection, transformer, contactors and all dishwasher integral controls. Integrated rack sensing system.

SPRAY SYSTEM- Wash and rinse spray systems made of type 304 stainless steel pipe threaded into cast hub assemblies. Upper and lower wash and rinse spray assemblies are removable without the use of tools.

WASH- 2 power spinning wash arms above and 2 power spinning wash arms below. On top, each wash arm is designed with 8 nozzles (16 total). On the bottom, each wash arm is designed with 4 slots (8 total). The slots are precision milled for water control and produce a fan spray.

FINAL RINSE- 2 power spinning rinse arms above and 2 power spinning wash arms below. On top, each rinse arm is designed with 2 nozzles (4 total). On the bottom, each rinse arm is designed with 4 nozzles (8 total). The nozzles produce a fan spray reducing water consumption, maximizing heat retention.

DRAIN- Drain valve externally controlled. Overflow assembly with skimmer cap is removable without the use of tools for drain line inspection. Heater is protected by low water level control.

Note: Due to product improvement we reserve the right to change information and specifications without notice.

**COMMANDER 18-6 DOOR TYPE
DISHWASHER SERIES****INTRODUCTION****Purpose**

The purpose of this technical manual is to provide installation, operation, cleaning and maintenance directions.

A section is provided for replacement parts.

Scope

This manual contains all pertinent information to assist in the proper installation, operation, cleaning, maintenance, and parts ordering for the Insinger Commander Series dishwashers.

The installation instructions are intended for qualified equipment installers. The operation and cleaning instructions are intended for the daily users of the equipment. The maintenance and parts sections are intended for qualified service and/or maintenance technicians. Replacement parts may be ordered directly from our factory or from your local Insinger Authorized Service Agency. You can speak to the Insinger Technical Services Department, 800/344-4802, or e-mail us at service@insingermachine.com. When calling for warranty information or replacement parts please provide the model and serial number of your Insinger Equipment. These important numbers should be noted in this manual on the spaces provided on the opening page.

Surefire™ Start-up & Check-out Program

Insinger is proud to offer our exclusive Surefire™ Start-up & Check-out Program to our commercial customers. This service is included in the purchase price of your new Insinger dishwasher. We will

provide an authorized factory service technician for the initial start-up of your new Insinger dishwasher to ensure it is running at optimum levels from the very first pass. Please call the factory or your local Insinger Sales Representative to schedule this service.

NSF 3-2008 requirements for detergent and chemical sanitizer dispensers.

This machine must be operated with an automatic detergent dispenser and, if applicable, an automatic chemical sanitizer feeder, including a visual means to verify that detergents and sanitizers are delivered or a visual or audible alarm to signal if detergents and sanitizers are not available for delivery to the respective washing and sanitizing systems. Please see instructions for electrical and plumbing connections located in this manual and in the feeder equipment manual.

Definitions

Throughout this guide you will find the following terms: **WARNING, CAUTION, & NOTE**.

WARNING indicates potential physical danger.

CAUTION indicates potential equipment damage.

NOTE indicates helpful operating hints or tips.

You will visually be able to identify each as shown below:

**NOTE:**

Indicates helpful operating hints or tips.

**WARNING:**

Indicates potential physical danger.

CAUTION:

Indicates potential equipment damage.

Door Type Dishwashing Machine

Safety Summary

The following are general safety precautions that are not related to any specific procedures. These are recommended precautions that personnel must understand and apply during many phases of operation and maintenance.

Keep Away From Live Circuits

Operating personnel must at all times observe all safety regulations. Do not replace components or make adjustments inside the equipment with the high voltage supply turned on. Under certain conditions, dangerous potentials may exist when the power control is in the off position. To avoid casualties, always remove power, red tag machine and ground a circuit before touching it.

Do Not Service or Adjust Alone

Under no circumstances should any person reach into or enter the enclosure for the purpose of servicing or adjusting the equipment except in the presence of someone who is capable of rendering aid.

Resuscitation

Personnel working with or near high voltages should be familiar with modern methods of resuscitation. Such information may be obtained from the Bureau of Medicine and Surgery.

INSINGER MACHINE COMPANY LIMITED WARRANTY

Insinger Machine Company, Inc. (Insinger) hereby warrants to the original retail purchaser of this Insinger Machine Company, Inc. product, that if it is assembled and operated in accordance with the printed instructions accompanying it, then for a period of either 15 months from the date of shipment from Insinger or 1 year (12 months) from the date of installation or start-up that said Insinger product shall be free from defects in material and workmanship. Whichever one of the two aforesaid limited warranty time periods is the shortest shall be the applicable limited warranty coverage time period.

Insinger may require reasonable proof of your date of purchase; therefore, you should retain your copy of invoice or shipping document.

This limited warranty shall be limited to the repair or replacement of parts which prove defective under normal use and service and which on examination shall indicate, to Insinger's satisfaction, they are defective. Any part that is claimed to be defective and covered by this limited warranty must be returned to Insinger. An RMA# must be obtained from the Insinger Warranty Department before returning any material. Return may be done through an Authorized Service Agency. Furnish serial number of machine and RMA # with shipment and send to:

Insinger Machine Company
6245 State Road
Philadelphia, PA 19135-2996

If Insinger's inspection confirms the defect and the claim, Insinger will repair or replace such part without charge and return it to you freight or postage prepaid.

This limited warranty does not cover any failure or accident, abuse, misuse, alteration, misapplication, improper installation, fire, flood, acts of God or improper maintenance or service,

or failure to perform normal and routine maintenance as set out in the instruction booklet (operating instructions) or for improper operation or failure to follow normal operating instructions (as set out in the instruction booklet). Insinger is not responsible nor liable for any conditions of erosion or corrosion caused by corrosive detergents, acids, lye or other chemicals used in the washing and or cleaning process.

Service must be done by either Insinger Appointed Service Agencies or agencies receiving prior authorization from Insinger.

All warranty work must be done during normal working hours, unless purchaser receives prior authorization from Insinger.

There are no other express warrants except as set forth herein and any applicable implied warranties of merchantability and fitness are limited in duration to the period of coverage of this express written limited warranty. This limited warranty supersedes all other express warranties, implied warranties of merchant-ability and fitness or limited warranties as of this date, January 1, 1998. Some states do not allow limitation on how long an implied warranty lasts so this limitation may not apply to you.

Insinger is not liable for any special, indirect or consequential damages. Some states do not allow the exclusion or limitation of incidental or consequential damages, so this limitation nor exclusion may not apply to you.

Insinger does not authorize any person or company to assume for it any other obligation or liability in connection with the sale, installation, use, removal, return or replacement of its equipment: and no such representations are binding on Insinger.

INSINGER MACHINE COMPANY LIMITED WARRANTY- COMMERCIAL MARINE USE

Insinger Machine Company, Inc. (Insinger) hereby warrants to the original retail purchaser of this Insinger Machine Company, Inc. product, that if it is assembled and operated in accordance with the printed instructions accompanying it (installation manual), then for a period of 15 months from the date of installation on board the vessel, that said Insinger product shall be free from defects in material and workmanship.

Insinger may require reasonable proof of your date of equipment install, therefore, you should retain your copy of invoice or shipping document.

This limited warranty shall be limited to the replacement of parts which prove defective under normal use and service and which on examination shall indicate, to Insinger's satisfaction, they are defective. Any part that is claimed to be defective and covered by this limited warranty must be returned to Insinger. Furnish serial number of machine with shipment and send to:

Insinger Machine Company, Inc.
6245 State Road
Philadelphia, PA 19135-2996

If Insinger's inspection confirms the defect and the claim, Insinger will repair or replace such part without charge and return it to you freight or postage prepaid. If part damages are not covered, Insinger will contact the customer and advise.

If a factory trained authorized technician is required to repair or replace defective parts or material during the 18 month warranty period, the cruise line will be responsible for the payment of travel expense and a minimum of four hours labor.

Labor will be billed to the customer at a reduced rate of \$40.00 per hour. If sailing with a vessel is required, then an eight hour per day minimum will apply.

This limited warranty does not cover accident, abuse, misuse, alteration, misapplication, improper installation, fire, flood, or improper maintenance or service, or failure to perform normal and routine maintenance as set out in the instruction booklet (operating instructions) or for improper operation or failure to follow normal operating instructions (as set out in the instruction booklet).

Insinger is not responsible nor liable for any conditions of erosion or corrosion caused by corrosive detergents, acids, lye or other chemicals used in the washing, caring and or cleaning process.

Warranty service must be done by either Insinger Appointed Service Agencies or agencies, customers galley engineers receiving prior authorization from Insinger.

There are no other express warrants except as set forth herein and any applicable implied warranties of merchantability and fitness are limited in duration to the period of coverage of this express written limited warranty. This limited warranty supersedes all other express warranties, implied warranties of merchantability and fitness or limited warranties as the above date.

Insinger does not authorize any person or company locally or overseas to assume for it any other obligation or liability in connection with the sale, installation, use, removal, return or replacement of its equipment; and no such representations are binding on Insinger.

INSTALLATION INSTRUCTIONS
Commander 18-6 Series & CS Series
Placement

Carefully uncrate machine. Take caution not to damage components which may be mounted on the top or sides of the machine. Set unit in place and adjust the feet to level the machine.

Fasten the tables to the load and unload side of the machine. Most installations require fastening the turn-down lip of the dish tables to the side of the machine with flathead countersunk screws. The table design should provide horizontal clearance of 30" for servicing.

Electrical Connections

Connect electrical lines sized for the correct voltage, current and phase of the machine. These should agree with the machine requirements indicated on the nameplate and labels on the control panel.

A single-point electrical connection is provided for the pumps, control circuit, and wash tank heater.

If an electric booster is provided, connect power directly to the booster.

If the Insinger Self-Contained booster is provided the machine comes standard with a Single-Point Connection (to include the booster).

CAUTION:

Connections must be made to a circuit breaker or fused disconnect as provided by the end-user and required by local codes.

A laminated wiring diagram is inside the control panel.

Fuse Sizing Chart

Model	208VAC/3PH	240VAC/3PH	380VAC/3PH	480VAC/3PH	220VAC/1PH
18-6 (C) Steam heat	10A	10A	6A	6A	15A
18-6 (C) Electric heat	20A	20A	10A	10A	35A
18-6 (C) Electric heat Insinger SCB	60A	50A	30A	25A	90A
18-6H (C) Steam heat	10A	10A	10A	6A	20A
18-6H (C) Electric heat	25A	25A	15A	15A	40A
18-6H (C) Electric heat Insinger SCB	60A	60A	35A	30A	100A

CAUTION:

As with any 3 phase system, an electrician must check all motors for proper phasing, i.e., Pump motors must be running in direction indicated by arrow on housing.

Mechanical Connections

Connect hot water (see specific unit info) lines for tank fill/booster as tagged and noted on the installation drawings. If machine is provided with steam heat connect the steam lines and steam condensate lines as tagged and noted on installation drawings. Connect the drain line.

CAUTION:

Drain lines must be as specified on installation drawings.

Drain line should be properly vented and should have fall of not less than 1/4" to the foot of proper flow.
Some area plumbing codes require drains to flow into an open gap with an opening twice the diameter of the pipe.

Check with your local plumbing codes for the type of drain connection required.

CAUTION:

All lines must be flushed prior to use to remove debris.

CAUTION:

Do not reduce the size of lines as specified in installation drawings. All Lines are sized to facilitate necessary flows, pressures, etc.

HVAC

Ventilation system must be sized to provide adequate ventilation per machine specs. Refer to spec sheet.

Chemicals

Upon the completed installation of the dishwasher, contact a local detergent/chemical supplier for the correct chemicals for your soil load and geographical area.

Electrical connection points for the detergent dispenser and rinse injector are located inside the control panel. Refer to the wiring diagram for this machine for the proper connection points.

Dispensers may be connected on either the primary voltage side of the machine or the 24VAC control voltage side.

CAUTION:

When connecting on the 24VAC control voltage side of the transformer, total VA must not exceed 50VA.

The detergent density probe should be installed in the hole provided & labeled in the wash tank. A switch on the control panel labeled "De-lime" is provided for delimiting the machine. When activated, this switch will keep the machine in an indefinite wash cycle. A switch on the control panel labeled "Heavy Cycle" provide an extended 2 minute wash cycle.

Tabling

Load and unload tables should be pitched towards the machine to return excess water into the machine.

Insinger dishmachines are user-friendly, making them easy to operate and maintain. By following the operation procedure and general cleaning procedures your Insinger dishwasher will give you years of trouble free service.

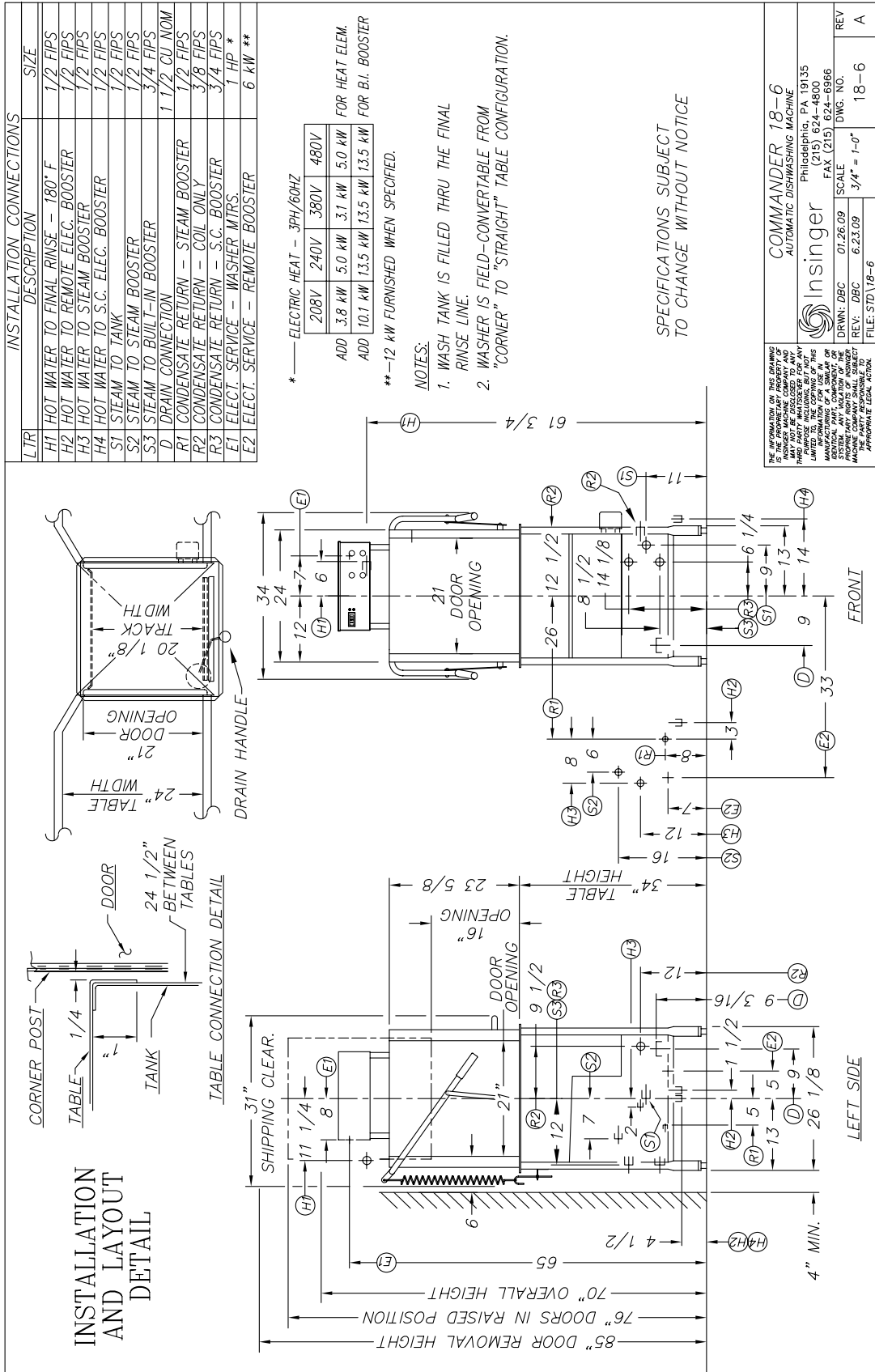

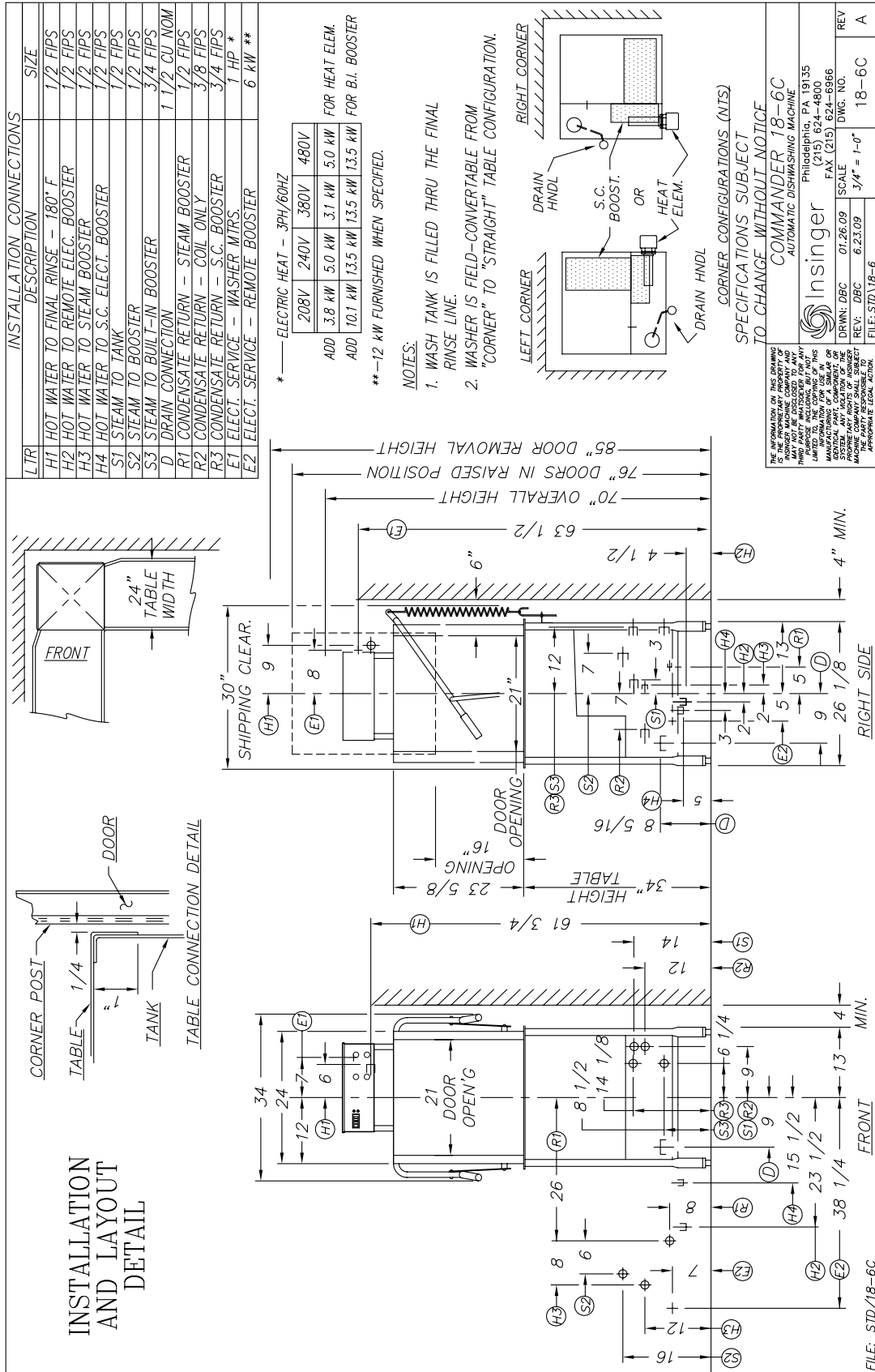

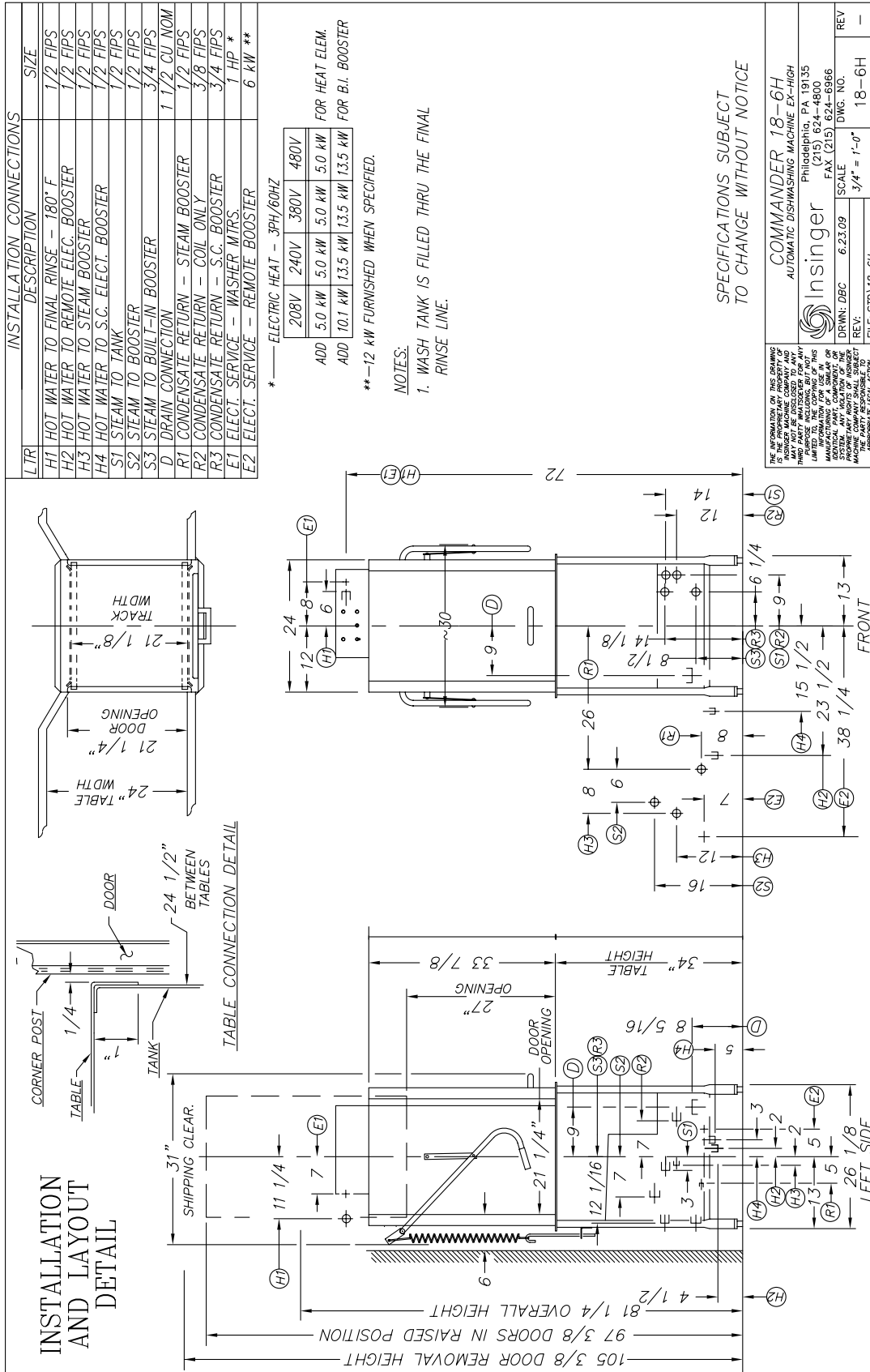

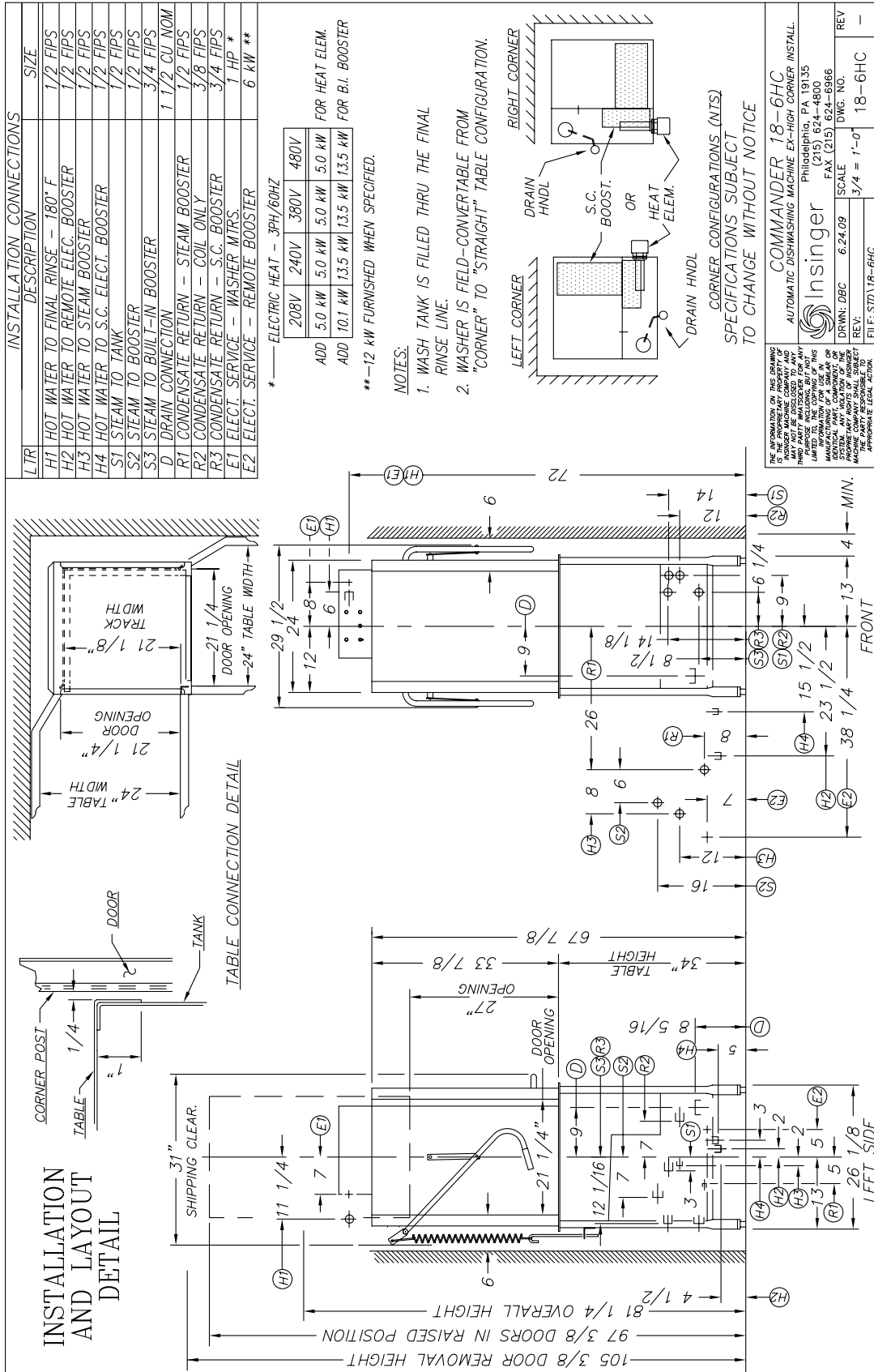

Insinger dishmachines are user-friendly, making them the easiest dishmachines on the market to operate and maintain.

By following these operating procedures your Insinger dishwasher will give you years of trouble free service.

OPERATION INSTRUCTIONS

1. Ensure drain overflow tube is in place. Close all tank drain valve.
2. Check for proper installation and cleanliness of all internal, removable components such as suction strainers, scrap screens, and spray manifolds.
3. Ensure all water & steam lines are open. Ensure electrical circuits are on.
4. Close machine doors.
5. Press the power switch to the ON position. The switch will light up red when on. The machine will fill the tank, run through a complete wash/rinse cycle and shut-off.
6. When the tank is full the tank heat will operate automatically. Proper wash tank temperature is 160° F minimum. Proper final rinse temperature is 180° F minimum at 20 PSI ± SPSI, while in the final rinse cycle.

CAUTION:

To ensure proper operation of the auto tank fill feature and the tank heaters, the tank level floats **MUST** be cleaned daily.

7. Open doors.
8. Insert a rack of soiled dishware in machine and lower doors. The machine is equipped with RackAware™ and will start the wash and rinse automatically. When the rinse indicator light goes off the machine cycle is complete.

CAUTION:

Overloading racks will minimize the proper cleaning of ware.



WARNING:

Do not open the doors during the wash/rinse cycle as hot water is being sprayed. An interlock is provided to stop the wash/rinse cycle if the doors are opened but hot water may spray out if doors are opened too quickly.

9. Open doors and remove rack of clean ware. For continuous operation repeat steps 7 & 8.
10. Upon completion of ware cleaning press the power switch to the "OFF" position. The switch light will go off.
11. Refer to the cleaning procedures for proper clean-up of the dishmachine.
12. A switch on the control panel labeled "De-lime" is provided for use when de-liming the machine. When activated, this switch will keep the machine in an indefinite wash cycle.
13. A switch on the control panel labeled "Heavy Cycle" will activate the extended wash cycle for heavily soiled ware.
14. Report any unusual occurrences to qualified service personnel.

The following cleaning procedures should be done daily, at the end of the shift.

Cleaning Procedures, Daily

1. Remove all internal removable parts including spray manifolds, scrap screens, drain overflow tube and suction strainer.
2. Remove the end caps from the spray manifolds and clean with the brush provided. Flush the manifolds.
3. Flush scrap screens
4. Clean drain overflow tube.



NOTE:

V-cup seal on the drain overflow tube may become gummed not allowing the overflow tube to seal. This will cause the drain to leak water. Remove any build-up on the V-cup seal. When the seal becomes worn, replace with part #D2-557.

CLEANING PROCEDURES (continued)

5. Clean suction strainers of build-up.

NOTE:

Improper cleaning of the suction strainers will cause the pumps to cavitate. This will cause poor washing results.

6. Clean the tank level float with a plastic abrasive pad (do not use steel wool).

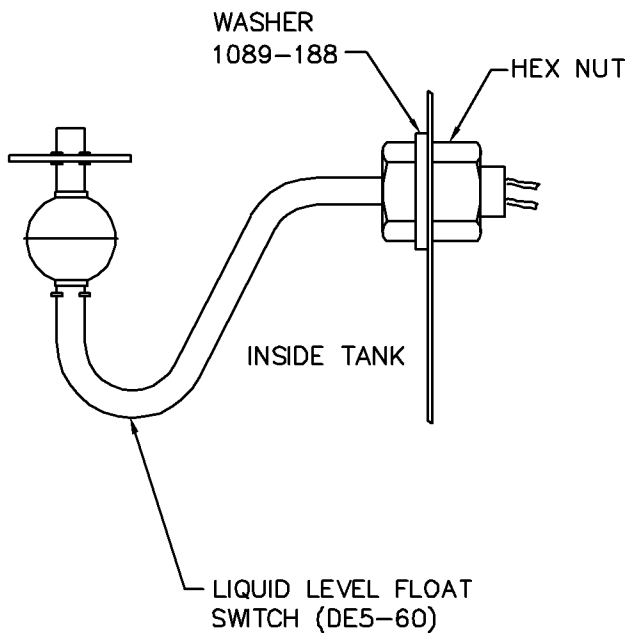
CAUTION:

Level floats must be cleaned daily. Build-up of grease and dirt will cause faulty operation of the tank fill heating system.

NOTE:

Upper and lower wash & rinse pipes are not the same.

7. Final rinse nozzles should be cleaned of matter clogging the jet spray.

8. The doors should be left open to allow drying of interior surfaces.

PRESSURE ADJUSTMENT

Pressure in the final rinse must be maintained at 20 ± 2 psi. Adjustment of the pressure is made with the adjusting screw on the pressure reducing valve.

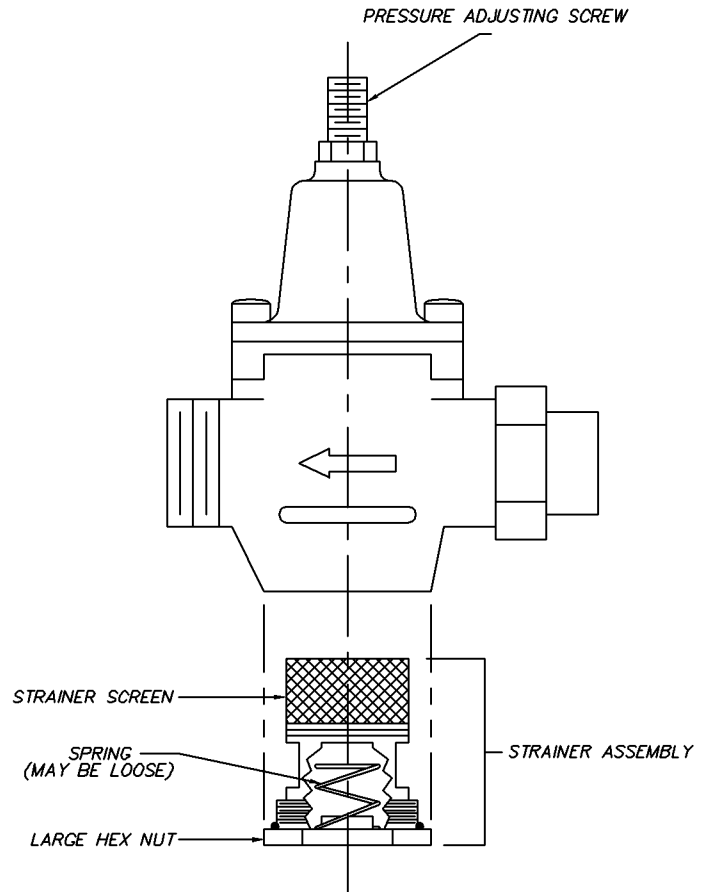

SKETCHA\SK-4689 PRESSURE REDUCING VALVE

If there are flow or pressure problems with the pressure reducing valve, CAREFULLY remove the strainer assembly and clean the strainer screen. Be careful not to damage the Hex nut o-ring

NOTE:

The pressure reducing valve is supplied only on units equipped with optional booster

The following is a basic guide for the repair and replacement of common dishwasher parts. Refer to the Basic Services Guide for troubleshooting tips.

MAINTENANCE REQUIREMENTS

Daily

1. Refer to the operations and cleaning instructions provided in this manual for daily cleaning procedures.

Weekly

1. The entire machine should be wiped down using an industrial grade stainless steel cleaner.
2. Under the supervision of your detergent supplier the machine interior must be properly de-limed.



NOTE:

The water quality in some areas requires de-liming to be done more frequently. Contact your detergent supplier for recommended de-liming frequency.

Quarterly

1. Remove and clean the strainer screens on the water and steam lines. If the screens cannot be cleaned, replace.
2. Inspect the condition of the solenoid valve seats, and diaphragms. Replace where necessary.
3. Inspect drain O-Rings for leakage. Replace where necessary.
4. Check door spring tension and adjust where necessary.
5. Check wash and rinse hub bushing/bearing and replace where necessary.

MAINTENANCE PROCEDURES

Solenoid Valve Disassembly

(See dwg. SK-4692)

1. Disconnect the power supply to the machine. Turn off the water supply.
2. Remove cap on top of the coil. Remove the coil.
3. Remove the 4 hex bolts and lift bonnet from valve body. Note positioning of spring and plunger.
4. Remove main piston.

5. Inspect for dirt, wear or lime build-up. Clean or replace as required.
6. Reassemble in reverse of disassembly.

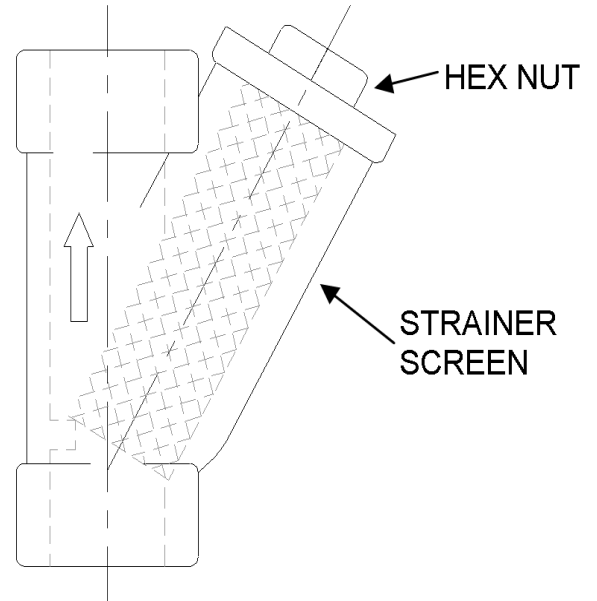

Liner Strainer Disassembly

1. Shut off water or steam supply.
2. Remove large hex nut on bottom of strainer body.
3. Remove strainer screen. Inspect and clean or replace as necessary.
4. Reassemble in reverse of disassembly. Water flow must be same direction as arrow on line strainer body. Use new gaskets to insure a tight seal.



NOTE:

Supplied only on units without optional boosters.

Pump Disassembly

1. Before disassembling pump ensure there are no obstructions in the pump intake. Remove and clean the suction strainer (inside tank). See dwg. SK-2456 & SK-2923



NOTE:

It is not necessary to remove the pump housing from the machine to disassemble.

Pump Disassembly (Continued)

1. Remove the pump motor and impeller by removing the 4 hex bolts attaching them to the pump housing.
2. Repair or replace the pump parts as required.
3. Reassemble in reverse of disassembly.

Immersion Heater Replacement

See dwg. #SK-4703

1. The immersion heater **MUST** be completely submerged at all times. If this is not the case contact a qualified service technician. The heated surface should never be in contact with sludge. See dwg. SK-4703.
2. Remove the housing covering the wiring terminations. Disconnect the immersion heater wires.
3. Remove the immersion heater by loosening and removing the large hex nut.
4. The taper side of the nut must face toward wall of tank.
5. Remount Hi-Temp cutoff switch to top heavy element. (See dwg. #1433-3).



NOTE:
Use plumbers putty as gasketing around the immersion heater to minimize leaks.

Tank Heat Temperature Adjustment

1. A temperature control board is provided in the control panel for easy adjustment of tank temperature. Though tank temperature is adjusted during the machines factory test it is sometimes necessary to re-adjust the temperature at start-up.
2. Locate the temperature control board. Use the control panel layout drawing located in Section 4, Electrical Schematic and Replacement Parts.
3. Adjust the tank temperature to the desired temperature by turning the potentiometer located on the temperature control board. An arrow on the potentiometer indicates increase.
4. If the temperature does not change refer to Troubleshooting Tank Temperatures in the next section.

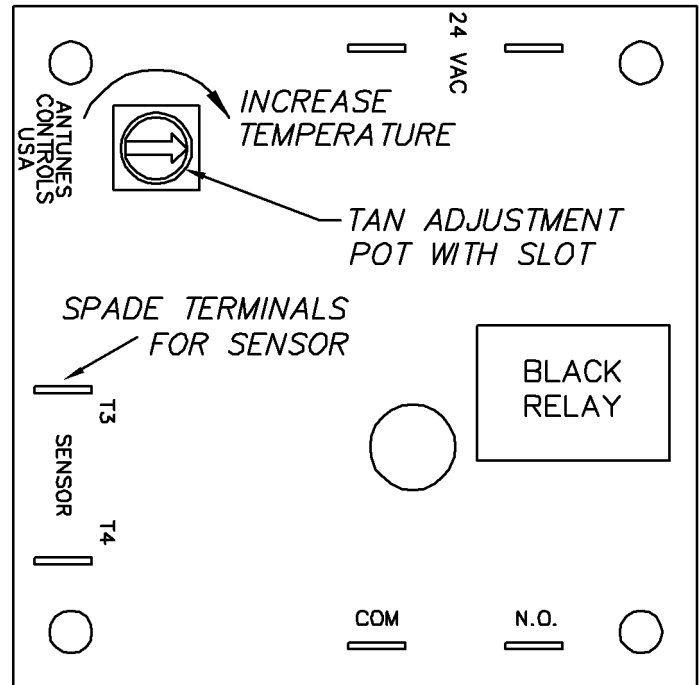

TANK TEMPERATURE CONTROL BOARD
(DE9-251)

Troubleshooting Tank Temperatures
Electric Heat

1. If temperature does not change check the temperature control board (P/N DE9-251) proper operation. If the temperature control board is faulty, replace.
2. Verify tank heat contactor is working correctly. If not, replace.
3. Verify all immersion heaters are working properly and not limed. If not, replace.

Steam Heat

1. If temperature does not change check the temperature control board (P/N DE9-251) proper operation. If the temperature control board is faulty, replace.
2. Verify steam pressure per machine specifications.
3. Verify steam trap is not clogged. If so, replace.

Motor Overloads

All motors used on Insinger Machines are provided with motor overloads. Motor overloads are adjusted when the machines are factory tested. Should it be necessary to adjust the motor overloads in the field first verify the motor current draw for the voltage the machine is using.

Using the Control Panel Component Layout Dwg. located in Section 3 to identify the overload adjust by turning the dial to the appropriate AMP draw.

When changing a motor always check OK setting against name plate FLA.

Level System

The level control system consists of one overflow timer (P/N DE7-35) and one level float (P/N DEF-60) per tank.

When the system is powered-up, the tank(s) will begin to fill (assuming no water is in the tanks).

When the level float is actuated, the overflow timer begins to time-out and continues the filling process until the tank(s) is full.

Also consists of a Hi-Limit switch in electric heated unit. Hi-Limit in series with float. Inspect Hi-Limit for damage. Be careful when cleaning not to damage it.

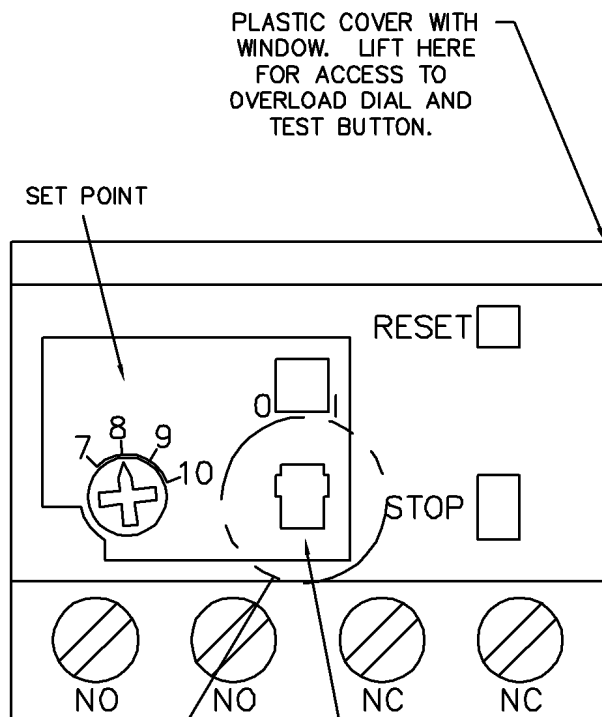

PLASTIC COVER WITH WINDOW. LIFT HERE FOR ACCESS TO OVERLOAD DIAL AND TEST BUTTON.

SET POINT

RESET

STOP

NO

NO

NC

NC

RESET SELECTOR WINDOW (AUTO RESET MODE SHOWN)

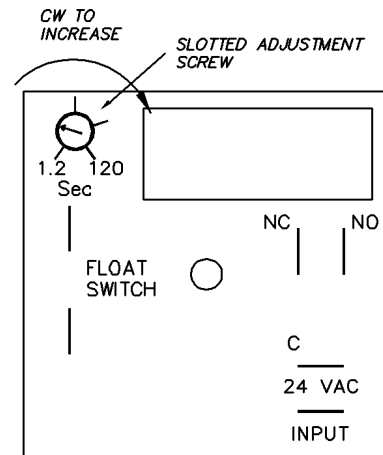

Liquid Level Timer DE7-35
Sk-4698



NOTE:

The overflow timer **MUST** be adjusted during initial start-up. Adjustment depends on water fill pressure. The water level **MUST** be 1/4" below the lip of the overflow tube. Adjust by increasing or decreasing the potentiometer on the level timer.



NOTE:

Dirty level floats will cause the tank heat to energize with no water in the tanks. **LEVEL FLOATS MUST BE CLEANED DAILY.**

TO CHANGE FROM MANUAL TO AUTO RESET:

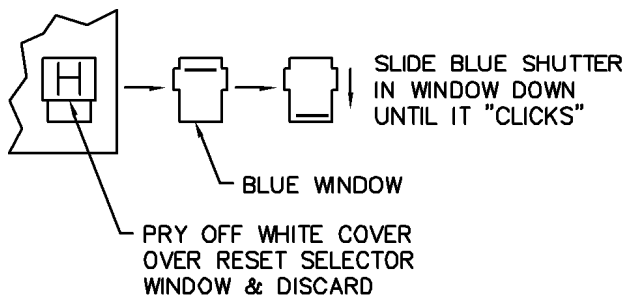

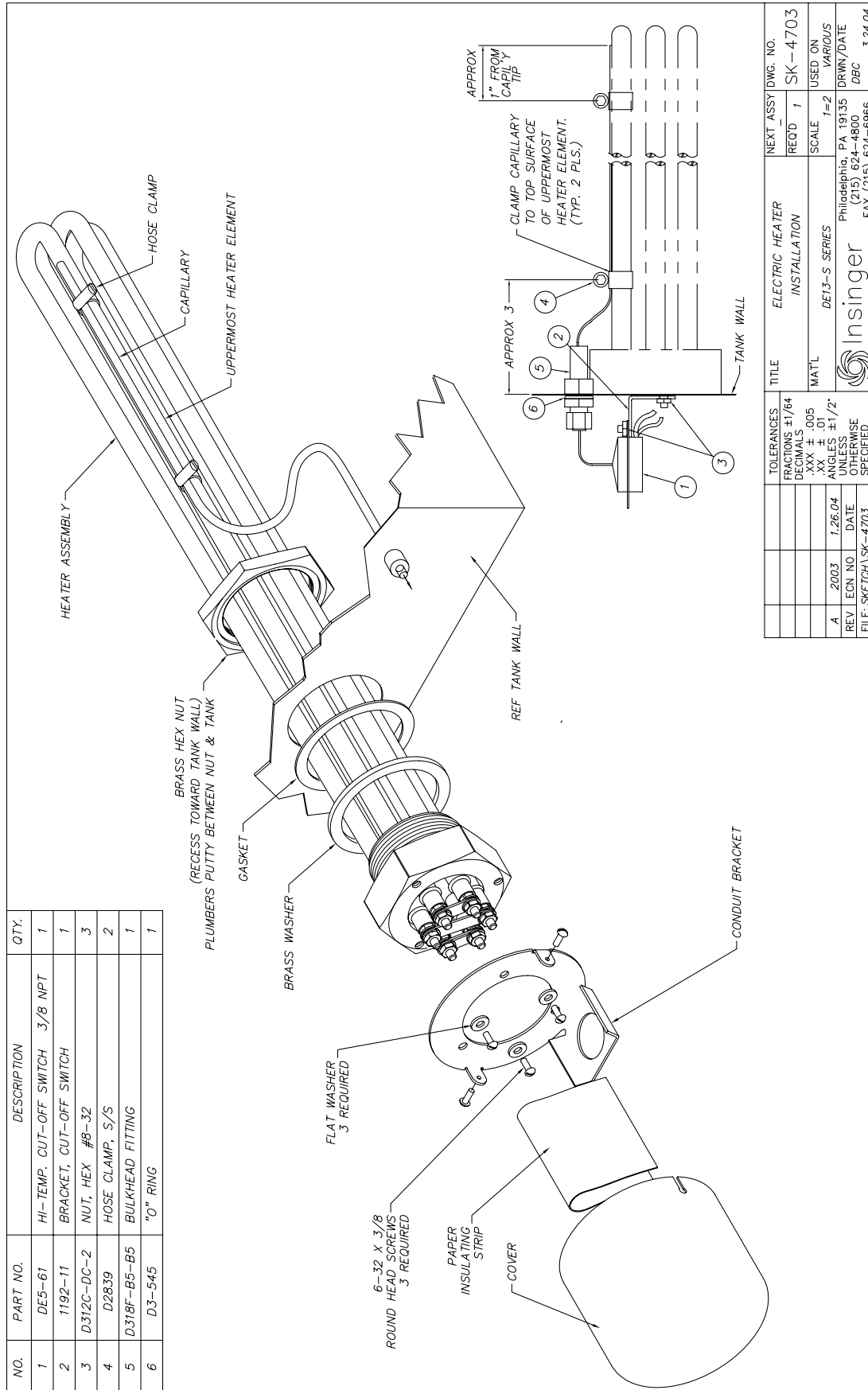

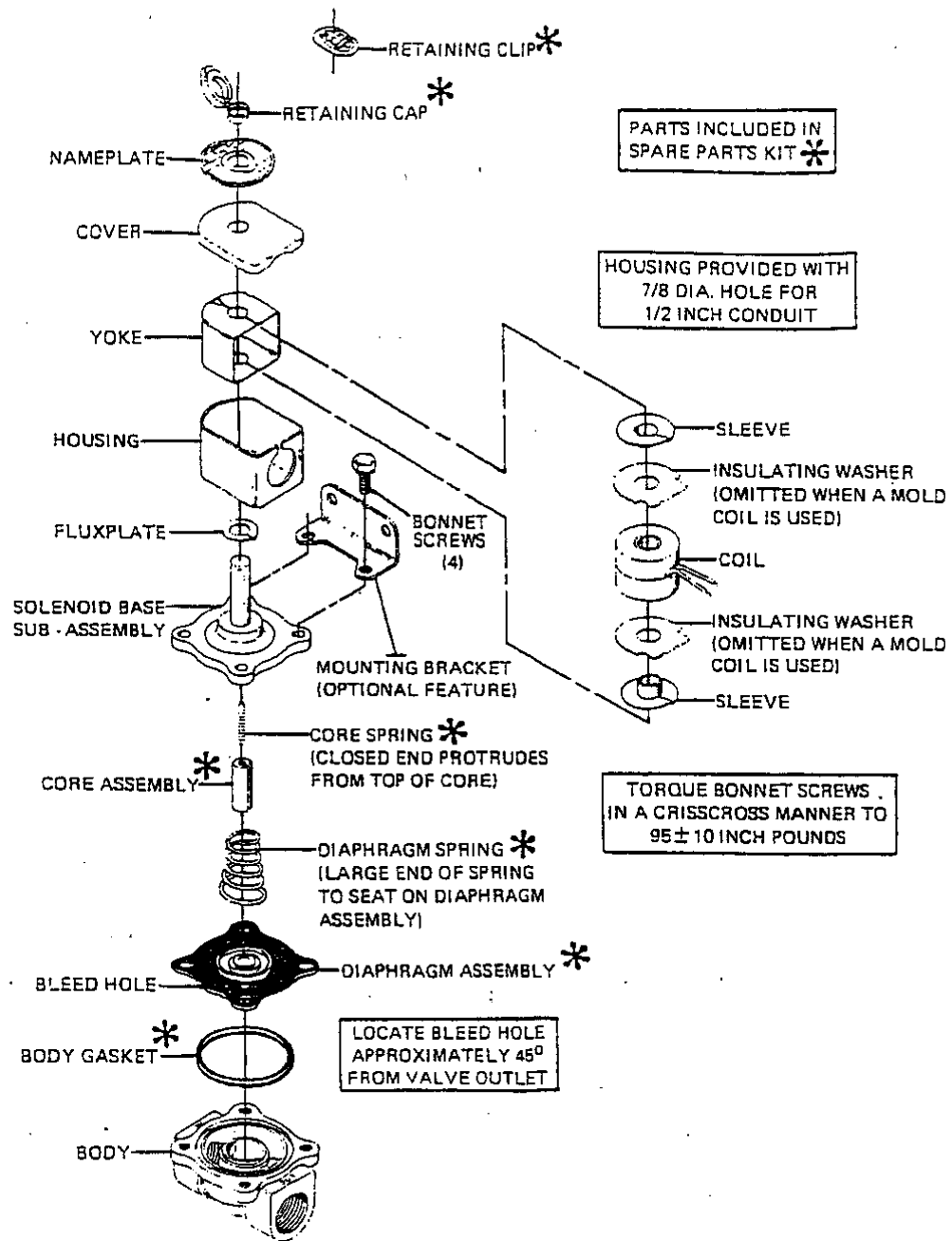

SOLENOID VALVE
FINAL RINSE
6-17

SKETCHA\SK-4692

ITEM	PART NO.	DESCRIPTION	QTY.
1	D2468-JF3D-2BW	MOTOR 2 H.P.	1
2	D431	ADAPTER	1
3	D443	IMPELLER 4 3/8"	1
4	D434	CASING	1
5	D2-532	"O" RING	1
6	D2-533	FLINGER	1
7	D2-534	SEAL ASSEMBLY	1
8	D329-5	DRAIN PETCOCK 1/4 IPS	1
9	D3-808	IMPELLER RETAINING NUT	1

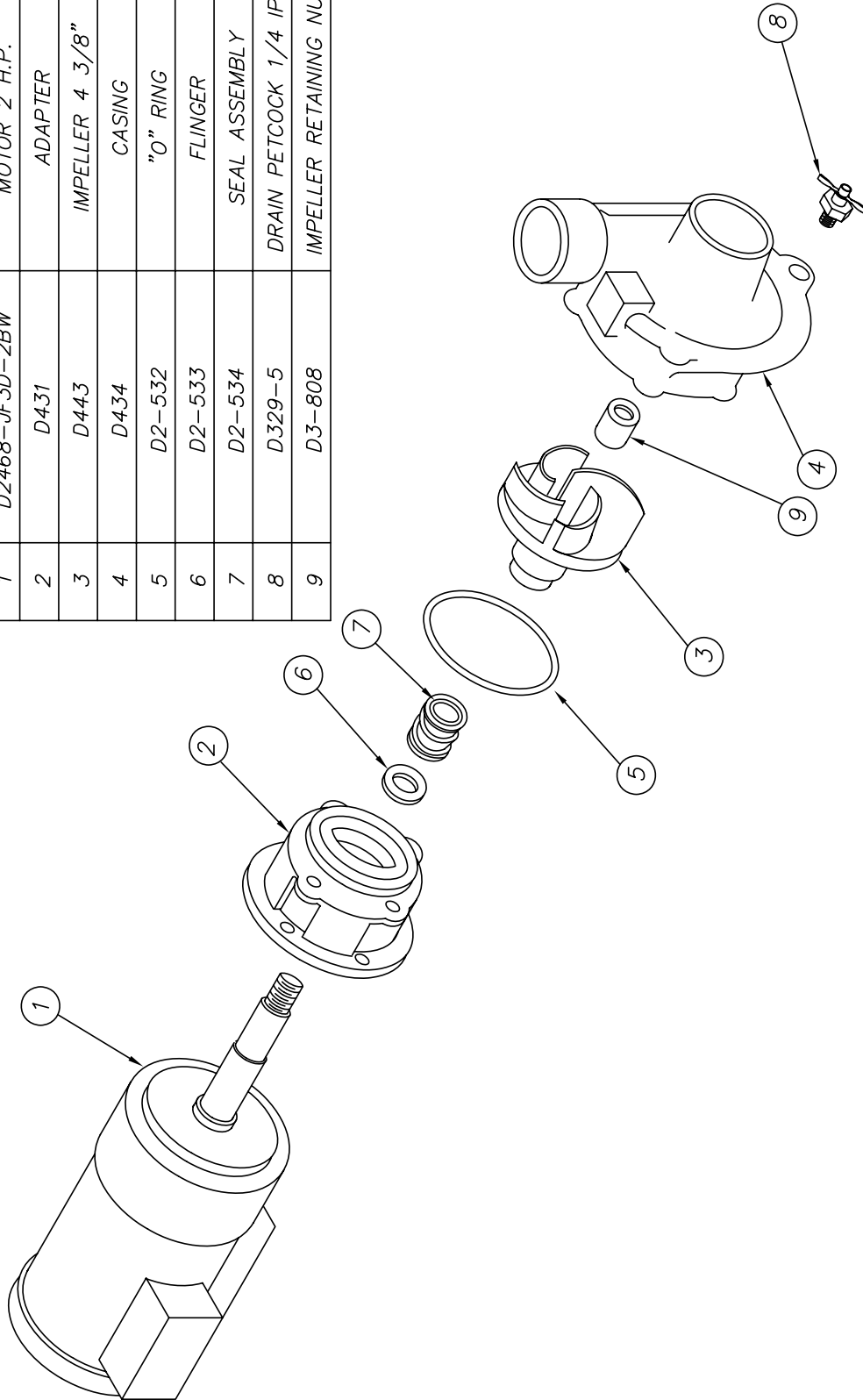

TOLERANCES		TITLE	PARTS LIST	NEXT ASSY DWG. NO.
FRACTIONS	±1/64			
DECIMALS	.XXX ± .005	MAT'L	SCALE	VARIOUS
.XX ± .01	ANGLES ±1/2°	Philadelphia, PA 19135 (215) 624-4800 FAX (215) 624-6966		
UNLESS OTHERWISE SPECIFIED	FILE: SKETCHA \ SK-2923	DRWN/DATE MAM 11.11.93		

ITEM	PART NO.	DESCRIPTION	QTY.
1		MOTOR 1 H.P.	1
2	D431	ADAPTER	1
3	D436	IMPELLER 3 7/8"	1
4	D434	CASING	1
5	D2-532	"O" RING	1
6	D2-533	FLINGER	1
7	D2-534	SEAL ASSEMBLY	1
8	D329-5	DRAIN PETCOCK 1/4 IPS	1
9	D3-808	IMPELLER RETAINING NUT	1

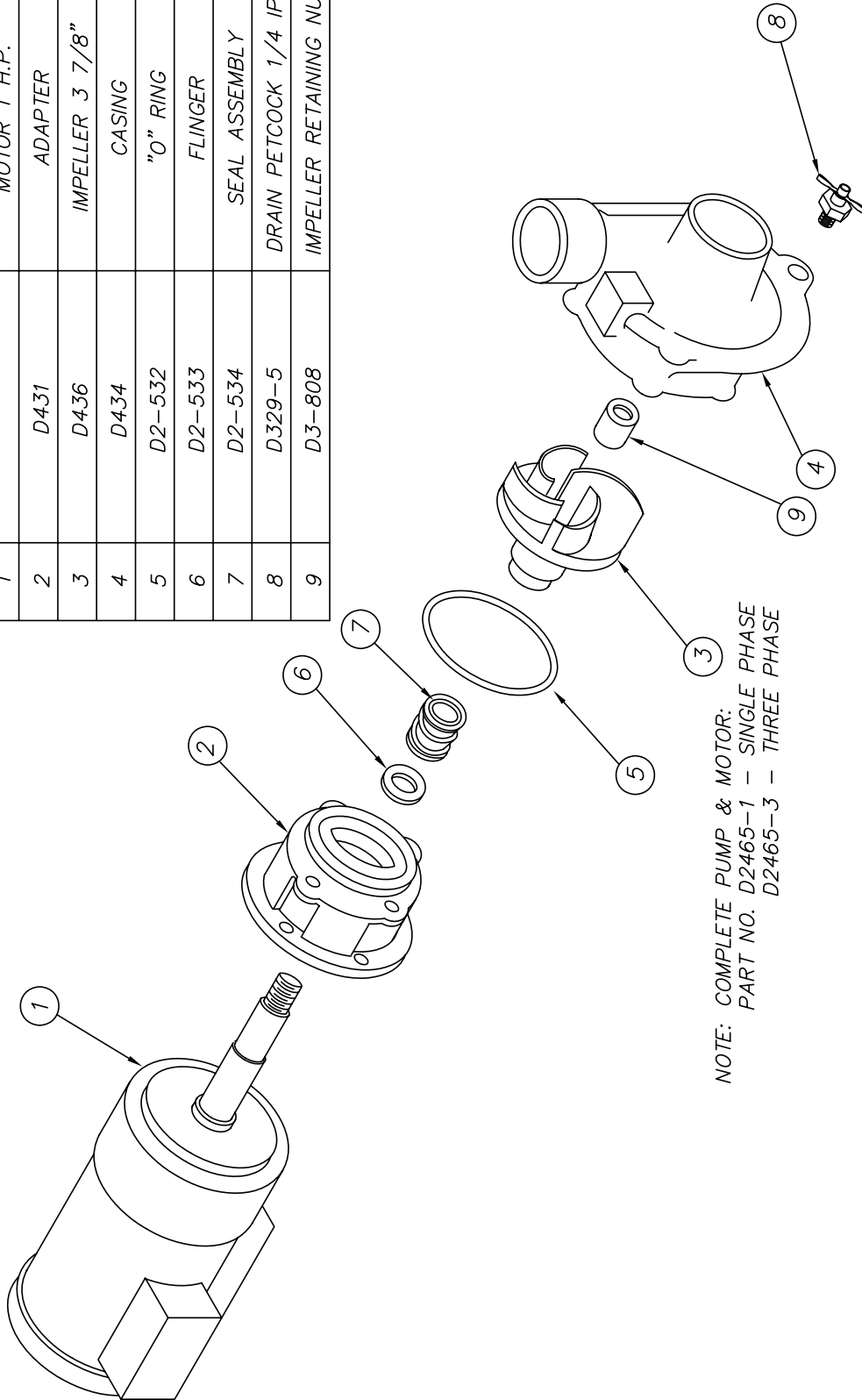

NOTE: COMPLETE PUMP & MOTOR:
PART NO. D2465-1 - SINGLE PHASE
D2465-3 - THREE PHASE

TOLERANCES		TITLE		NEXT ASSY DWG. NO.	
FRACTIONS	±1/64	PARTS LIST		REQ'D	SK-2462
DECIMALS	.XXX ± .005	1 HP PUMP		SCALE	USED ON
.XX ± .01		MAT'L	-		VARIOUS
ANGLES	±1/2°	Insinger			DRWN/DATE
UNLESS OTHERWISE SPECIFIED		Philadelphia, PA 19135			MAM
		(215) 624-4800			11.11.93
REV	ECN NO	FAX (215) 624-6966			
FILE: SKETCHA \ SK-2462	DATE				

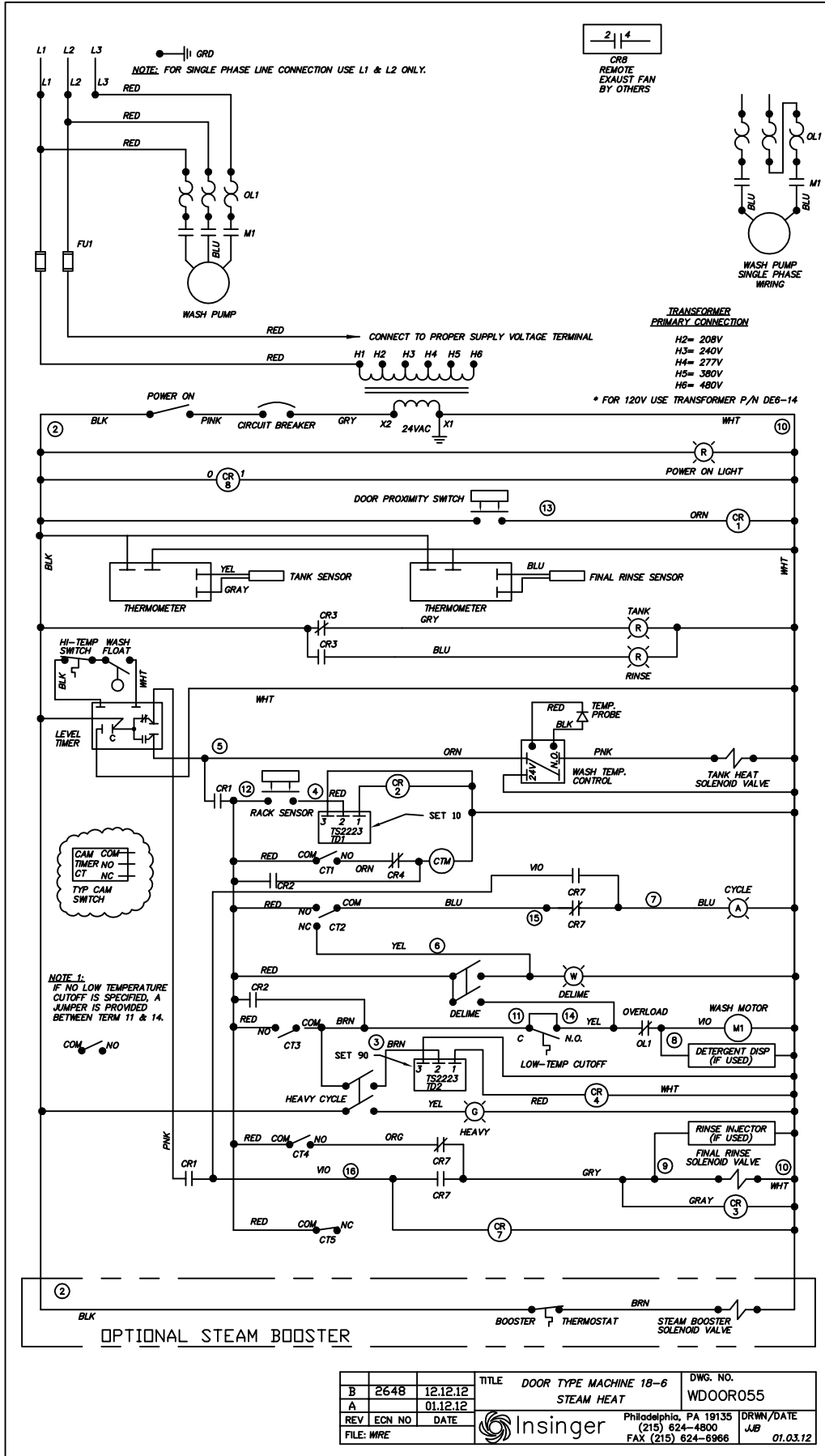

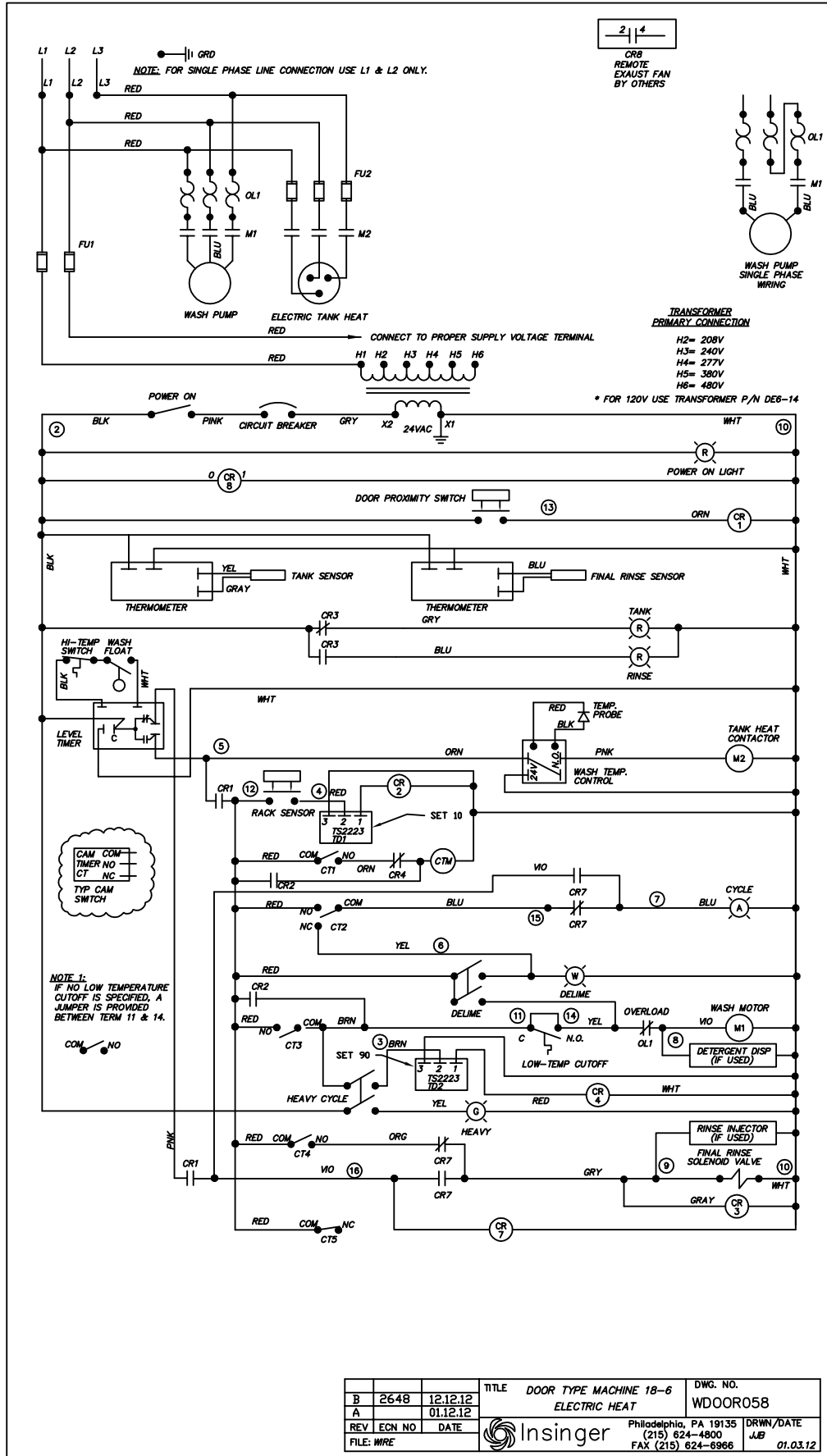

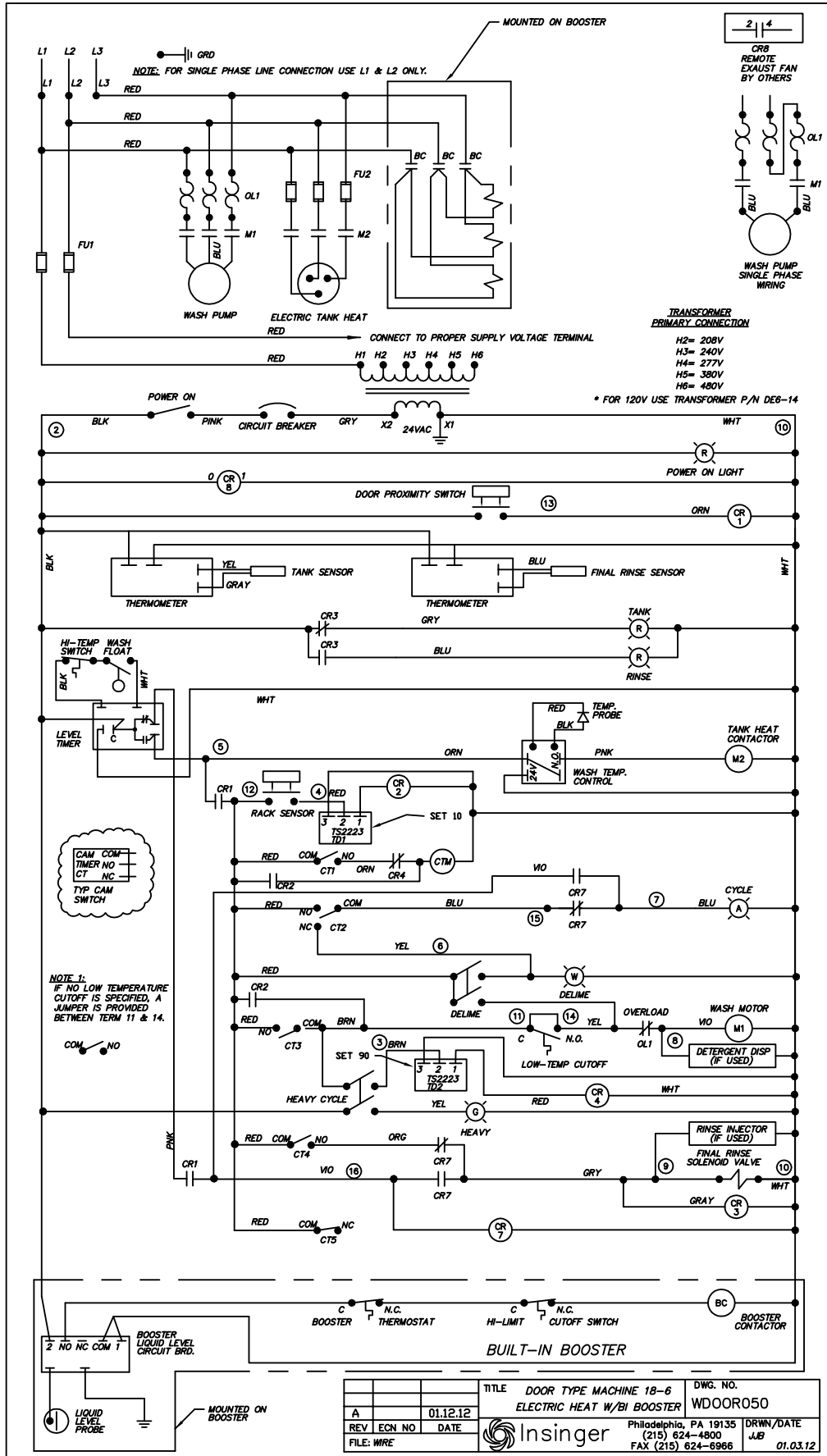

ITEM	DESCRIPTION	PART NO.	QTY	ITEM	DESCRIPTION	PART NO.	QTY	ITEM	DESCRIPTION	PART NO.	QTY
12	DIN RAIL (35 mm)	DE9-84	1	8	TIMER	DE7-12	2	1	COMPONENT MTG PLATE (13.5 x 12.69)	SK-3749	1
13	DIN RAIL (15 mm)	DE3-42	1	8A	POTENTIOMETER FOR DE7-12	DEB-43	2	2	TRANSFORMER (100 VA, 24 VAC)	DEB-6	1
14	TERMINAL SECTION	DE3-39	14	9	STANDARD UNIT	DE2-37	5	5	ALL VOLTAGES EXCEPT 120 V	DEB-14	1
15	TERMINAL END COVER PLATE	DE3-40	1	9	RELAY BASE	DE3-43	5	5	FUSE BLOCK KIT (100 VA XFMR) FOR DEB-6	DE9-163	2
16	TERMINAL END CLAMP	DE9-251	2	10	RELAY	DE2-37	6	6	FUSE (100 VA TRANSFORMER PRIMARY)	DE9-191	1
17	TEMPERATURE CONTROL BOARD	DE7-42	1	11	RELAY HOLD DOWN SPRING	DE2-38	6	6	FUSE (100 VA TRANSFORMER PRIMARY)	DE9-166	2
18	CAM TIMER STD UNIT 5 CAMS	DE7-42	1	9	VAPORGUARD UNIT	DE3-43	5	5	FUSE (100 VA TRANSFORMER PRIMARY)	DE9-168	1
		DE7-43	1	10	RELAY BASE	DE2-37	6	6	FUSE (100 VA TRANSFORMER PRIMARY)	DE9-200	1
				11	RELAY HOLD DOWN SPRING	DE3-43	6	6	FUSE (100 VA TRANSFORMER PRIMARY)	DE9-201	1
									OVERLOAD RELAY (1 HP PUMP)	DE2-52	1
									OVERLOAD RELAY (2 HP PUMP)	DE2-52	1
									OVERLOAD RELAY (2 HP PUMP)	DE2-53	1
									OVERLOAD RELAY (2 HP PUMP)	DE2-53	1
									OVERLOAD RELAY (2 HP PUMP)	DE2-54	1
									OVERLOAD RELAY (2 HP PUMP)	DE2-55	1
									OVERLOAD RELAY (2 HP PUMP)	DE2-57	1
									OVERLOAD RELAY (2 HP PUMP)	DE2-55	1
									OVERLOAD RELAY (2 HP PUMP)	DE2-61	1
									OVERLOAD RELAY (2 HP PUMP)	DE1-93	1
									OVERLOAD RELAY (2 HP PUMP)	DE1-109	1
									OVERLOAD RELAY (2 HP PUMP)	DE1-110	1
									OVERLOAD RELAY (2 HP PUMP)	DE1-109	1
									OVERLOAD RELAY (2 HP PUMP)	DE1-110	1
									OVERLOAD RELAY (2 HP PUMP)	DE1-111	1

8 7 6 5 4 3 2 1

DESCRIPTION

12 DIN RAIL (35 mm)

13 DIN RAIL (15 mm)

14 TERMINAL SECTION

15 TERMINAL END COVER PLATE

16 TERMINAL END CLAMP

17 TEMPERATURE CONTROL BOARD

18 CAM TIMER STD UNIT 5 CAMS

CAM TIMER 16 UNIT 6 CAMS

1 2 3 4 5 6 7 8

ITEM

8 TIMER

8A POTENTIOMETER FOR DE7-12

9 STANDARD UNIT

9 RELAY BASE

10 RELAY

11 RELAY HOLD DOWN SPRING

9 VAPORGUARD UNIT

9 RELAY BASE

10 RELAY

11 RELAY HOLD DOWN SPRING

38 39 31 32 33

40 41

22

21

2 3 4

9 10 11 13 14 15 16

45 46 47

48

REPLACES 45,46,47 ON NON VAPORGUARD UNITS

8 8A

18

CAM TIMER 5 OR 6 SWITCHES

1 2 3 4 5 6 7 8

DESCRIPTION

8 TIMER

8A POTENTIOMETER FOR DE7-12

9 STANDARD UNIT

9 RELAY BASE

10 RELAY

11 RELAY HOLD DOWN SPRING

9 VAPORGUARD UNIT

9 RELAY BASE

10 RELAY

11 RELAY HOLD DOWN SPRING

38 39 31 32 33

40 41

22

21

2 3 4

9 10 11 13 14 15 16

45 46 47

48

REPLACES 45,46,47 ON NON VAPORGUARD UNITS

8 8A

18

CAM TIMER 5 OR 6 SWITCHES

1 2 3 4 5 6 7 8

DESCRIPTION

8 TIMER

8A POTENTIOMETER FOR DE7-12

9 STANDARD UNIT

9 RELAY BASE

10 RELAY

11 RELAY HOLD DOWN SPRING

9 VAPORGUARD UNIT

9 RELAY BASE

10 RELAY

11 RELAY HOLD DOWN SPRING

38 39 31 32 33

40 41

22

21

2 3 4

9 10 11 13 14 15 16

45 46 47

48

REPLACES 45,46,47 ON NON VAPORGUARD UNITS

8 8A

18

CAM TIMER 5 OR 6 SWITCHES

1 2 3 4 5 6 7 8

DESCRIPTION

8 TIMER

8A POTENTIOMETER FOR DE7-12

9 STANDARD UNIT

9 RELAY BASE

10 RELAY

11 RELAY HOLD DOWN SPRING

9 VAPORGUARD UNIT

9 RELAY BASE

10 RELAY

11 RELAY HOLD DOWN SPRING

THE BUYER IS RESPONSIBLE FOR THE PROPER SELECTION OF THE PARTS TO BE ORDERED. THE BUYER IS RESPONSIBLE FOR THE PROPER SELECTION OF THE PARTS TO BE ORDERED. THE BUYER IS RESPONSIBLE FOR THE PROPER SELECTION OF THE PARTS TO BE ORDERED.

AE	2648	12.12.12	TOLERANCES	CONTROL PANEL LAYOUT	NEXT ASSY	DWG NO.
AD	2644	11.21.12	FRACTIONS #/64	18-6	REQ'D	SK-3490
AC	2551	01.03.12	DECIMALS	FINISH	USED ON	
AB	2364	08.10.09	XXX ± .005	WEIGHT: LBS		
AA	2310	04.02.09	XX ± .01	BLANK SITE :	SCALE:	IRV/DATE
REV	ECN NO	DATE	ANGLES #1/2"	PROGRAM No:	1:4	A.S.
DWG DR	FILE	SKETCH	UNLESS OTHERWISE SPECIFIED			02.22.08
B						REV
						UP
						1
						2

NOTES:

1. A FUSE BLOCK FOR TANK HEATERS (ITEM 38 OR 40) IS USED ONLY WHEN A SELF CONTAINED BOOSTER IS PROVIDED.



Philadelphia, PA 19135
(215) 624-4800
FAX (215) 624-6966

ITEM	DESCRIPTION	PART NO.	QTY	ITEM	DESCRIPTION	PART NO.	QTY	ITEM	DESCRIPTION	PART NO.	QTY
19	DATA DECAL	SK-4973	1	31	GROUNDING STUD, 1/4-20	D309C-GC-4G	1	40	FUSE BLOCK, 2 POLE (W/ 1 PH SCB)	DE9-185	1
20	TIMER (LIQUID LEVEL)	DE7-35	1	32	LOCKWASHER, 1/4"	D313C-G5	1	41	FUSE (W/ 1 PH SCB)	DE9-207	2
21	TERMINAL BLOCK END STANDARD UNITS	DE3-9B	1	33	HEX NUT, 1/4-20	D312C-GC-2	1	42	OVERLOAD BASE	DE2-60	1
	TERMINAL BLOCK SECTION	DE3-9A	3	34	CONTROL BOX 16"	1089-223	1	43	LABEL, WASH TEMPERATURE	SK-4975	1
	VAPORGUARD UNITS	DE3-9A	7	35	CONTROL BOX COVER 16"	1089-193P	1	44	LABEL, FINAL RINSE TEMPERATURE	SK-4976	1
22	TERMINAL BLOCK ASSY	DE3-3	1	36	GASKET	9007-001	1	45	RELAY BASE 5A	DE2-95	1
	208-460 V, 3 PHASE	DE3-3	1	37	NUT	D312C-EF-5	4	46	RELAY 5A	DE2-96	1
	240 SINGLE PHASE	DE3-154	1	38	FUSE BLOCK, 3 POLE (W/ 3 PH SCB)	DE9-186	1	47	RELAY HOLD DOWN SPRING FOR DE2-95	DE3-164	1
	240 SINGLE PHASE W/SCB	DE3-152	1	39	FUSE (W/ 3 PH SCB)		3	48	RELAY REMOTE EXHAUST FAN BY OTHERS	DE9-284	1
	EXTRA HIGH W/SCB	DE3-152	1		460 V	KTK-R-10					
	VAPORGUARD UNITS	DE3-152	1		380 V	KTK-R-10					
23	DECAL- COMMANDER SERIES FRT CNT BOX	SK-4974	1		230 V	KTK-R-15					
24	SWITCH WITH LIGHT RED, (POWER ON)	DE5-84	1		208V	KTK-R-20					
25	SWITCH WITH LIGHT WHITE, (DELINE)	DE5-85	1								
26	SWITCH WITH LIGHT GREEN (HEAVY CYCLE)	DE5-83	1								
27	PILOT LIGHT (AMBER)	DE5-86	1								
28	CIRCUIT BREAKER (5A)	DE9-43	1								
29	INDICATOR LIGHTS RED	DE9-294	2								
30	DIGITAL THERMOSTAT DISPLAY	DE9-295	2								

ITEM	DESCRIPTION	PART NO.	QTY
18-6	QTY	1	1
	KW	5	1
	PART#	DE13-SD23	DE13-SD43
		DE13-SD23	DE13-SD53
18-6C	QTY	1	1
	KW	5	1
	PART#	DE13-SD23	DE13-SD43
		DE13-SD23	DE13-SD53
18-6H	QTY	1	1
	KW	5	1
	PART#	DE13-SD23	DE13-SD43
		DE13-SD23	DE13-SD53
18-6HC	QTY	1	1
	KW	5	1
	PART#	DE13-SD23	DE13-SD43
		DE13-SD23	DE13-SD53

NOT SHOWN

TEMPERATURE SENSOR FOR DE9-251 DE9-252

TEFLON SEAL NUT FOR DE9-252 D337

TEMP SENSOR FOR DIGITAL DISPLAY DE9-295 DE9-296

COMPRESSION FITTING FOR DE9-296 D317F-B2-B5

ELECTRIC IMMERSION HEATER

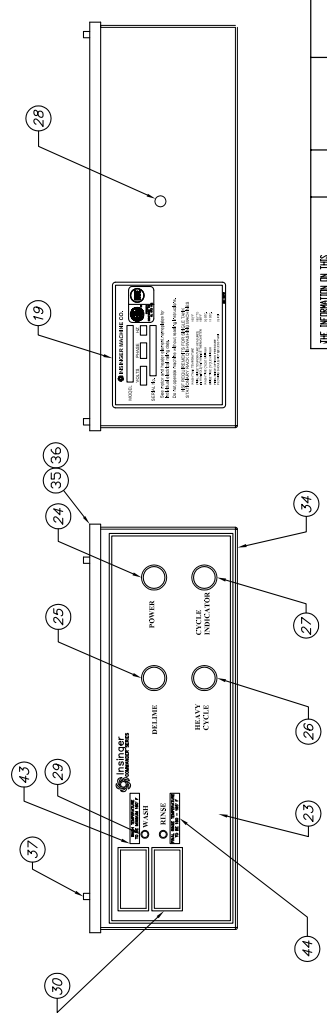

TOLERANCES	FILE: SKETCH	DATE	REV	DATE
AE 2648	12.12.12			
AD 2644	11.21.12			
AC 2551	07.03.12			
AB 2384	08.10.09			
AA 2310	04.02.09			
REV	EON	NO		
DATE	FILE: SKETCH			

TITLE	CONTROL PANEL LAYOUT	18-6	FINISH	USED ON
MAT'L				
WEIGH: LIS				
BLANK SITE				
PROGRAM No:				
SCALE:	1:4			
DRW/DATE				
A.S.				
REV				
SHEET	2			
AE				

REV	DATE	BY	CHK	APP
1				
2				

Philadelphia, PA 19125
 (215) 624-4800
 FAX (215) 624-6966

Insinger

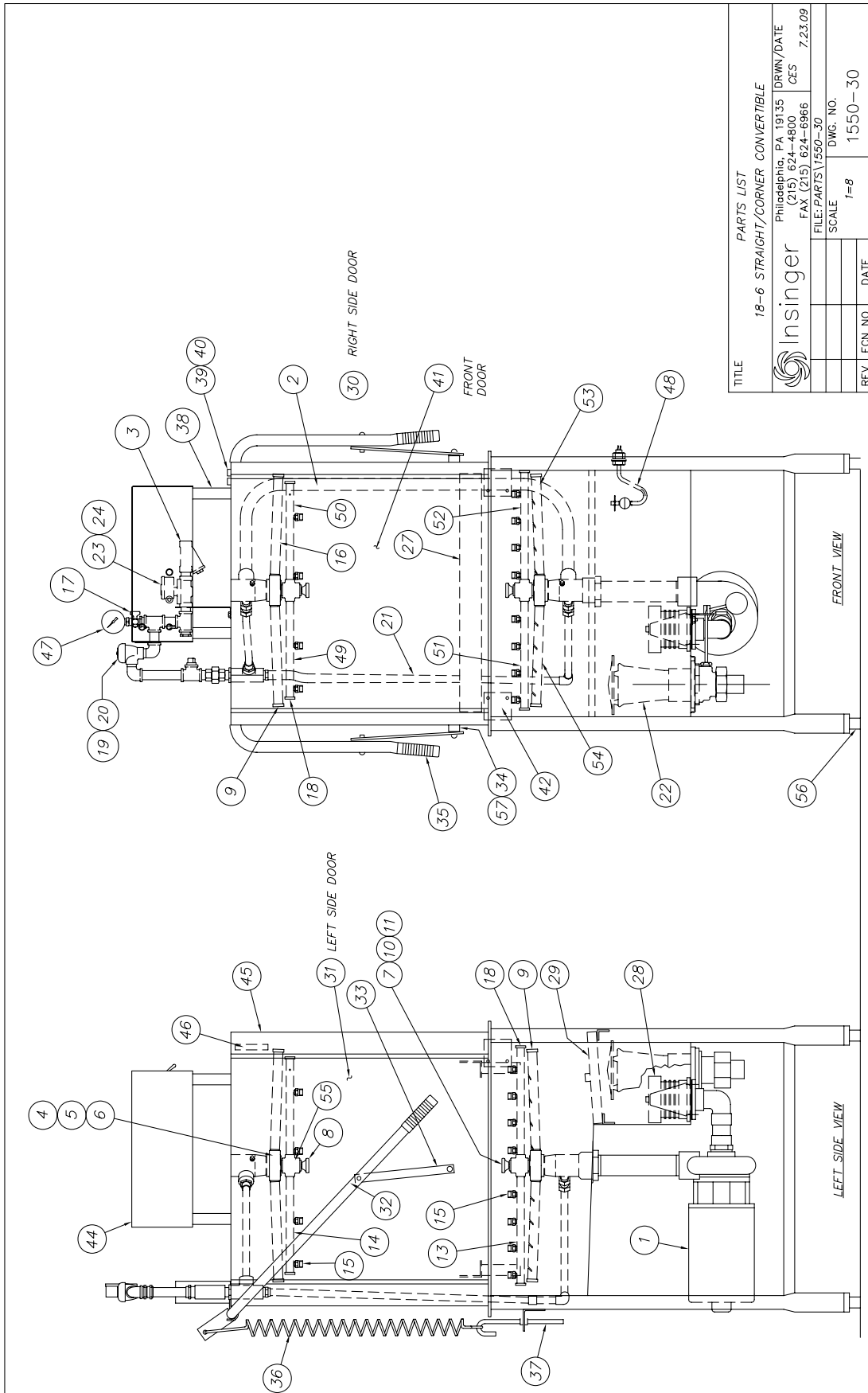

ITEM	MACHINE	PART No.	DESCRIPTION	REQ.
1	18-6, CS-6	1089-19	PUMP & MOTOR ASS'Y (1 H.P. - SPECIFY VOLTAGE)	1
2		1551-23	DOOR WEAR STRIPS	6
3		D2483A	"Y" STRAINER, 1/2 (OMIT W/BUILT-IN BOOSTER)	1
4		1084-76	SPRAY HUB - WASH	2
5		D2-563	O-RING	2
6		952-27	BUSHING, PLASTIC (WASH ARM HUB)	2
7		1089-178	BUSHING, PLASTIC (RINSE ARM HUB)	1
8		1463-29	SUPPORT ASS'Y UPPER HUB	1
9		D2-554-2A	PLUG, 3/4-10 UNC-2A (WASH ARM)	4
10		D2-584	LOCKING SCREW	1
11		1084-22	HUB-LOWER RINSE ARM	1
12				
13		1434-9	LOWER SPRAY PIPE ASS'Y. - RINSE	1
14		1434-8	UPPER SPRAY PIPE ASS'Y. - RINSE	1
15		D3035	SPRAY NOZZLE - UPPER & LOWER RINSE ARM	12
16		1434-5	UPPER WASH PIPE	2
17		D2497	PETCOCK	1
18		D2-554-1A	PLUG, 9/16-12 UNC-2A (RINSE ARM)	4
19		D2241A	VACUUM BREAKER, 1/2	1
20		D2914RK	VACUUM BREAKER REPAIR KIT	1
21		1551-31	FINAL RINSE ASSEMBLY (W/ PARTS LIST)	1
22		SK-3028	DRAIN ASSEMBLY (W/PARTS LIST)	1
23		D2606	SOLENOID VALVE, 1/2 (OMIT W/BUILT-IN BOOSTER)	1
24		D2641	SOLENOID VALVE REPAIR KIT	1
25				1
26				1
27		1550-28	TRACK ASS'Y	1
28		D2-541	SUCTION STRAINER	1
29		1550-22	SCRAP SCREEN	2
30		1550-15R	DOOR - RIGHT SIDE	1
31		1550-15L	DOOR - LEFT SIDE	1
32		1084-25	DOOR ARM	1
33		1084-38	LINK, ARM-DOOR	2
34		957-26	SPACER, DOOR LINK	2
35		D2245	GRIP - DOOR HANDLE	2
36		SK-2294A-001	SPRING	2
37		957-27	SPRING EXTENSION - LOWER	2
38		1440-7	POST - CONTROL BOX	4
39		DE5-37	SWITCH, MAGNETIC	1
40		DE5-37A	MAGNET	1
41		1550-17	DOOR - FRONT	1
42		1550-16	DOOR CONNECTOR	2
43				
44		SK-3490	CONTROL BOX ASS'Y	1
45		1550-6R or L	CORNER POST COVER (specify left or right)	2
46		1551-9	RETAINER BAR - CORNER POST COVER	2
47		SK-1433	PRESSURE GAUGE	1
48		DE5-60	LIQUID LEVEL FLOAT ASSEMBLY	1
49		1434-7A	UPPER RINSE PIPE	1
50		1434-7B	UPPER RINSE PIPE	1
51		1434-7C	LOWER RINSE PIPE	1
52		1434-7D	LOWER RINSE PIPE	1
53		1089-23A	LOWER WASH PIPE	1
54		1089-23B	LOWER WASH PIPE	1
55		1463-25	RINSE HUB UPPER	1 EA
56		D2874	BULLET FOOT	4
57		D3099	DOOR PIVOT NUT 3/8-16 THIN SEALNUT	2

REV. ECH. NO. DATE
FILE: PARTS\1350-30

TOLERANCES
FRACTIONS ±1/64
DECIMALS ±.005
ANGLES ±.01°
UNLESS OTHERWISE SPECIFIED

INSINGER
Philadelphia, PA 19135
(215) 624-4800
FAX (215) 624-6966

PARTS LIST
18-6 STRAIGHT/CORNER CONV.
SCALE 1=8
USED ON 18-6
DRAWN/DATE CES 7.23.09

NEXT ASSY DWG. NO. 1550-30

SHT 2 OF 2

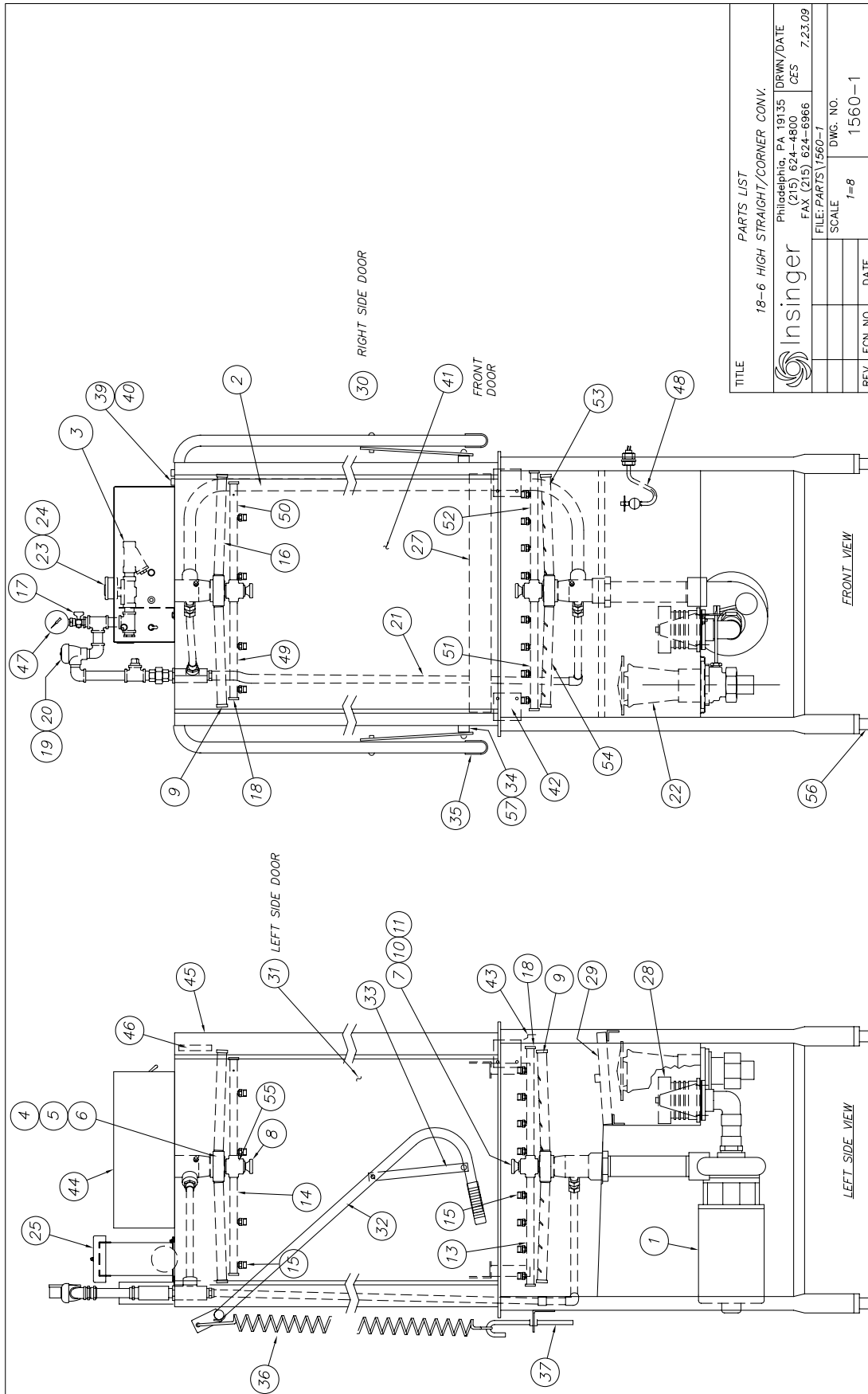

TITLE		PARTS LIST	
18-6 HIGH STRAIGHT/CORNER CONV.		18-6 HIGH STRAIGHT/CORNER CONV.	
Insinger		Philadelphia, PA 19135 DRWN/DATE	
		(215) 624-4800 CES	
		FAX (215) 624-6966	
		7.23.09	
		FILE:PARTS\1560-1	
		SCALE DWG. NO.	
		1=8 1560-1	
REV	ECN NO	DATE	

ITEM	MACHINE	PART No.	DESCRIPTION	REQ.
1	18-6H, 18-6HC	1089-19	PUMP & MOTOR ASS'Y (2 H.P. - SPECIFY VOLTAGE)	1
2		1172-97	DOOR WEAR STRIPS	6
3		D2483A	"Y" STRAINER, 1/2 (OMIT W/BUILT-IN BOOSTER)	1
4		1084-76	SPRAY HUB - WASH	2
5		D2-563	O-RING	2
6		952-27	BUSHING, PLASTIC (WASH ARM HUB)	2
7		1089-178	BUSHING, PLASTIC (RINSE ARM HUB)	1
8		1463-29	SUPPORT ASS'Y UPPER HUB	1
9		D2-554-2A	PLUG, 3/4-10 UNC-2A (WASH ARM)	4
10		D2-584	LOCKING SCREW	1
11		1084-22	HUB-LOWER RINSE ARM	1
12				
13		1434-9	LOWER SPRAY PIPE ASS'Y. - RINSE	1
14		1434-8	UPPER SPRAY PIPE ASS'Y. - RINSE	1
15		D3035	SPRAY NOZZLE - UPPER & LOWER RINSE ARM	12
16		1434-5	UPPER WASH PIPE	2
17		D2497	PETCOCK	1
18		D2-554-1A	PLUG, 9/16-12 UNC-2A (RINSE ARM)	4
19		D2241A	VACUUM BREAKER, 1/2	1
20		D2914RK	VACUUM BREAKER REPAIR KIT	1
21		1551-31	FINAL RINSE ASSEMBLY (W/ PARTS LIST)	1
22		SK-3028	DRAIN ASSEMBLY (W/PARTS LIST)	1
23		D2606	SOLENOID VALVE, 1/2 (OMIT W/BUILT-IN BOOSTER)	1
24		D2641	SOLENOID VALVE REPAIR KIT	1
25		1560-25	HOOD TOP VENT ASSEMBLY	1
26				1
27		1550-28	TRACK ASS'Y	1
28		D2-541	SUCTION STRAINER	1
29		1550-22	SCRAP SCREEN	2
30		1560-15R	DOOR - RIGHT SIDE	1
31		1560-15L	DOOR - LEFT SIDE	1
32		1560-24	DOOR ARM	1
33		1463-8	LINK, ARM-DOOR	2
34		1463-7	SPACER, DOOR LINK	2
35		D2245	GRIP - DOOR HANDLE	2
36		SK-2294A-001	SPRING (3 DOOR - STRAIGHT)	3
			SPRING (2 DOOR - CORNER)	2
37		957-27	SPRING EXTENSION - LOWER (3 DOOR - STRAIGHT)	3
			SPRING EXTENSION - LOWER (2 DOOR - CORNER)	2
38				
39		DE5-37	SWITCH, MAGNETIC	1
40		DE5-37A	MAGNET	1
41		1560-17	DOOR - FRONT	1
42		1550-16	DOOR CONNECTOR	2
43		1560-18	DOOR GUTTER	2
44		SK-3490	CONTROL BOX ASS'Y	1
45		1560-6R or L	CORNER POST COVER (specify left or right)	2
46		1551-9	RETAINER BAR - CORNER POST COVER	2
47		SK-1433	PRESSURE GAUGE	1
48		DE5-60	LIQUID LEVEL FLOAT ASSEMBLY	1
49		1434-7A	UPPER RINSE PIPE	1
50		1434-7B	UPPER RINSE PIPE	1
51		1434-7C	LOWER RINSE PIPE	1
52		1434-7D	LOWER RINSE PIPE	1
53		1089-23A	LOWER WASH PIPE	1
54		1089-23B	LOWER WASH PIPE	1
55		1463-25	RINSE HUB UPPER	1 EA
56		D2874	BULLET FOOT	4
57		D3099	DOOR PIVOT NUT 3/8-16 THIN SEALNUT	2

TOLERANCES
 FRACTIONS ±1/64
 DECIMALS .XXX ±.005
 ANGLES ±1/2°
 OTHERS AS SPECIFIED

TITLE
 18-6 HIGH STRAIGHT/CORNER

PARTS LIST
 REGD. -
 SCALE 1-8
 USED ON 18-6H
 DRWN/DATE
 CCS. 7.23.09

Insinger
 Philadelphia, PA 19135
 (215) 624-4800
 FAX (215) 624-8966

REV. ECN NO. DATE
 FILE:PARTS\1560-1

SHT 2
OF 2

ITEM	PART NO.	DESCRIPTION	QTY.
1	D3110	HATCO SCB 208/240 3PH	1
	D3111	HATCO SCB 380 - 3PH	
	D3112	HATCO SCB 480 - 3PH	
	D3113	HATCO SCB 208/240 1PH	
7	D2508A	PRESS. REG. & STRAINER 1/2 IPS	1
10	D2930	SOLENOID VALVE 1/2 IPS	1
11	D318A-D3-D2	ST. UNION 1/2 MIPS x 1/2 C	1
12	D316A-D3-D3	90° ELL. 1/2 C	3
13	D316A-D3-E1	90° ST. ELL. 3/4 FIPS x 1/2 C	2
14	D319A-D3-D3	90° UNION ELL. 1/2 C	1
15	D319A-D3-D2	90° UNION ELL. 1/2 MIPS x 1/2 C	1
16	D329F-E2-B1	HEX RED. 3/4 MIPS x 1/4 FIPS	1
17	D329-5	DRAIN VALVE 1/4 IPS	1
18	D207A-B4-19	COPPER TUBING 1/2 CTS X 4 3/4" LG	1
19	D207A-B4-23	COPPER TUBING 1/2 CTS X 5 3/4 LG	1
20	D207A-B4-27	COPPER TUBING 1/2 CTS X 6 3/4 LG	1
	D207A-B4-188	COPPER TUBING 1/2 CTS X 47 LG	1
21	D207A-B4-244	COPPER TUBING 1/2 CTS X 61 LG (X-H)	1
22	D207A-B4-8	COPPER TUBING 1/2 CTS X 2 LG	1
23	925-49	FINAL RINSE PIPING BRACKET	1
24	D314F-D5-16	1/2 IPS NIPPLE x 2" LG.	1

REF. #1463-18
OMIT SOLENOID

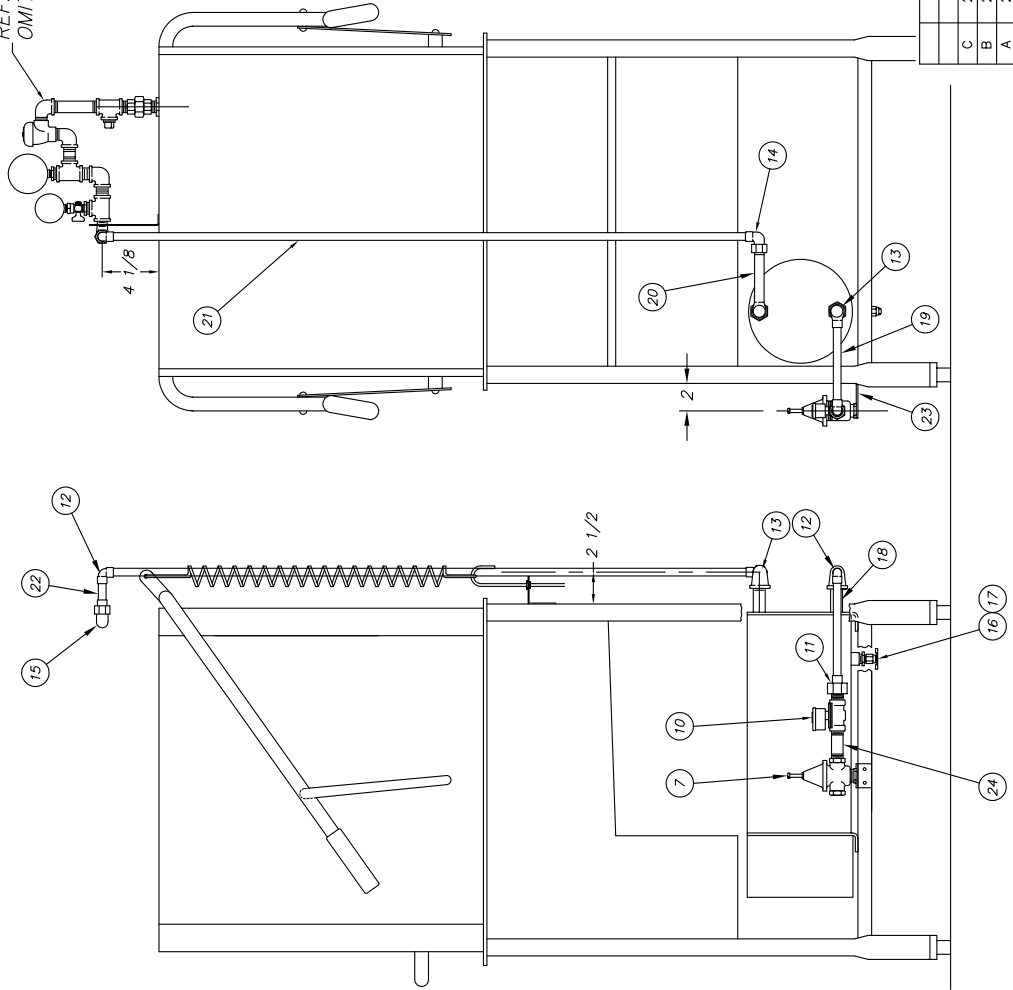

SERVICE NOTE

IF A HATCO LOW PRESSURE BOOSTER IS REPLACING A HUBBELL OR INSINGER HIGH PRESSURE BOOSTER, THE 1/2 IPS SOLENOID VALVE MUST BE REMOVED FROM THE TOP OF THE MACHINE & INSTALLED ON THE INLET TO THE BOOSTER AS SHOWN ON DMG SK-4880.

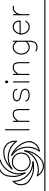
TOLERANCES	TITLE	LOW PRESSURE HATCO	NEXT ASSY/DWG. NO.
FRACTIONS ±1/64	70° RISE SCB	INSTALL	REQ'D 1551-20
DECIMALS ±.005	MAT'L		SCALE USED ON
XX ±.015			1-8
UNLESS ±1/2"			18-5
OTHERWISE SPECIFIED			DRWN/DATE
			CES
REV ECN NO DATE	 Philadelphia, PA 19135 (215) 624-4800 FAX (215) 624-6966		
FILE: PARTS\1551-20	1.9.08		

ITEM	PART NO.	SIZE	DESCRIPTION	QTY.
1	1394-1	B	BOOSTER ASSEMBLY	1
2	D319A-D3-D3	-	90° UNION ELBOW 1/2" C	1
3	D319A-D3-D2	-	90° UNION ELBOW 1/2" C X 1/2" MIPS	1
4	D316A-D3-D3	-	90° ELBOW 1/2" C	3
5	D317A-D3-D2	-	ADAPTER 1/2" C X 1/2" MIPS	1
6	D207A-K4-12	-	COPPER TUBING 1/2" CTS X 3" LONG	1
7	D207A-K4-172	-	COPPER TUBING 1/2" CTS X 43" LONG	1
8	D207A-K4-86	-	COPPER TUBING 1/2" CTS X 21 1/2" LG	1
9	D207A-K4-72	-	COPPER TUBING 1/2" CTS X 18" LONG	1
10	D320FE1D1E1	-	TEE 3/4 FIPS X 1/2 FIPS X 3/4 FIPS	1
11	D2507	-	PRESSURE RELIEF VALVE 3/4 MIPS	1
12	D314F-DS-32	-	NIPPLE 1/2" IPS X 4" LONG	1

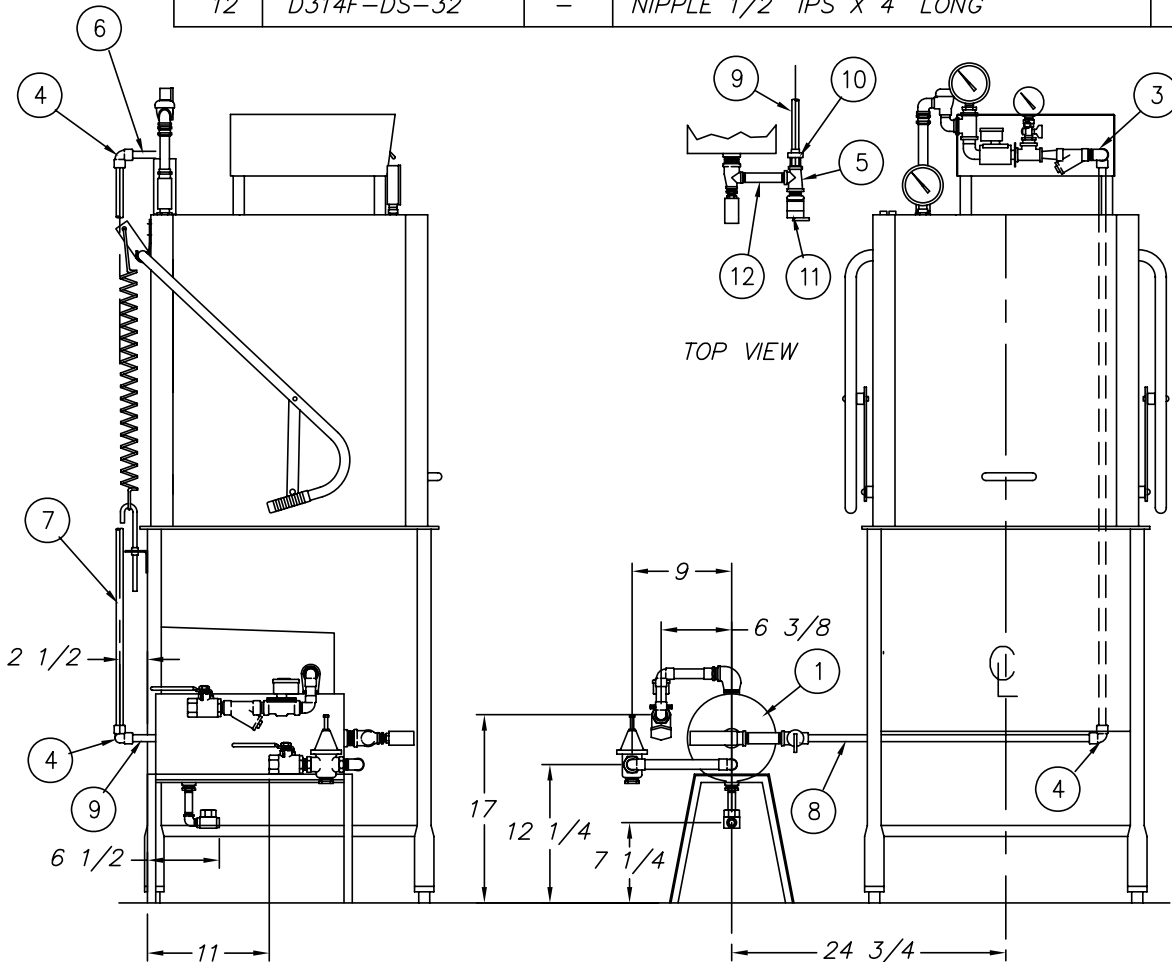

			TOLERANCES	TITLE	NEXT ASSY	DWG. NO.
			FRACTIONS ±1/64	SIDE MOUNT STEAM BOOSTER	REQ'D 1	1089-179
			DECIMALS	TO FINAL RINSE PIPING ASS'Y		
B	1916	2.22.02	.XXX ± .005		SCALE	USED ON 18-5
A	1761	6.19.00	.XX ± .01		1/16	50-20N2-NSU
REV	ECN NO	DATE	ANGLES ±1/2°	MAT'L		DRWN/DATE
			UNLESS	NOTED		RFN
			OTHERWISE			6-5-90
			SPECIFIED			
					Philadelphia, PA 19135	
					(215) 624-4800	
					FAX (215) 624-6966	

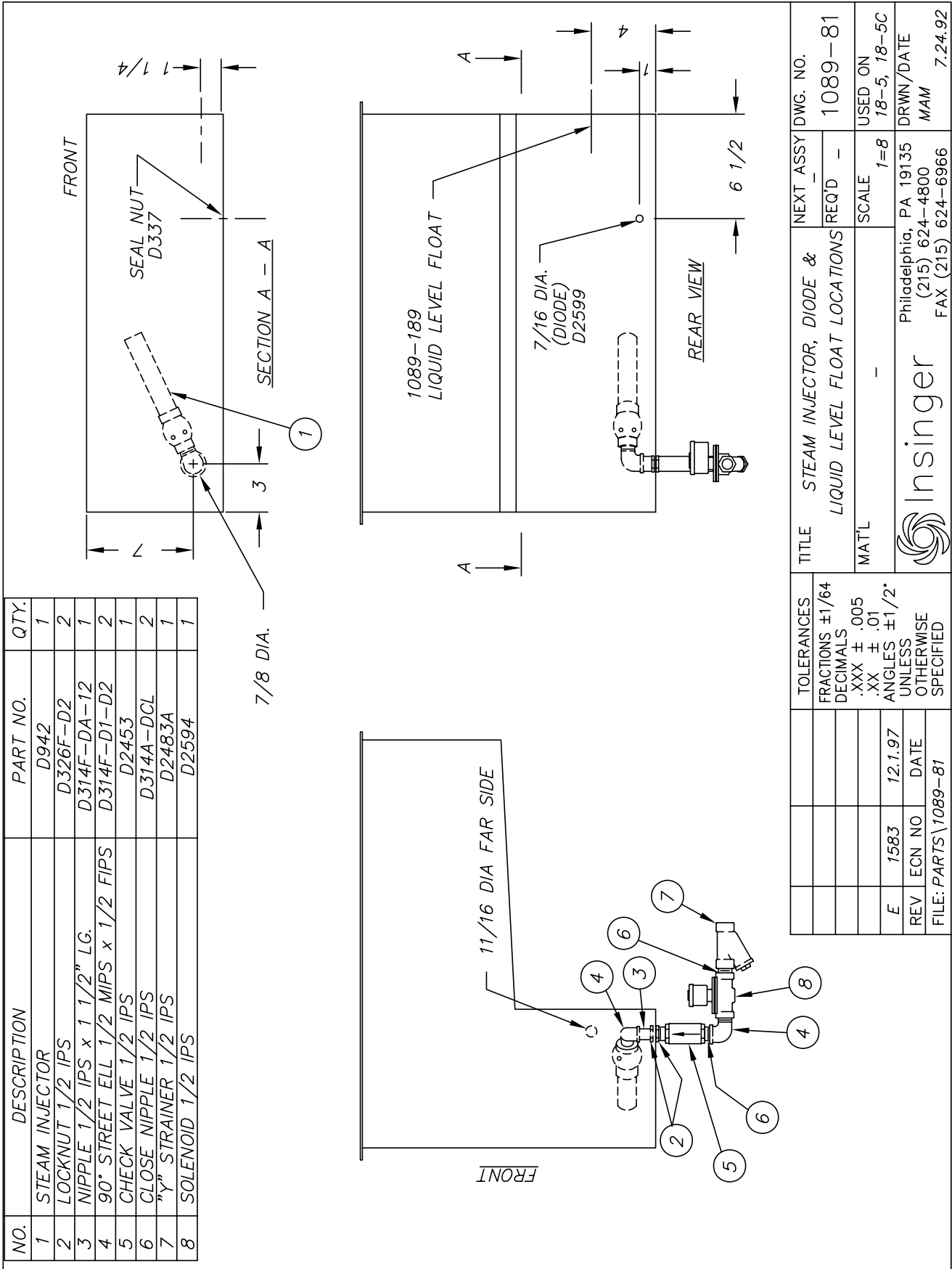

NO.	PART NO.	DESCRIPTION	QTY.
1	DE5-61	HI-TEMP. CUT-OFF SWITCH 3/8 NPT	1
2	1192-11	BRACKET, CUT-OFF SWITCH	1
3	D312C-DC-2	NUT, HEX #8-32	3
4	D2839	HOSE CLAMP, S/S	2
5	D318F-B5-B5	BULKHEAD FITTING	1
6	D3-545	"O" RING	1

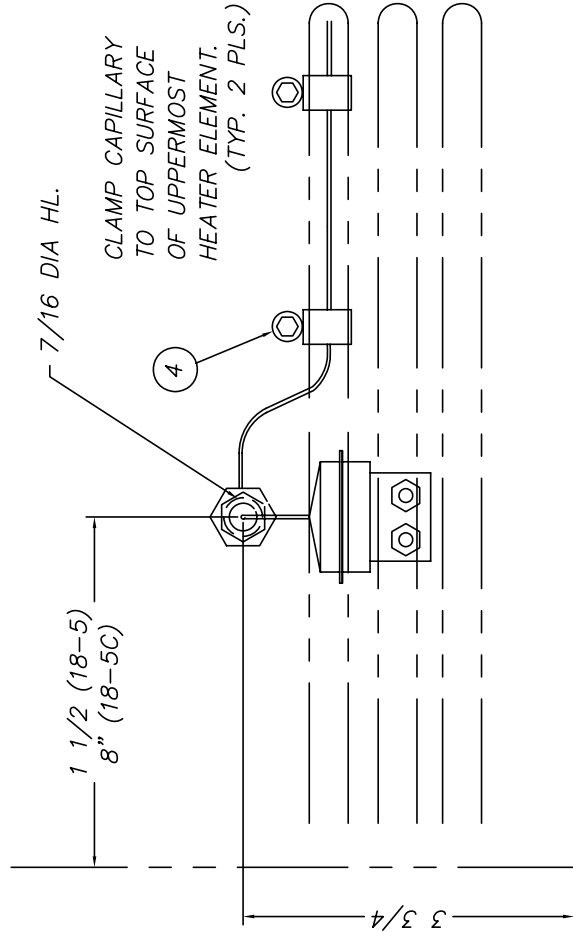

TOLERANCES		TITLE		NEXT ASSY DWG. NO.	
FRACTIONS ±1/64		HI-TEMP CUTOFF		REQ'D 1	1433-3
DECIMALS		SWITCH INSTALLATION		SCALE	USED ON
.XXX ± .005				1:2	18-5/18-5C
.XX ± .01					DRWN/DATE
ANGLES ±1/2°					CES
UNLESS OTHERWISE SPECIFIED					11.14.03
REV	ECN NO	DATE	 Philadelphia, PA 19135 (215) 624-4800 FAX (215) 624-6966		
FILE: PARTS\1433-3					

ITEM	PART NO.	DESCRIPTION	QTY.
1	D2-541	SUCTION STRAINER	1
2	D309C-JC-9A	HEX HD. S/S SCREW 3/8-16 x 1 1/8"	4
3	D313A-J1	COPPER WASHER 3/8	4
4	D312C-JC-5	LOCKNUT 3/8-16	4
5	D514	GASKET, PUMP FLANGE	1
6	D134	PUMP FLANGE	1
7	D316E-H3-H4	ELBOW 90° 1 1/2"C X 1 1/2 C FTG	1
8	D207E-K12-13	1 1/2 CU TUBE X 3 1/4 LG	1
9	D317E-H3-H2	ADAPTER 1 1/2"C X 1 1/2"M	1
10	D314F-HT-72	NIPPLE 1 1/2 IPS x 9" LG. LOE	1
11	D326F-H1	LOCKNUT 1 1/2 IPS	1

* ELECTROLESS NICKEL PLATE REQUIRED

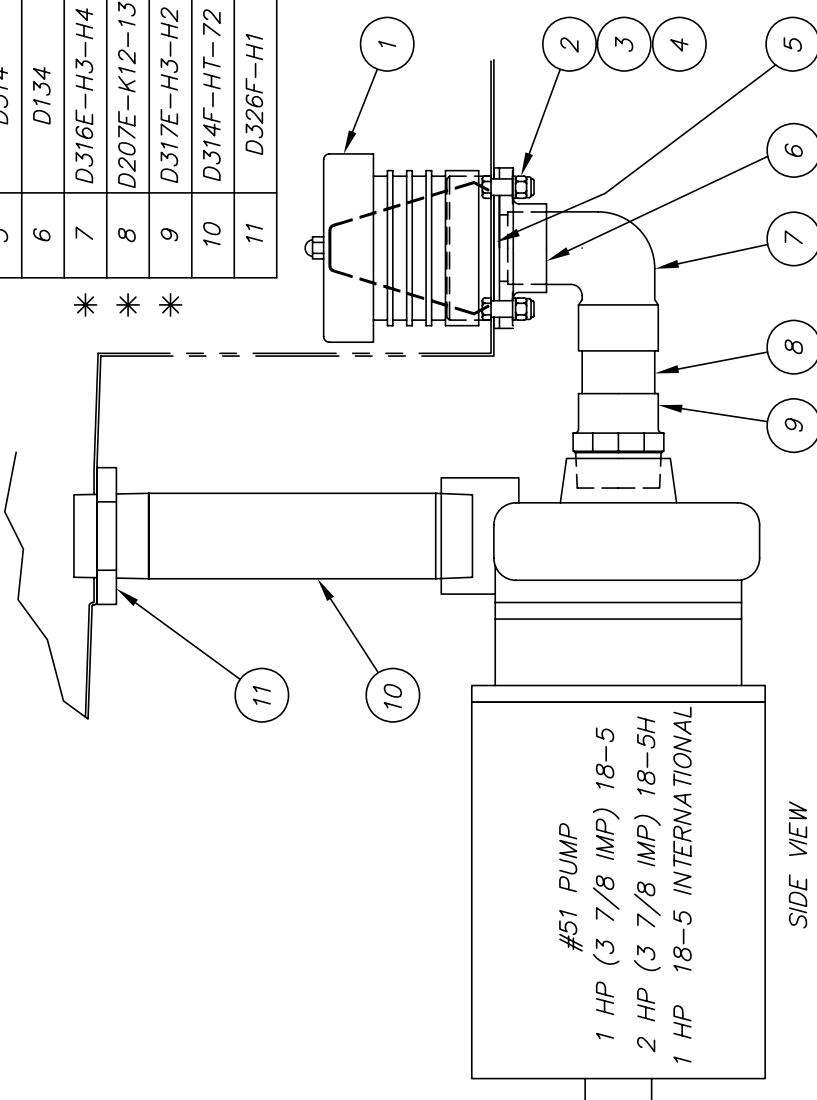

TOLERANCES	FRACTIONS ±1/64	TITLE	PUMP, MOTOR, & SUCTION ASSY
	DECIMALS .XXX ± .005	NEXT ASSY DWG. NO.	1089-19
	.XX ± .01	REQ'D	1
	ANGLES ±1/2°	SCALE	1=4
	UNLESS OTHERWISE SPECIFIED	MAT'L	USED ON 185, CS-5
REV	ECN NO	DATE	DRWN/DATE
F	1972	3.12.03	19135
E	1634	10.9.98	(215) 624-4800
D	1458	8.30.96	RFX
FILE: PARTS\1089-19			
		Philadelphia, PA 19135 (215) 624-4800 FAX (215) 624-6966	
		9.3.91	

NO.	DESCRIPTION	PART NO.	QTY.
1	LOCKNUT, HEX	D326F-D1	1
2	NIPPLE, CLOSE	D314F-DC-00	4
3	TEE	D320F-D1D1D1	3
4	PLUG, PIPE	D326F-D2A	1
5	UNION, STRAIGHT	D316F-D1-D1	1
6	NIPPLE, PIPE	D314F-DS-36	1
7	ELBOW, 90° STREET	D316F-D1-D2	2
8	BREAKER, VACUUM	D2914	1
9	NIPPLE, PIPE	D314F-DS-16	1
10	REDUCER, HEX	D322F-D2-B1	2
11	NIPPLE, PIPE	D314F-DS-14	1
12	NOT USED	---	---
13	VALVE, SOLENOID (WATER)	D2606	1
14	BRACKET, PIPING SUPPORT	951-79	1
15	PETCOCK	D2497	1
16	GAUGE, PRESSURE	SK-1433	1
17	TEE	D320F-D1D1D1	1
18	ADAPTER	D317C-D3-D2	2
19	TUBING, S/S	D207C-L5-36	2
20	UNION	D316C-D3-D1	2
21	REDUCER, FLUSH	D323A-D2-C1	2
22	FOR 18-5: TUBING, S/S	D207C-L5-112	1
23	FOR 18-5: TUBING, S/S	D207C-L5-153	1
24	FOR 18-5H: TUBING, S/S	D316C-D3-D3	1
25	ELBOW, 90°	D207C-L5-43	1
26	TUBING, S/S	1089-25	1
27	LOWER WASH PIPE ASSY	D2-563	2
28	O-RING	D2-584	1
29	SCREW, LOCKING	D2483A	1
30	STRAINER, "M"	1434-8	1
31	UPPER RINSE SPRAY PIPE ASSY	1434-8	1
32	LOWER RINSE SPRAY PIPE ASSY	D322F-D2-A1	1
33	REDUCER, HEX	D314F-DA-12	1
34	NIPPLE, PIPE	1463-29	1
35	SUPPORT ASSY, UPPER HUB	1434-6	1
36	UPPER WASH PIPE ASSY	D314C-DS-32	1
37	PIPE NIPPLE, S/S	D320C-D1D1D1	1
38	TEE, S/S	D314C-DA-12	1
39	PIPE NIPPLE, S/S	---	---
40	---	---	---
41	TEE, CPVC	D320C-D1D1D1	1
42	ADAPTER, CPVC	D317C-D3-D2	2
43	TUBING, CPVC	D207C-B4-33	1
44	ADAPTER	D329-1	2
45	TUBING, CPVC	D207C-B4-90	1
46	CLAMP, CPVC	D2-577-1	1
47	90° ELBOW, CPVC	D316C-D3-D3	1
48	TUBING, CPVC	D207C-B4-42	1
49	WELD STUD	D309C-EC-36	2
50	NIPPLE, CLOSE, S/S	D314C-DC-00	1
51	UNION, STRAIGHT, S/S	D316C-D1-D1	1
52	5/8" ID HOSE, X 3" LG	D3219	1
53	HOSE CLAMP, ALL S/S, SIZE #10	D2876	2

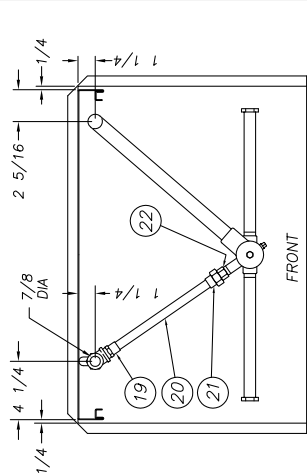
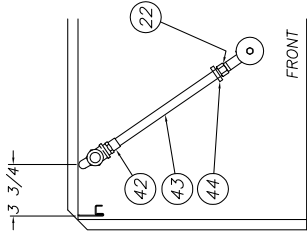

CS-6

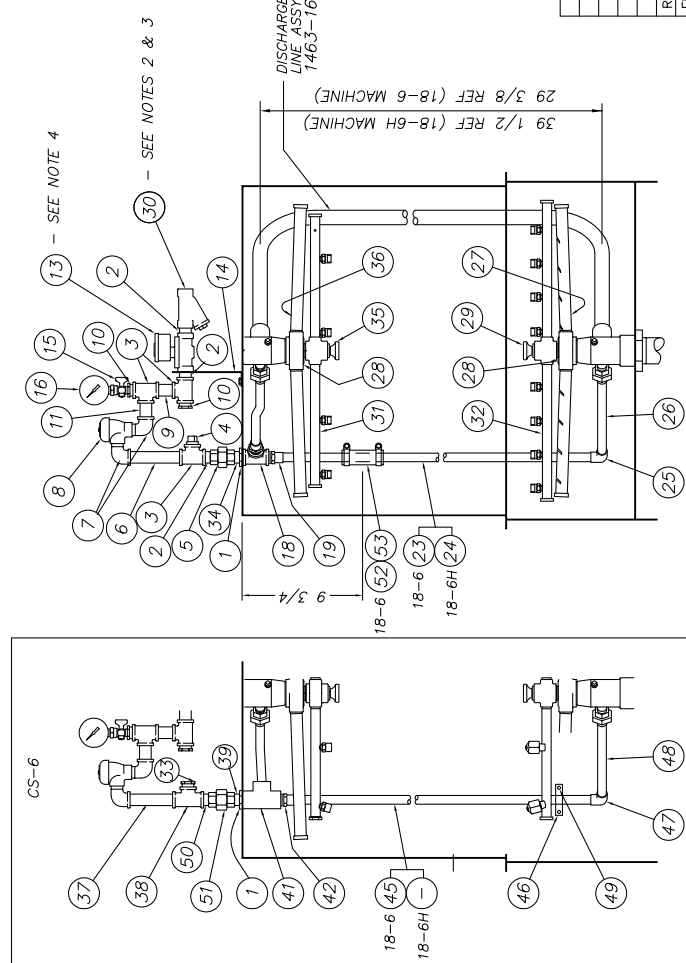

NOTES:
 1. * * * INDICATES ELECTROLESS NICKEL PLATED.
 2. ITEM #30 IS NOT REQUIRED WHEN A BOOSTER IS SPECIFIED, REPLACE WITH 90° UNION ELBOW 1/2 MIP S. X 1/2 COPPER.
 3. ITEM #30 IS NOT REQUIRED WHEN USING A SELF-CONTAINED BOOSTER.
 4. ITEM #13 NOT LOCATED WHERE SHOWN WHEN USING HATCO SELF-CONTAINED BOOSTER. SEE DWG #1551-32

TOLERANCES	TITLE	NEXT ASSY DWG. NO.
FRACTIONS ±1/64	FINAL RINSE ASS'Y 18-6	1551-31
DECIMALS	ALL EXCEPT S.C.B. (BOOSTER)	USED ON
.XXX ± .005	MATL	SCALE 1=8
.XX ± .01		18-6
.X ± .01		18-6
ANGLES ±1/2°		
OTHERWISE SPECIFIED		

Philadelphia, PA 19135
 (215) 624-4800
 (215) 624-4800
 FAX (215) 624-6866

Insinger
 Philadelphia, PA 19135
 (215) 624-4800
 (215) 624-4800
 FAX (215) 624-6866

NO.	DESCRIPTION	PART NO.	QTY.
1	LOCKNUT, HEX	D326F-D1	1
2	NIPPLE, CLOSE	D314F-DC-00	2
3	TEE	D320F-D1D1D1	4
4	FLUG, PIPE	D326F-D2A	1
5	UNION, STRAIGHT	D316F-D1-D1	1
6	NIPPLE, PIPE	D314F-DS-36	1
7	ELBOW, 90° STREET	D316F-D1-D2	1
8	BREAKER, VACUUM	D320A	1
9	NIPPLE, PIPE	D314F-DS-16	1
10	REDUCER, HEX	D322F-D2-B1	3
11	GAUGE, TEMPERATURE	D2495	1
12	NOT USED		
13	NOT USED		
14	BRACKET, PIPING SUPPORT	951-79	1
15	PETCOCK	D2497	1
16	GAUGE, PRESSURE	SK-1433	1
17	ADAPTER	D320A-D1D1D1	1
18	TEE	D317E-03-02	2
19	TUBING, S/S	D207C-B4-36	1
20	REDUCER, FLUSH	D323A-D2-C1	2
21	UNION	D207C-B4-112	1
22	FOR 18-S, TUBING, S/S	D316E-03-D3	1
23	FOR 18-BH, TUBING, S/S	D207C-B4-153	1
24	FOR 18-S, TUBING, S/S	D316E-03-D3	1
25	ELBOW, 90°	D207C-B4-39	1
26	TUBING, S/S	1089-25	1
27	LOWER WASH PIPE ASSY	D2-563	2
28	O-RING	D2-564	1
29	SCREW, LOCKING	1434-8	1
30	NOT USED	1434-8	1
31	UPPER RINSE SPRAY PIPE ASSY	1434-9	1
32	LOWER RINSE SPRAY PIPE ASSY		
33	NOT USED		
34	NIPPLE, PIPE	D314F-DA-12	1
35	SUPPORT ASSY, UPPER HUB	1463-29	1
36	UPPER WASH PIPE ASSY	1434-6	1
37	5/8" ID HOSE, 3" LG	D3219	1
38	HOSE CLAMP, ALL S/S, SIZE #10	D2876	2
39	NOT USED		
40	NOT USED		
41	NOT USED		
42	NOT USED		
43	NOT USED		
44	NOT USED		
45	NOT USED		
46	NOT USED		
47	NOT USED		
48	NOT USED		
49	NOT USED		
50	NOT USED		
51	NOT USED		

TOLERANCES	FRACTIONS ±1/64	DECIMALS	ANGLES	OTHER
C	2537	6.29.17	.XXX ± .005	±1/2°
B	XXX	05.20.11	.XXX ± .01	OTHERWISE SPECIFIED
A	2386	08.19.09	±.01	
REV	ECN NO	DATE		
	1551-32	07.20.09		

TITLE	FINAL RINSE ASSY	NEXT ASSY DWG. NO.
18-6 (W/ SELF CONTAINED BOOSTER)	REQD	1551-32
MATL	SCALE	USED ON
	1=8	18-6

REV	ECN NO	DATE	OTHER
	1551-32	07.20.09	

FILE: PARTS\1551-32

Philadelphia, PA 19135
(215) 624-4800
FAX (215) 624-6966

Insinger

NOTES:
1. * * * INDICATES ELECTROLESS NICKEL PLATED.

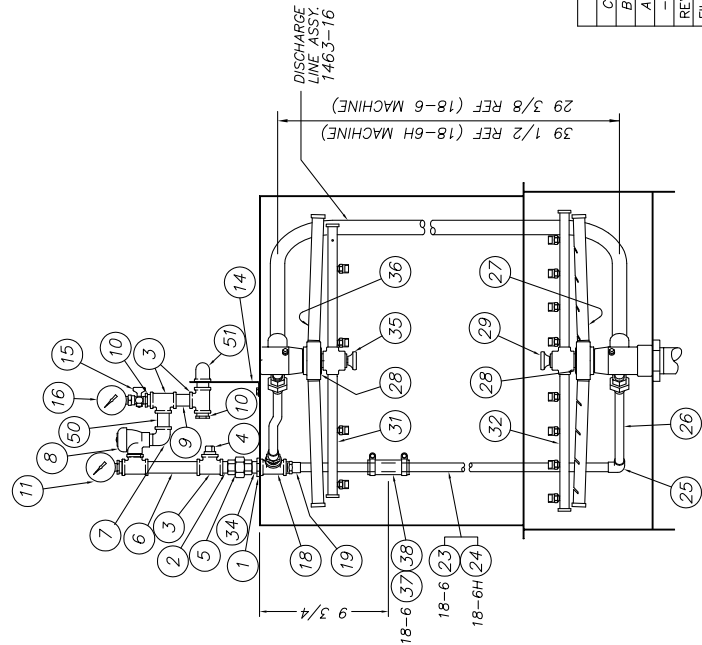
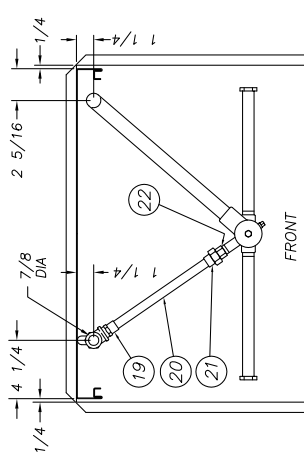

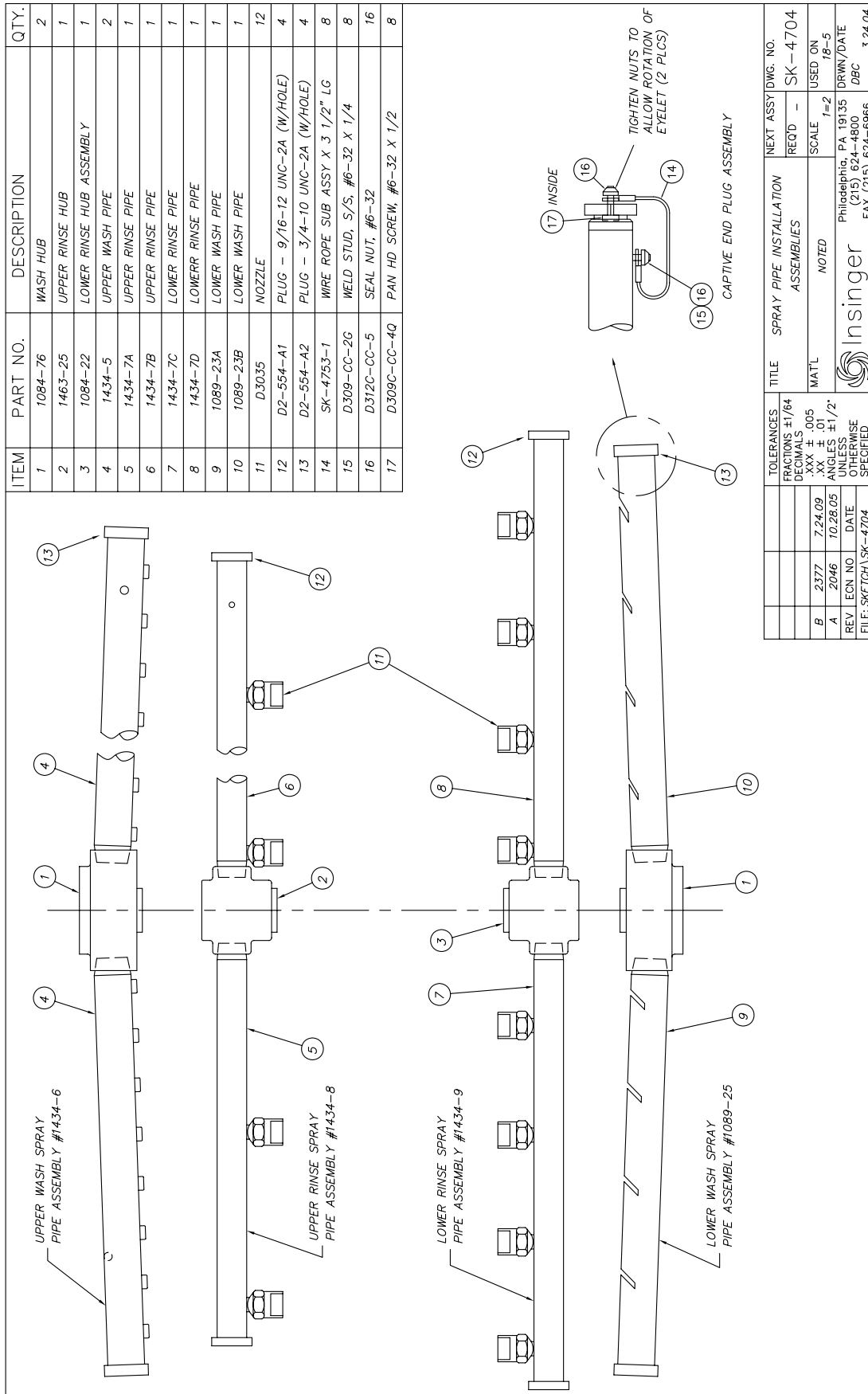

ITEM	PART NO.	DESCRIPTION	QTY.	ITEM	PART NO.	DESCRIPTION	QTY.
7	1084-76	WASH HUB	1	1	D2-584A	KNOB - LOWER	1
8	D2-563	"0" RING 1 3/4 OD X 3/32 W	1	2	1089-178	INSERT BUSHING - RINSE HUB	1
9	D309C-EF-2H	#10-32 X 1/4" SETSCREW	1	3	1089-177	BUSHING - RINSE HUB	1
10	D328A-A2	PIPE PLUG 1/8 IPS	1	4	372-52	HUB MACHINING	1
11	1084-34	SHAFT ASSEMBLY	1	5	1084-35	BUSHING - RINSE HUB	1
12	1089-16	DISCHARGE TEE - LOWER	1	6	952-27	BUSHING - WASH HUB	1
13	D314C-C-20	NIPPLE 3/8 IPS X 2 1/2 LG.	1				

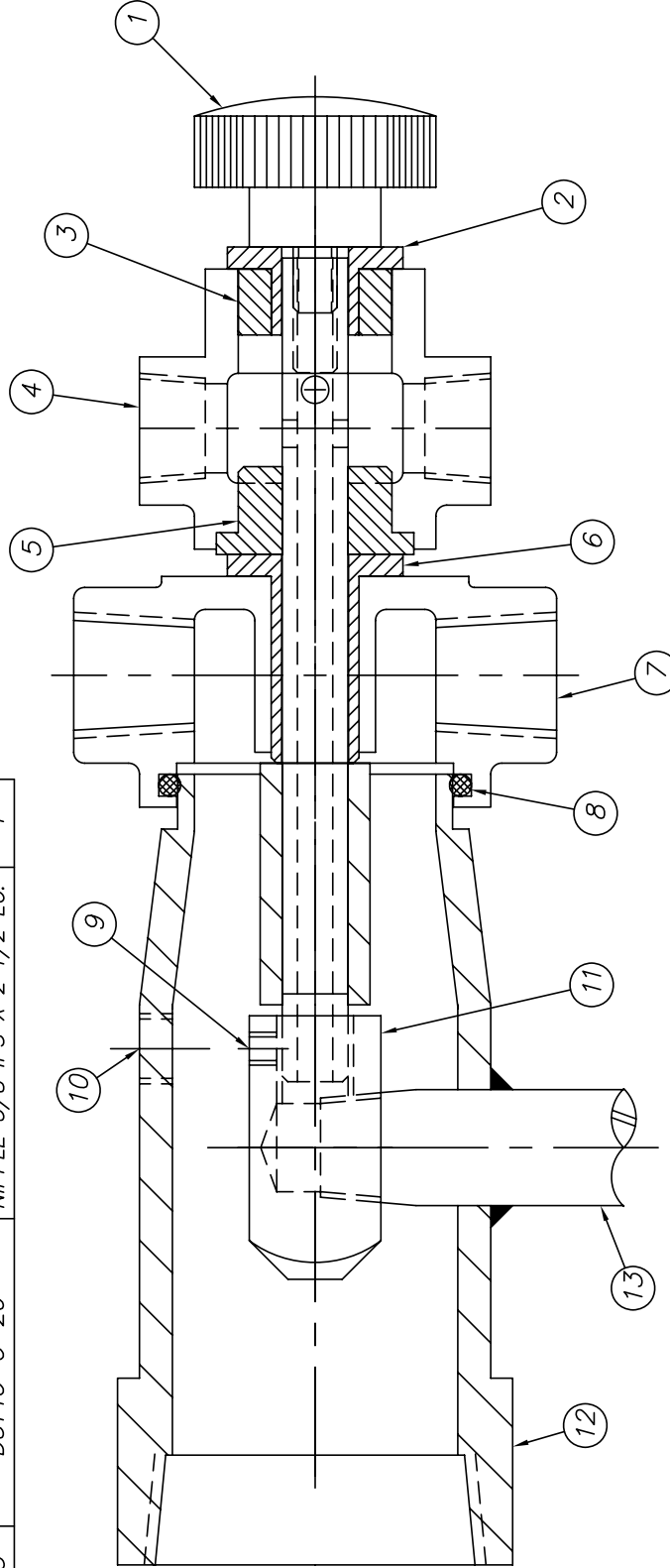

* LOWER RINSE HUB ASSEMBLY
#1084-22 CONSISTS OF:
(1) #372-52 HUB MACHINING
(1) #1084-35 BUSHING
(1) #1089-177 BUSHING
(1) #1089-178 BUSHING

TOLERANCES	TITLE	NEXT ASSY DWG. NO.
FRACTIONS ±1/64	18-4 & 18-5	SK-4705
DECIMALS	LOWER MANIFOLD ASSY	REQ'D -
.XXX ± .005	MAT'L	SCALE
.XX ± .01		1=1
ANGLES ±1/2°		USED ON
UNLESS OTHERWISE SPECIFIED		18-4 & 18-5
REV	ECN NO	DRWN/DATE
		DBC
FILE: SKETCHA \ SK-4703		

Insinger
Philadelphia, PA 19135
(215) 624-4800
FAX (215) 624-6966
DRWN/DATE
DBC
3.24.04

ITEM	PART NO.	DESCRIPTION	QTY.	ITEM	PART NO.	DESCRIPTION	QTY.
7	1084-34	SHAFT ASSEMBLY	1	1	1463-29	SUPPORT ASSY - UPPER HUB	1
8	D328A-A2	PIPE PLUG, 1/8 IPS	1	2	1463-25	RINSE HUB - UPPER	1
9	1089-15C	DISCHARGE TEE - UPPER	1	3	952-27	BUSHING - WASH HUB	1
10	1089-28	PLUG (PRESS FIT)	1	4	1084-76	WASH HUB	1
11	D314C-C-20	NIPPLE 3/8 IPS X 2 1/2 LG.	1	5	D2-563	"0" RING, 1 3/4 OD X 3/32 W	1
				6	D309C-EF-2H	#10-32 X 1/4" SETSCREW	1

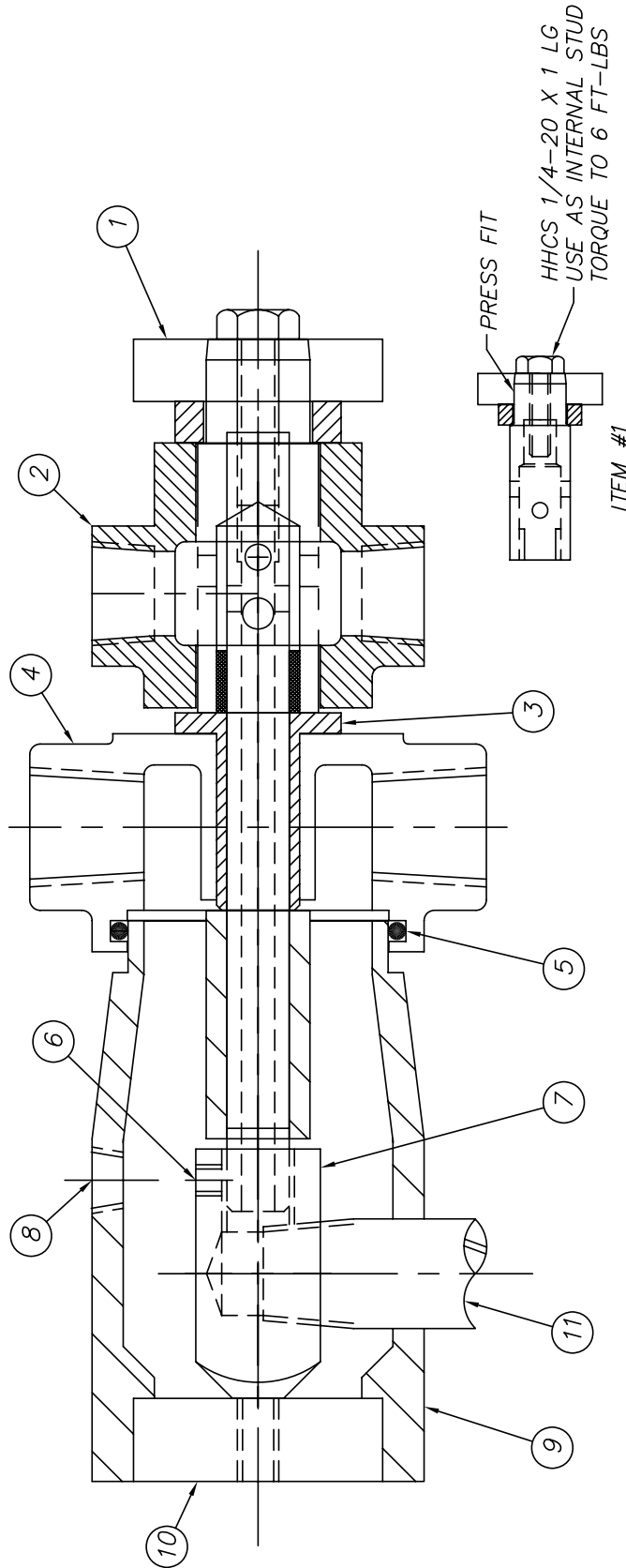

SCALE: 1/2

* ITEM #1 SUB-ASSEMBLY CONSISTS OF: #1463-26 BEARING BOSS #1463-27 THRUST COLLAR #1463-28 KNURLED KNOB D309C-GC-8A 1/4-20 X 1 LG HHCS	TOLERANCES	FRACTIONS ±1/64	DECIMALS	.XXX ± .005 .XX ± .01	ANGLES ±1/2°	UNLESS OTHERWISE SPECIFIED
	REV	ECN NO	DATE	FILE: SKETCHA \ SK-4073		
	A	2007	3.25.04			
TITLE		UPPER MANIFOLD ASSEMBLY		NEXT ASSY	DWG. NO.	
MATERIAL		NEW STYLE 18-5		REQ'D	1	SK-4073
SCALE		NOTED		SCALE	FULL	USED ON
PHILADELPHIA, PA 19135		FAX (215) 624-4800		TORQUE TO 6 FT-LBS		18-5
INSINGER Machine Company		DRWN/DATE		PRESS FIT		CES
INSINGER logo		11.18.98		ITEM #1		

<u>ITEM</u>	<u>PART NO.</u>	<u>PART NAME</u>	<u>QTY.</u>
	954-50	DRAIN ASS'Y (COMPLETE)	-
1	954-50A	UPPER VALVE BODY	1
2	954-50B	LOWER VALVE BODY	1
3	954-50C	O-RING NUT	1
4	1169-179D	OVERFLOW TUBE	1
5	D193	SKIMMER CAP	1
6	D2-557	CUP SEAL - DRAIN SEAT	1
7	954-9	SEALING WASHER	1
8	D2-549	"O" RING	1
9	D305A	DRAIN JAM NUT	1
10	D2-550	"O" RING	1
11	970-55	DRAIN HANDLE ASS'Y	1
12	954-8	BRACKET, DRAIN HANDLE	1
13	D2-507	BALL	1
14	954-7	SEALING WASHER	1
15	D3006	FLATWASHER, 5/8 OD	1

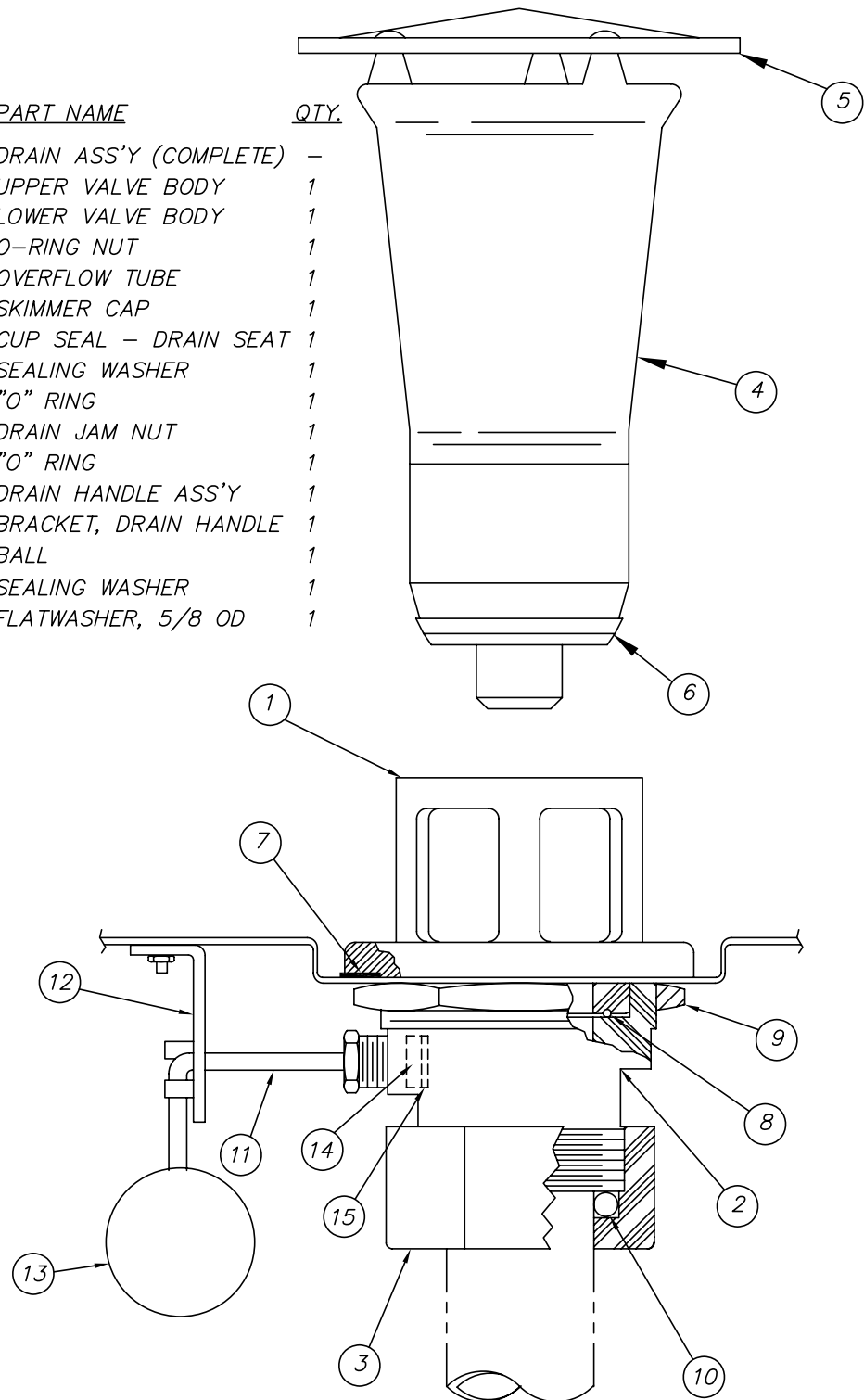

SK-3028

- △ ECN# 2377 7.24.09
- △ ECN# 1989 7.7.03
- △ ECN# 1761 5.5.00
- △ ECN# 1512 12.20.96

FILE: SKETCHA\SK-3028

MAM 2.11.93



Philadelphia, PA 19135
(215) 624-4800
FAX (215) 624-6966

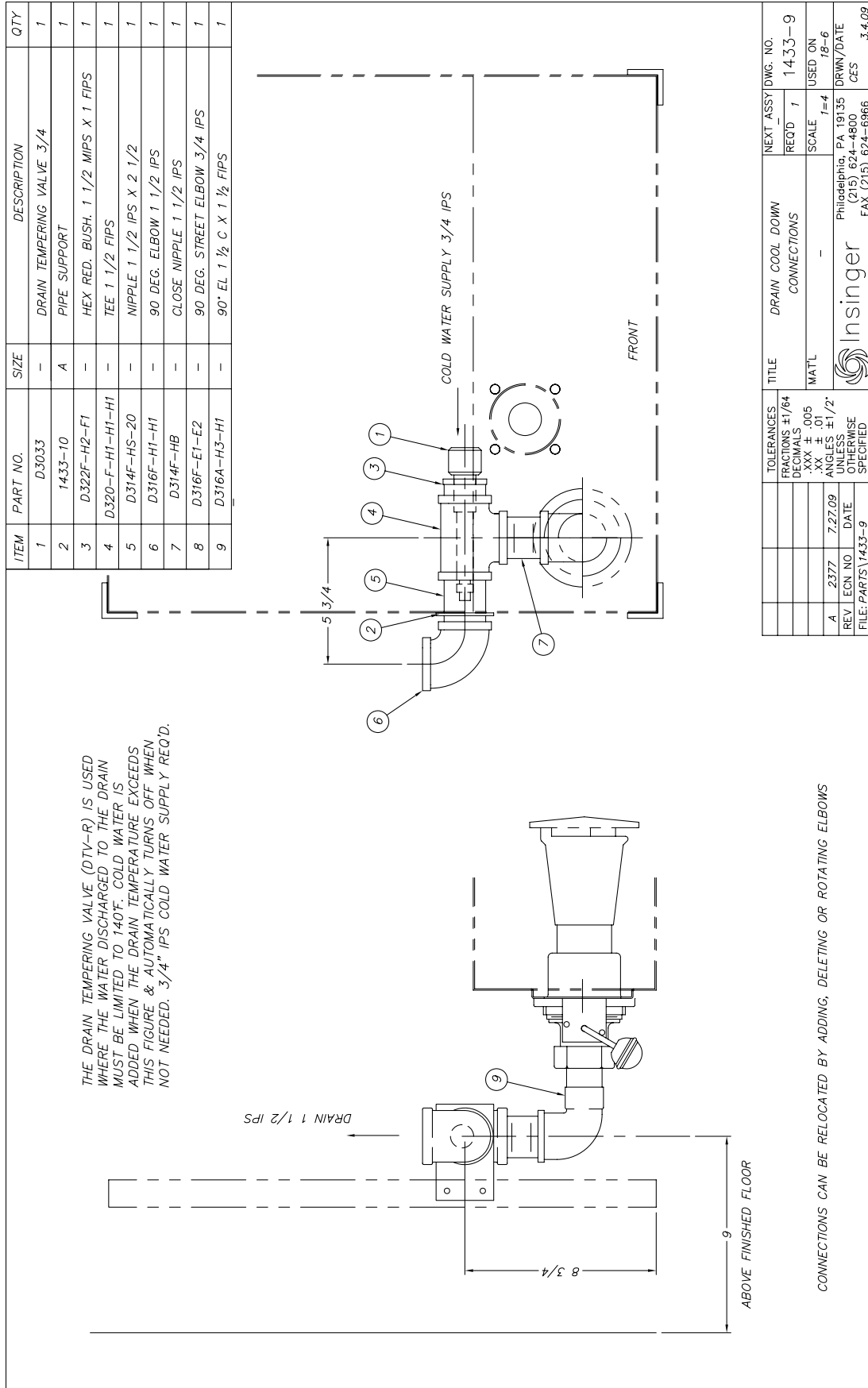

CONVERT 18-6 STRAIGHT TO CORNER

DOOR CONVERSION

All 3 doors open on a straight machine; only the front & right hand doors are used on a corner. The front is defined as facing the center door with the springs on the back. Remove the door connector bracket between the left & front doors. Fill the holes with the screws, flat washers & nuts. Disconnect the link between the left door stud and the handle and remove it. Back off the tension on the springs on the back of the machine. Test the operation of the doors. It may be necessary to remove the springs and turn the mounting angle upside down. Use 2 people, a 1/2 diameter rod and extreme care if disconnecting and reattaching springs. Be sure the door magnet is on an operating door.

TRACK CONVERSION

Current Track Assembly #1550-28 rev A: remove item #3 Track Fence from its position on the front track & insert the studs into the holes on the left hand cross track (at the non-opening door). The angle must face toward the inside of the machine. The rack will be sliding over the surface of this angle.

Early Track Assembly #1550-28 rev 0: remove #1550-14-2 vertical and discard. Install #1550-14-3 cross track - closed end on the left (at the non-opening door). Install #1550-14-5 cross track - open end on the right (at the opening door). Track arrangement should now match the view on the left of the drawing 'CORNER SET-UP'. If any parts are missing, contact parts@insingermachine.com or call 215-624-4800.

LEFT/RIGHT CONFIGURATION

See Installation Drawing 18-6C. Note how the machine is positioned in a left hand corner. It is rotated 90 degrees clockwise for installation into a right hand corner. This constitutes the conversion procedure.



Insinger Machine Company
6245 State Road
Philadelphia, PA 19135-2996

800-344-4802
Fax 215-624-6966
www.insingermachine.com