



Project \_\_\_\_\_  
 Item \_\_\_\_\_  
 Quantity \_\_\_\_\_  
 CSI - 11400 \_\_\_\_\_  
 Approval \_\_\_\_\_  
 Date \_\_\_\_\_

## SERIES G 15" ROTOR Commercial Food Waste Disposer

- Designed to handle huge quantities of the heaviest and toughest material encountered in central food waste areas
- Extra large 15" rotor with 10 HP motor generates maximum centrifugal force and impact disintegration speed.
- Rugged construction
- Ideal for the disposal of big steer ribs, leg or knuckle bones (even raw), lobster shells, poultry carcasses, fish heads, pineapples and regular or wax-coated paper waste

### STANDARD FEATURES

- 10 HP motor

### OPTIONS

- Stainless steel cone or sink attachment (includes vinyl silver trap ring, solenoid valve, flow control valve, vacuum breaker)
- Offset-body for maximum space utilization, also available for both cone & sink attachments
- Cones 12", 15", 18"

NOTE: Sink attachments and s/s cones need to be welded into the table.



#### O Style

Optional off-set body for use with bowl/cone trough





## SERIES G 15" ROTOR Commercial Food Waste Disposer

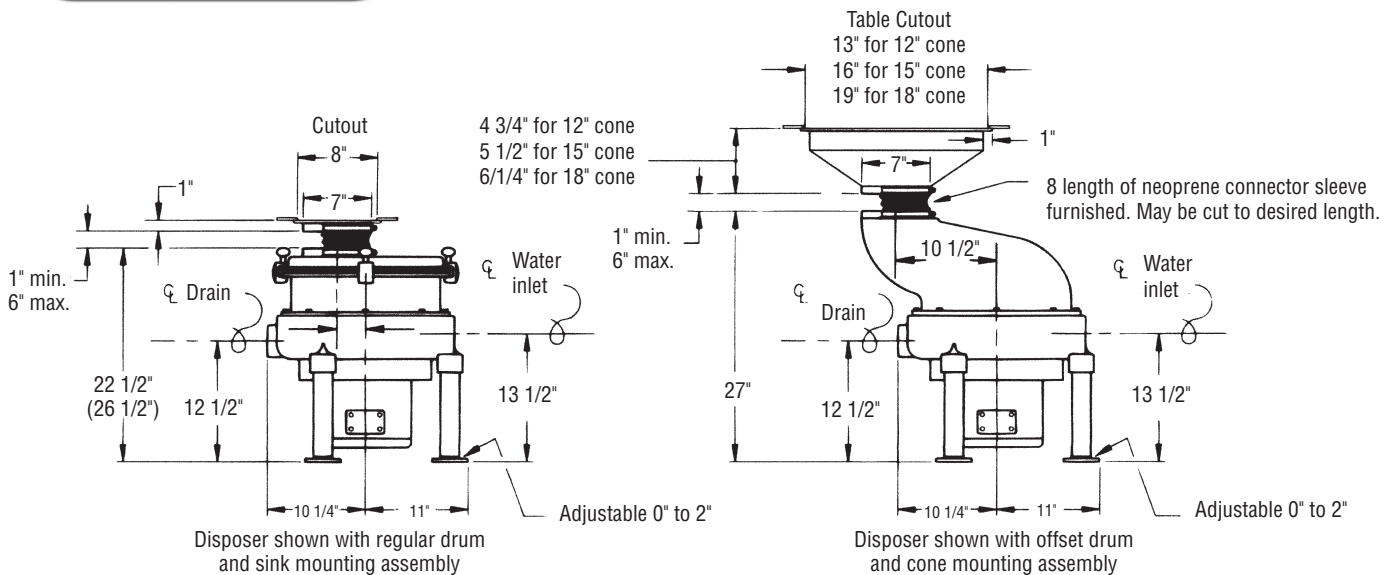

NOTE: All dimensions shown at 0" foot height adjustment.

### DESIGN AND CONSTRUCTION

- Waste chamber design permits dual directional operation when used with reversing control or switch, doubling the life cycle of the shattering mechanism.
- Basic body components are cast gray iron, machined, primed and painted. 15" diameter rotor with (2) bolt-on reversible impact bars and sizing ring are cast ductile iron, machined, balanced and heat treated
- Access to waste chamber by means of a cast aluminum lid having a 7" diameter throat opening, removable by means of quick-release head clamps
- Flexible drain connector. Fastens quickly to either metal or PVC drain line (3" pipe size)
- Stainless steel legs and feet, adjustable from 0" to 2"
- Disposer connects to cone or sink assembly by means of a neoprene isolation sleeve and (2) stainless steel clamps
- Offset design: for maximum space utilization, disposer also available with an 10 1/2" off-set waste chamber for both cone and sink attachments

### MOTOR

- Reversing, continuous duty, 1725 RPM (1425 RPM, 50 Hz), full rated horsepower, double sealed, permanently lubricated ball bearings
- Thermal overload protection (heaters) in control; must be sized as required
- Available for single phase or three phase installations
- Available in 10 HP, 3 phase
- Dual voltage windings: 208-230/460 Volts, 60 Hz  
190/380 Volts, 50 Hz

(See table for ampere draw per horsepower, volts & phase)

### CONTROLS

Electrical switches or control centers not included, must be selected as required.

**Note:** All plumbing and electrical connections should be made according to local codes.

Contact Insinger Sales at 800-344-4802 for an installation drawing specific to your application.  
This drawing is available on the Insinger website at [www.insingermachine.com](http://www.insingermachine.com)

Note: Due to product improvement we reserve the right to change information and specifications without notice.