



Project \_\_\_\_\_  
Item \_\_\_\_\_  
Quantity \_\_\_\_\_  
CSI - 11400 \_\_\_\_\_  
Approval \_\_\_\_\_  
Date \_\_\_\_\_

## SERIES N 8" ROTOR Commercial Food Waste Disposer

- Series "N" with 8" rotor has no floor support. Support leg is optional.
- It is designed primarily for the vegetable and salad preparation area of a medium to large kitchen.
- Ideal for the handling of general waste in a small restaurant.
- Recommended for the disposing of waste from a potato peeler.
- Equipped with a 2 HP motor, for heavier waste the 3 HP motor is recommended
- The 3 HP is also perfect for use in the pot and pan wash area where peak work loads are greater than anticipated
- Rugged construction
- Ideal for small church, snack bar, or elementary school where food waste volume is light.

### STANDARD FEATURES

- 2 HP motor

### OPTIONS

- Stainless steel cone or sink attachment (includes vinyl silver trap ring, solenoid valve, flow control valve, vacuum breaker)
- 1 1/2 HP motor- lighter duty
- 3 HP motor- heavier duty
- Offset-body for maximum space utilization, also available for both cone & sink attachments
- Cones 12", 15", 18"



#### O Style

Optional off-set body  
for use with bowl/cone  
trough





# SERIES N 8" ROTOR Commercial Food Waste Disposer

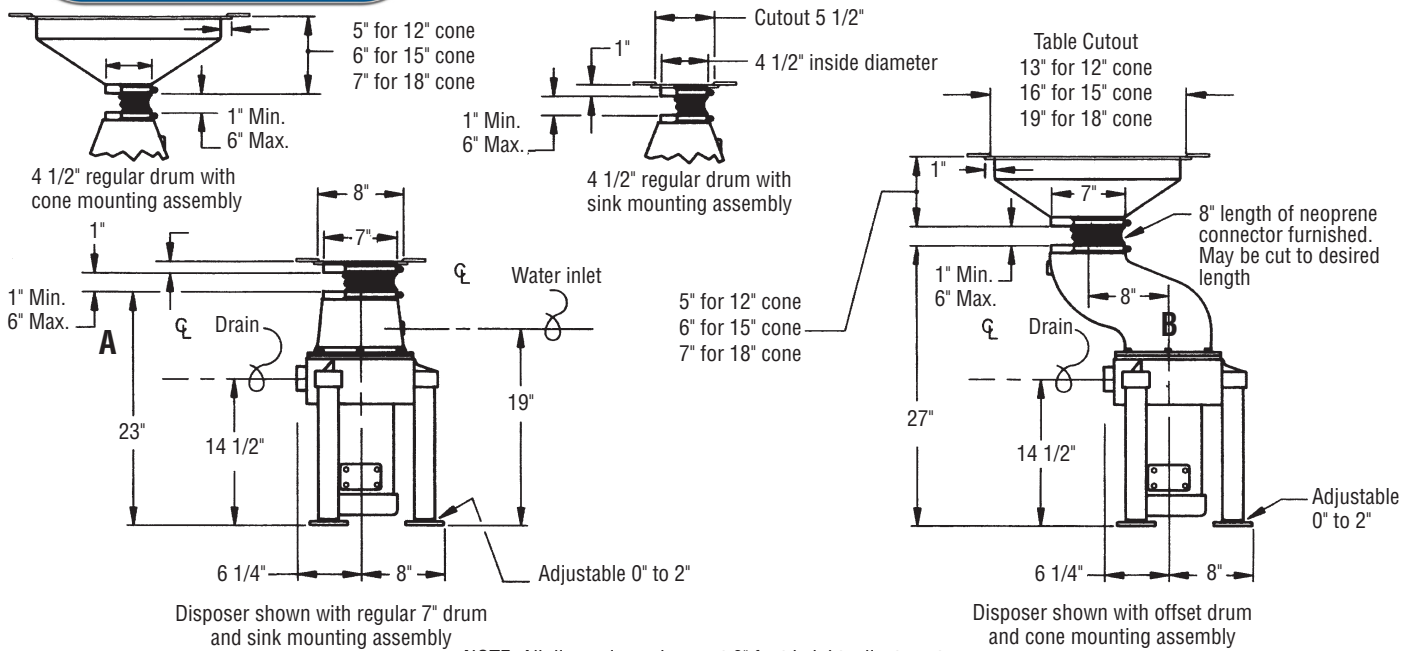

## DESIGN AND CONSTRUCTION

- Waste chamber design permits dual directional operation when used with reversing control or switch, doubling the life cycle of the shattering mechanism. Regular waste chamber available with either 4 1/2" or 7" throat size
- Basic body components are cast gray iron, machined, primed and painted. 8" diameter rotor with (2) bolt-on reversible impact bars and sizing ring are cast ductile iron, machined, balanced and heat treated
- Flexible drain connector. Fastens quickly to either metal or PVC drain line (2" pipe size)
- Stainless steel legs and feet, adjustable from 0" to 2"
- Disposer connects to cone or sink assembly by means of a neoprene isolation sleeve and (2) stainless steel clamps
- Offset Design: For maximum space utilization, disposer is also available with an 8" off-set waste chamber for both cone and sink attachments. (Available with 7" diameter throat size only)

## MOTOR

- Reversing, continuous duty, 1725 RPM (1425 RPM, 50 Hz), full rated horsepower, double sealed, permanently lubricated ball bearings
  - Thermal overload protection with manual reset button
  - Available for single phase or three phase installations
  - Available in 1 1/2 HP for light waste, 2 HP for standard use, 3 HP for heavy duty use
  - Dual voltage windings allow multi-voltage operation by motor lead connection. (See motor wiring diagram)
    - 115-230 Volts, 60 Hz; 110/220 Volts, 50 Hz, 1 Phase
    - 208-230/460 Volts, 60 Hz; 190/220/380-440 Volts, 50 Hz, 3 Phase
- (See table for ampere draw per horsepower, volts & phase)

## CONTROLS

Electrical switches or control centers not included, must be selected as required.

Note: All plumbing and electrical connections should be made according to local codes.

HP	SINGLE PHASE		THREE PHASE	
	Volts	Amps*	Volts	Amps*
1 1/2	115	17.2	208	4.9
	230	8.6	230	4.4
			460	2.2
2	115	18.4	208	6.9
	230	9.2	230	6.2
			460	3.1
3	N/A		208	9.7
			230	8.8
			460	4.4

\*Ratings are for 60 Hz operation.

Note: Due to product improvement we reserve the right to change information and specifications without notice.