



Project \_\_\_\_\_  
Item \_\_\_\_\_  
Quantity \_\_\_\_\_  
CSI - 11400 \_\_\_\_\_  
Approval \_\_\_\_\_  
Date \_\_\_\_\_

## SERIES S 10" ROTOR Commercial Food Waste Disposer

- Series "S" with 10" rotor and standard 5 HP motor
- Designed primarily for large commercial kitchens with heavy food waste
- Rugged construction
- Ideal for hospital, high school, medium to large restaurant, steak/rib/lobster house

### STANDARD FEATURES

- 3 HP motor
- 5 HP motor

### OPTIONS

- Stainless steel cone or sink attachment (includes vinyl silver trap ring, solenoid valve, flow control valve, vacuum breaker)
- Offset-body for maximum space utilization, available for both cone and sink attachments
- Cones 12", 15", 18"



**O Style**  
Optional off-set body  
for use with bowl/cone  
trough





# SERIES S 10" ROTOR Commercial Food Waste Disposer

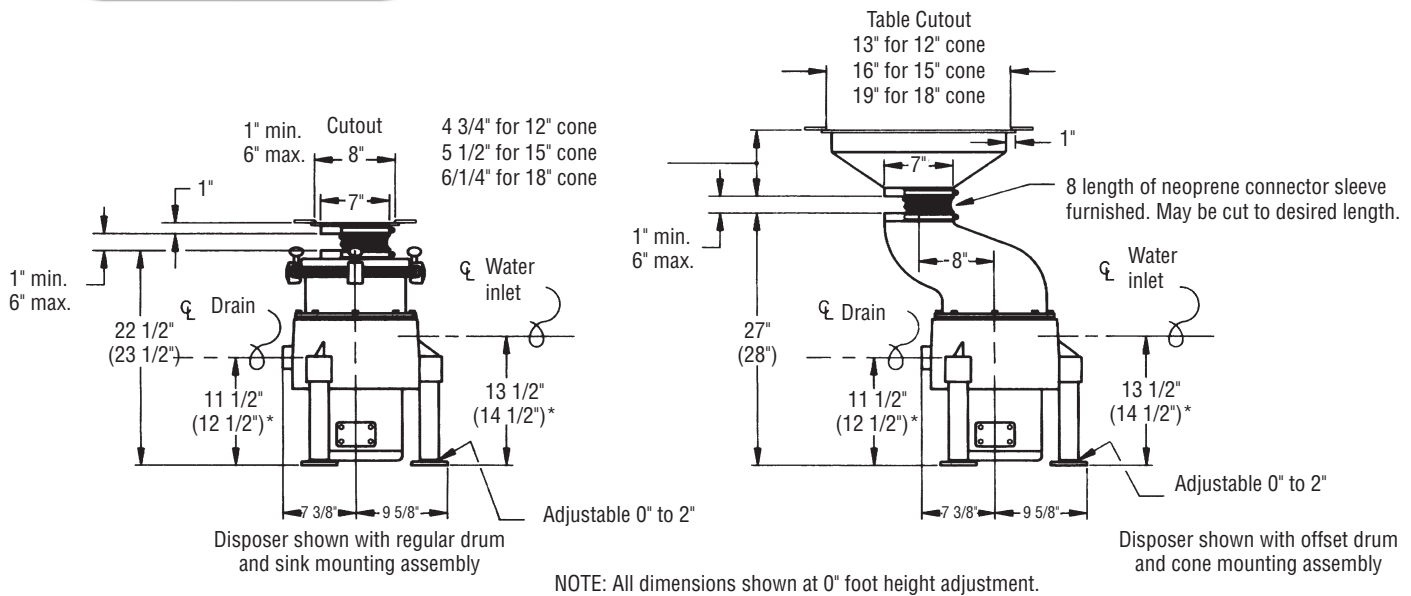

## DESIGN AND CONSTRUCTION

- Waste chamber design permits dual directional operation when used with reversing control or switch, doubling the life cycle of the shattering mechanism. Regular waste chamber available with 7" throat size
- Basic body components are cast gray iron, machined, primed and painted. 10" diameter rotor with (2) bolt-on reversible impact bars and sizing ring are cast ductile iron, machined, balanced and heat treated
- Access to waste chamber by means of a cast aluminum lid having a 7" diameter throat opening, removable by means of quick-release head clamps
- Flexible drain connector. Fastens quickly to either metal or PVC drain line (2" pipe size)
- Stainless steel legs and feet, adjustable from 0" to 2"
- Disposer connects to cone or sink assembly by means of a neoprene isolation sleeve and (2) stainless steel clamps
- Offset design: for maximum space utilization, disposer also available with an 8" off-set waste chamber for both cone and sink attachments

## MOTOR

- Reversing, continuous duty, 1725 RPM (1425 RPM, 50 Hz), full rated horsepower, double sealed, permanently lubricated ball bearings
- Thermal overload protection (heaters) in control; must be sized as required
- Available for single phase or three phase installations
- Available in 3 and 5 horsepower, three phase
- Dual voltage windings: 208-230/460 Volts, 60 Hz  
190/380 Volts, 50 Hz

(See table for ampere draw per horsepower, volts & phase)

## CONTROLS

Electrical switches or control centers not included, must be selected as required.

Note: All plumbing and electrical connections should be made according to local codes.

HP	THREE PHASE	
	Volts	Amps*
3	208	4.9
	230	4.4
	460	2.2
5	208	6.9
	230	6.2
	460	3.1

\*Ratings are for 60 Hz operation.

Note: Due to product improvement we reserve the right to change information and specifications without notice.