



Project _____
 Item _____
 Quantity _____
 CSI - 11400 _____
 Approval _____
 Date _____



CX20 VG

High Temp Door Type Dishwasher with Optional VaporGuard System

- VaporGuard Ventless System for hood-free operation
- Quad-Arm Wash System—washes faster with better results!
- INDUSTRY FIRST! Submerged booster recaptures radiant heat, saving energy and money
- Ergo-Grip door handle provides multiple options for hand placement and eliminates the need to modify dishtable for corner installation
- RackAware automatic rack sensing system only runs a cycle when a rack is in the machine—no wasted cycles
- Foot-operated drain pedal eliminates back strain
- Vertically mounted pump motor ensures consistent wash pressure

STANDARD FEATURES

- Capacity is 60 (20" x 20") racks per hour or 1500 dishes per hour
- 0.65 gallons per rack
- Oversized strainers collect twice the waste compared to traditional strainers
- Energy Conservation Drain Overflow reduces energy consumption
- Gas springs for smooth motion of hood and safe removal for replacement
- Hinged dishrack support swings up for tank and scrap screen access—makes cleaning a breeze!
- Swing out control panel—all components & 24V controls are accessible from the front of the machine
- IP67 controls with anti-vandal push buttons for durability & water resistance
- Multiple cycles: standard wash (1), extended wash (2), heavy soil (3)
- Dishrack guides nest & lock for storage
- Front mounted wash tank for easy cleaning
- Tank heat: electric immersion heater or steam injectors
- Single point electrical connection: motor, controls, heater and optional built-in booster (when selected as an option)
- Door safety switch
- Low water protection
- De-lime program for easy cleaning
- Easy-glide door
- Detergent connection provision
- S/S frame, legs and feet
- Wash arms with secured caps/pipe plugs to prevent loss
- Front mounted controls
- Non-proprietary parts

OPTIONS

- Extra high
- VaporGuard Condensation Removal System (Ventless)
- Extra high with VaporGuard Condensation Removal System
- False panel kit for corner installation
- Steam coil
- Steam booster
- Security package
- Plastic 20" x 20" racks (plate or silver)
- Drain quench system

SPECIFIER STATEMENT

Specified unit will be an Insinger CX20 high temp door type dishwasher with optional VaporGuard system. Features include VaporGuard condensation removal, oversized strainers, energy conservation overflow, hinged dishrack support, swing out control panel, IP67 waterproof controls with anti-vandal push buttons, submerged booster, easy glide door, low water protection, and 304 stainless steel construction.



Additional Information

Capacity Per Hour	60 racks 1500 dishes 2400 glasses
Tank Capacity	17.5 gallons
Booster Capacity	2.3 gallons
Motor Size	1.5 HP
Steam Consumption at 20 psi min.	11 lbs./hour tank 22 lbs./hour booster 40° rise 43 lbs./hour booster 70° rise
Final Rinse Peak Flow at 20 psi. min.	3.9 gallons/minute
Final Rinse Consumption at 20 psi min.	38.4 gallons/hour
Exhaust Hood Requirement	450 CFM
Peak Rate Drain Flow	35 gallons/minute
Water Inlet Temperature	110°F
Time Cycle	Cycle 1: Wash Time: 49 sec Rinse Time: 10 sec Total Cycle Time: 59 sec Cycle 2: Wash Time: 80 sec Rinse Time: 10 sec Total Cycle Time: 90 sec Cycle 3: Wash Time: 170 sec Rinse Time: 10 sec Total Cycle Time: 180 sec
Shipping Weight	400 lbs.

SPECIFICATIONS

CONSTRUCTION- Hood and tank constructed of 16 gauge type 304 S/S. Hood unit of all welded seamless construction. S/S frame, legs and feet. All internal castings are non-corrosive lead free nickel alloy or bronze.

DOOR- Single piece construction operating doors have finger tip control, balanced by externally mounted gas springs.

PUMP- Centrifugal type “packless” pump with a brass petcock drain. Construction includes ceramic seal and a balanced stainless steel impeller on a precision ground stainless steel shaft, extension or sleeve. All working parts mounted as an assembly and removable as a unit without disturbing pump housing. One 1.5 hp motor, standard horizontal C-face frame, drip proof, internally cooled with ball-bearing construction.

CONTROLS- Front mounted controls for easy access.

SPRAY SYSTEM- Wash and rinse spray systems made of type 304 stainless steel pipe threaded into cast hub assemblies. Upper and lower wash and rinse spray assemblies are removable without the use of tools.

WASH- Quad-Arms upper and lower with teflon sleeve bearing. Arms are precision designed for maximum wash coverage of ware.

FINAL RINSE- Rinse arms upper and lower with precision design pattern for maximum coverage of ware.

DRAIN- Foot pedal operated with auto-sense to indicate when drain is open.

Contact Insinger Sales at 800-344-4802 for an installation drawing specific to your application.
This drawing is available on the Insinger website at www.insingermachine.com

Note: Due to product improvement we reserve the right to change information and specifications without notice.

Technical Drawings

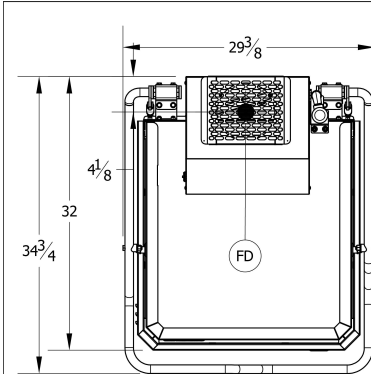

CX20 VG High Temperature Door Type Electrically Heated Dishwashing Machine with **VAPOR GUARD OPTION**

INSTALLATION CONNECTIONS		
	Description	Note
D	DRAIN CONNECTION	1-1/2 F-NPT
W1	HOT WATER INLET (110° F MIN.)	1/2 F-NPT
W2	COLD WATER INLET (70° F MAX)	1/2 F-NPT
E1	MAIN ELECTRICAL (SINGLE & 2-POINT)	1-3/8 HOLE
E2	BOOSTER ELECTRICAL (2 PT ONLY)	1-3/8 HOLE
FD	FAN DISCHARGE (VAPOR GUARD)	6" MIN. Clearance
CP	CONDUCTIVITY PROBE LOCATION	7/8 HOLE
DT	DETERGENT INSERSION POINTS	7/8 HOLE
RA	RINSE AID CONNECTION	1/4 F-NPT
C	CHEMICAL LINE & SIGNAL ACCESS	1/2 HOLES (4)

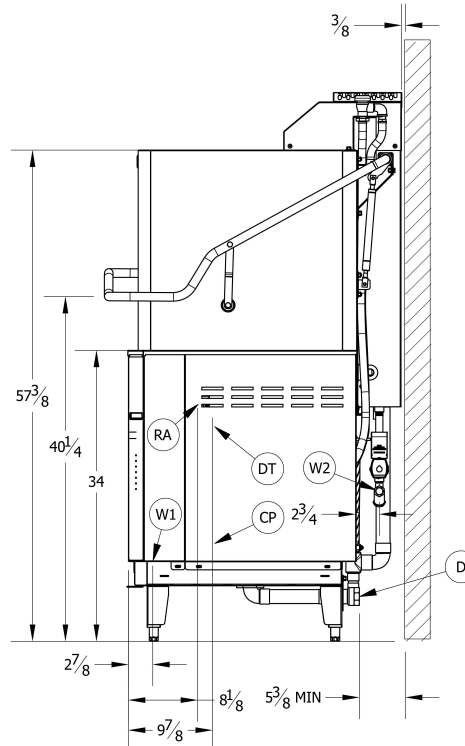
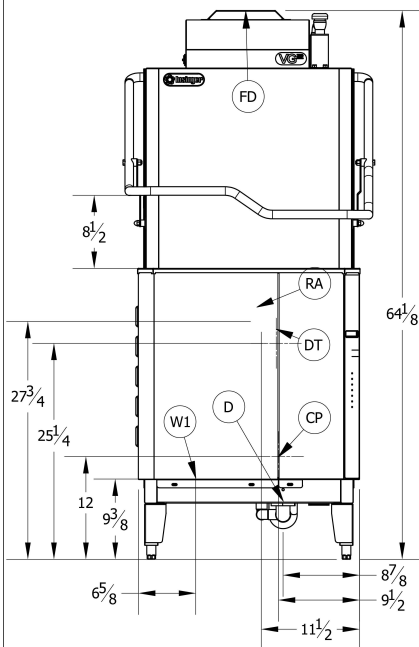

SPECIFICATIONS	
Racks per Hour	60
Dishes per Hour	1500
Glasses per Hour	2400
Wash Tank (gallons)	17.5
Booster Capacity (gallons)	2.3
Wash Motor HP	1.5
Final Rinse Consumption @ 20 psi (gal / hr)	38.4
Final Rinse Peak Flow @ 20 psi (gal/min)	3.9
Gallons per Rack @ 20 psi	.65
Vapor Guard Water Consumption @ 20 psi (gal/min)	4.0
Vapor Guard Water Consumption @ 20 psi (gal/cycle)	1.3
Peak Drain Flow (gpm)	35.0
Tank Heat (kW)	9.0
Booster Heat (kW)	9.0
Shipping Weight (lbs)	500

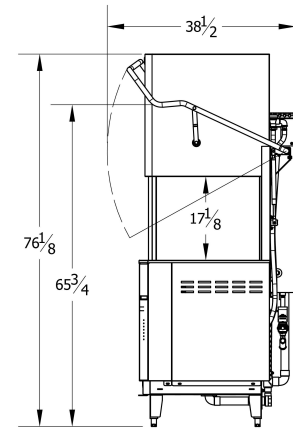

HEAT LOAD	BTU / Hr
LATENT HEAT	4046
SENSIBLE HEAT	8224
TOTAL HEAT	12720

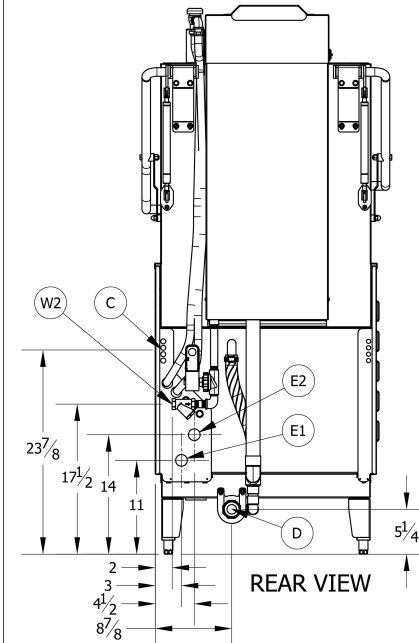

SINGLE POINT ELECTRICAL CONNECTION

Voltage	(E1) Rated Amps	(E1) Min. Circuit Ampacity / Max. Protective Device
208/60/3	54.0	70
240/60/3	47.8	60
480/60/3	23.8	30
208/60/1	96.1	125
240/60/1	84.3	110

DUAL POINT ELECTRICAL CONNECTION

Voltage	(E1) Rated Amps	(E1) Min. Circuit Ampacity / Max. Protective Device	(E2) Rated Amps	(E2) Min. Circuit Ampacity / Max. Protective Device
208/60/3	30.0	40	25.0	35
240/60/3	26.1	35	21.7	30
480/60/3	13.0	20	10.8	15
208/60/1	52.8	70	43.3	60
240/60/1	46.8	60	37.5	50

REV	CHANGE	DESCRIPTION	DATE	APPROVED
A	PROCESS	RELEASED TO PRODUCTION	2/28/2022	JSC

DESCRIPTION:
Spec Sheet, CX20 w/ Vapor Guard Option

DRAWN BY: JCalhoun	SHEET SIZE: A	PART NUMBER: 9200-03729	REV: AB
DATE: 1/13/2022			SHEET 1 of 1

Technical Drawings

STEAM BOOSTER

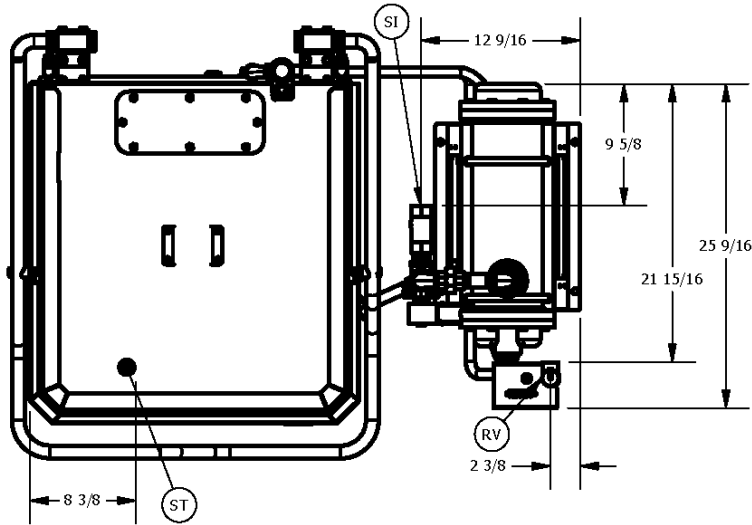
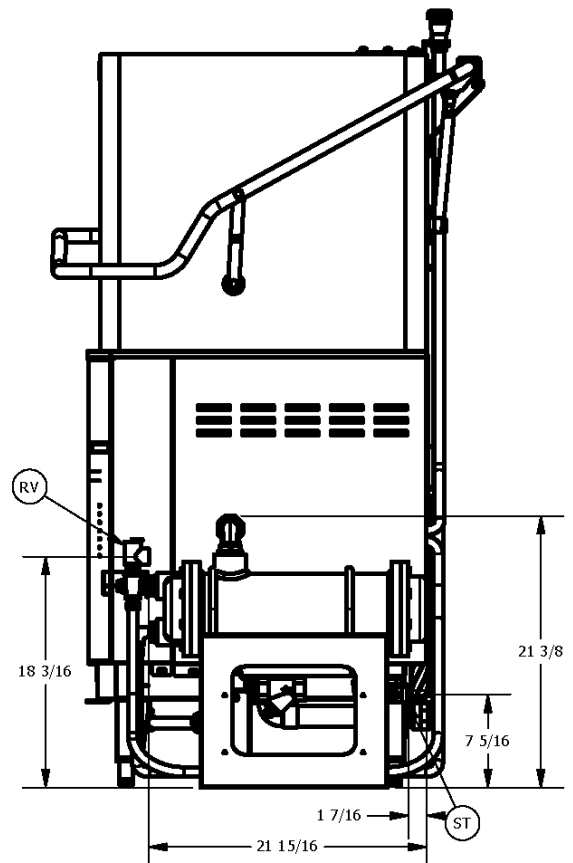
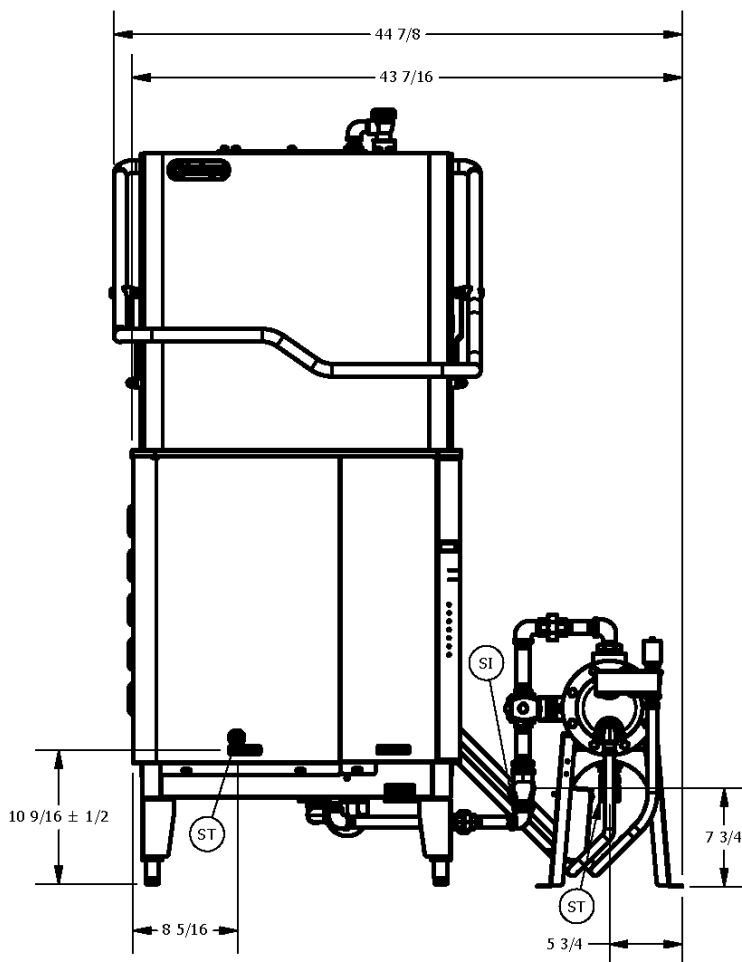

TABLE		
ITEM	DESCRIPTION	SIZE
SI	STEAM INLET	1 NPT
ST	STEAM TRAP OUTLET	1/2 NPT
RV	MAIN ELECTRICAL	3/4 NPT

ALL CONNECTION POINTS SHOWN APPLY TO BOTH STANDARD AND HIGH HOOD UNITS



Electrical Requirements

ELECTRICALLY HEATED / SINGLE POINT CONNECTION									
VOLTS	PHASE	FREQ	WASH MOTOR	WASH HEATER	RINSE HEATER	CONTROL	TOTAL LOAD	MCA	MOP
208	1	60	9.2 A	43.3 A	43.3 A	0.27 A	96.1 A	125 A	125 A
240	1	60	9.1 A	37.5 A	37.5 A	0.24 A	84.3 A	110 A	110 A
208	3	60	4.7 A	25.0 A	25.0 A	0.27 A	54.0 A	70 A	70 A
240	3	60	4.2 A	21.7 A	21.7 A	0.24 A	47.8 A	60 A	60 A
480	3	60	2.1 A	10.8 A	10.8 A	0.12 A	23.8 A	30 A	30 A

ELECTRICALLY HEATED / DUAL POINT CONNECTION															
CONNECTION #1									CONNECTION #2						
VOLTS	PH	FREQ	WASH MOTOR	WASH HEATER	CONTROL	TOTAL LOAD	MCA	MOP	VOLTS	PH	FREQ	RINSE HEATER	TOTAL LOAD	MCA	MOP
208	1	60	9.2 A	43.3 A	0.27 A	52.8 A	70 A	70 A	208	1	60	43.3 A	43.3 A	60 A	60 A
240	1	60	9.1 A	37.5 A	0.24 A	46.8 A	60 A	60 A	240	1	60	37.5 A	37.5 A	50 A	50 A
208	3	60	4.7 A	25.0 A	0.27 A	30.0 A	40 A	40 A	208	3	60	25.0 A	25.0 A	35 A	35 A
240	3	60	4.2 A	21.7 A	0.24 A	26.1 A	35 A	35 A	240	3	60	21.7 A	21.7 A	30 A	30 A
480	3	60	2.1 A	10.8 A	0.12 A	13.0 A	20 A	20 A	480	3	60	10.8 A	10.8 A	15 A	15 A

STEAM HEATED / SINGLE POINT CONNECTION							
VOLTS	PH	FREQ	WASH PUMP	CONTROL	TOTAL LOAD	MCA	MOP
208	1	60	9.2 A	0.31 A	9.5 A	15 A	15 A
240	1	60	9.1 A	0.26 A	9.4 A	15 A	15 A
208	3	60	4.7 A	0.31 A	5.0 A	15 A	15 A
240	3	60	4.2 A	0.26 A	4.5 A	15 A	15 A
480	3	60	2.1 A	0.13 A	2.2 A	15 A	15 A