



TECHNICAL MANUAL

Installation, Operation and Maintenance Instructions

TRAC 878

Tray Washer

Insinger Machine Company
6245 State Road
Philadelphia, PA 19135-2996

800-344-4802
Fax: 215-624-6966
www.insingermachine.com

Thank you for purchasing a quality Insinger product.

In the space provided below please record the model, serial number and start-up date of this unit:

Model: _____

Serial Number: _____

Start-Up Date: _____

When referring to this equipment please have this information available.

Each piece of equipment at Insinger is carefully tested before shipment for proper operation. If the need for service should arise please contact your local Authorized Insinger Service Company.

To find your local authorized Service Company please visit our web site, www.insingermachine.com or call Insinger at 800-344-4802.

For proper activation of the Insinger Limited Warranty, a SureFire™ Start-up should be completed on your machine. Refer to the Introduction section in this manual for an explanation of Insinger's SureFire™ Start-up and Check-out Program.

Please read the Insinger Limited Warranty and all installation and operation instructions carefully before attempting to install or operate your new Insinger product.

To register your machine for warranty, or for answers to question concerning installation, operation, or service contact our Technical Service Department.

TECHNICAL SERVICE CONTACTS	
Toll-Free	800-344-4802
Fax	215-624-6966
e-mail	service@insingermachine.com
Web site	www.insingermachine.com

TABLE OF CONTENTS

Part 1	1-4
Technical Information	
<ul style="list-style-type: none"> • Specification Sheets • Introduction • Definitions • Safety Summary • Warranty 	
Part 2	5-7
Installation Instructions	
<ul style="list-style-type: none"> • General Installation Instructions • Installation Drawings 	
Part 3	8
Operation Instructions	
Part 4	9
Cleaning Instructions	
<ul style="list-style-type: none"> • Daily Cleaning Instructions • Weekly Cleaning Instructions 	
Part 5	10-19
Maintenance and Repair Procedures	
<ul style="list-style-type: none"> • Maintenance Requirements • Maintenance Procedures • Troubleshooting 	
Part 6	20-48
Parts and Assemblies	
<ul style="list-style-type: none"> • Assembly Drawings with Parts Lists 	
Part 7	49-56
Electrical Schematics and Parts	
<ul style="list-style-type: none"> • Electrical Schematics • Control Panel Layouts 	



ESSENTIAL SERIES

Project _____
Item _____
Quantity _____
CSI - 11400 _____
Approval _____
Date _____

TRAC⁸⁷⁸

Automatic Triple Tank Tray Washer

- Automatic conveyor, triple tank tray washer with recirculating pre-wash, wash and rinse and fresh water final rinse.
- 197 gallons/hour final rinse consumption
- Capacity is up to 878 trays per hour (based on a 15" tray)



STANDARD FEATURES

- Tank heat: 15 kW electric immersion heater or steam injector
- Capillary thermometers for wash and rinse
- In-line thermometer for final rinse
- Vacuum breaker on all incoming water lines
- Manifold clean-out brush
- Vents with adjustable damper controls
- SureFire[®] Start-Up & Check-Out Service
- Single point electrical connection: motor, controls and tank heat (Booster requires a separate connection)
- Inspection door
- S/S frame, legs and feet
- S/S front enclosure panel
- Automatic tank fill
- Low water protection
- Detergent connection provision
- Top mounted NEMA 12 control panel
- Simplified scrap screen design
- Door safety switch
- Standard frame drip proof motors
- Override switch for de-liming
- End caps/pipe plugs secured to prevent loss
- Tray unload table

OPTIONS

- Stainless steel steam coil tank heat
- Steam booster
- Electric booster
- Pressure reduction valve and line strainer
- Security package
- Insulated hood and door
- Chemical sanitizer injector package for low temperature operations (pump by others)
- Tray Dryer
- Tray Stacker

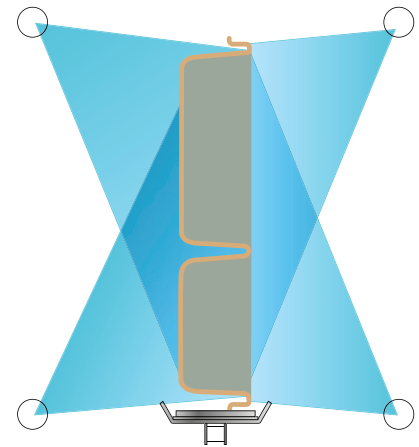

Insinger's traywashers were developed specifically to optimally clean and sanitize ware by reaching all corners and crevices with a vertical spray.





TRAC⁸⁷⁸ Automatic Triple Tank Tray Washer

Capacity Per Hour	878 trays
Tank Capacity	11.2 gallons (pre-wash) 15.3 gallons (wash) 11.5 gallons (rinse)
Motor Size	1/2 hp (pre-wash) 3 hp (wash) 2 hp (rinse) 1/8 hp (conveyor)
Electric Usage	8 kW wash tank 8 kW rinse tank 24 kW booster (40° rise) 36 kW booster (70° rise)
Steam Consumption at 20 psi min.	54 lbs./hour tank 70 lbs./hour booster 40° rise 122 lbs./hour booster 70° rise
Final Rinse Peak Flow at 20 psi min.	3.28 gallons/minute
Final Rinse Consumption at 20 psi min.	197 gallons/hour
Exhaust Hood Requirement	100 CFM Load 300 CFM unload
Peak Rate Drain Flow	23 gallons/minute
Shipping Weight	1100 lbs.

Machine Electrical*		
Motors, Controls, Tank Heat	Steam	Electric without booster
208/3/60	22.7	67.1
240/3/60	20.6	59.0
480/3/60	12.5	36.9
380/3/50	10.2	29.4

*Booster heater wired separately. Machine load only listed above.

SPECIFICATIONS

CONSTRUCTION- Hood and tank constructed of 16 gauge type 304 S/S. Hood unit of all welded seamless construction. S/S frame, legs and feet. All internal castings are non-corrosive lead free nickel alloy, bronze or S/S.

DOORS- Extra large die formed 18-8 type 304 S/S front inspection door riding in all S/S channels. A triple ply leading edge on the door channels made of S/S with no plastic or nylon sleeves or liners used. Two intermediate S/S door-safety stops on the door.

CONVEYORS- One S/S roller conveyor chain with tray cradles. Width between guide rails is factory-adjustable from 1.5" to 3.7". Conveyor accommodates trays up to 15" high. Conveyor drive system includes direct drive gear motor with frictionless, trouble-free overload release system continuously running. Trays conveyed automatically through washing and rinsing systems powered by independent conveyor motor.

PUMP- Centrifugal type "packless" pump with a brass petcock drains. Construction includes ceramic seal and a balanced cast impeller on a precision ground stainless steel shaft, extension or sleeve. All working parts mounted as an assembly and removable as a unit without disturbing pump housing. 2 hp wash motor standard horizontal C-face frame, drip proof, internally cooled with ball-bearing construction.

CONTROLS- Top mounted control cabinet, NEMA 12 rated with heat insulation provided between hood and control cabinet, housing motor controls and overload protection, transformer, contactors and all dishwasher integral controls. All controls safe low voltage 24 VAC.

ENERGY SAVER- Electric photo-eye automatically operates the final rinse solenoid only when a tray passes, saving water and energy. The eye also activates an adjustable timer control. If no tray passes during the set time, the machine shuts down.

SPRAY SYSTEM- Wash and final rinse spray systems are made of 18-8 type 304 stainless steel pipe. Wash assemblies removable without the use of tools.

WASH- Four wash arms threaded into S/S manifold. (2 on each side of conveyor). Each pipe designed with 8 high pressure action cleansing slots. The slots are precision milled for water control producing a fan spray.

FINAL RINSE- Eight nozzle assemblies on either side of conveyor threaded into S/S pipes. Nozzle assemblies produce a fan spray reducing water consumption, maximizing heat retention.

DRAIN- Drain valve externally controlled. Overflow assembly with skimmer cap is removable without the use of tools for drain line inspection. Heater is protected by low water level control.

UNLOAD TABLE- a stainless steel tray unload table receives clean trays. Table constructed with guide rails which ease the trays onto table.

TRAC 878 TRAYWASHER

INTRODUCTION

This manual contains all pertinent information to assist in the proper installation, operation, cleaning, maintenance, and parts ordering for the TRAC 878 traywasher.

The installation instructions are intended for qualified equipment installers.

The operation and cleaning instructions are intended for the daily users of the equipment.

The maintenance and drawing sections are intended for qualified service and/or maintenance technicians.

Replacement parts may be ordered directly from our factory or from your local Authorized Insinger Service Company.

Surefire™ Start-Up Program

Insinger is proud to offer our exclusive Surefire™ Start-up & Check-out Program to our commercial customers. This service is included in the purchase price of your new Insinger dishwasher. We will provide an authorized factory service technician for the initial start-up of your new Insinger dishwasher to ensure it is running correctly. Please call the factory or your local Insinger Sales or Service Representative to schedule this service.

NSF 3 requirements for detergent and chemical sanitizer dispensers

This machine must be operated with an automatic detergent feeder and, if applicable, an automatic chemical sanitizer feeder, including a visual means to verify that detergents and sanitizers are delivered or a visual or audible alarm to signal if detergents and sanitizers are not available for delivery to the respective washing system. Please see instructions for electrical and plumbing connections located in this manual and in the feeder equipment manual.

Intended Use

The Insinger traywashers may only be used for cleaning institutional trays.

Any change in design or use of the dishwasher carried out without the written permission of Insinger, will lead to warranty nullification.

If damage is caused to the dishwasher due to failure to observe the instructions given in this manual, no claims under the warranty agreement can be submitted to Insinger Machine Company.

DEFINITIONS



Throughout this guide you will find the following terms: **WARNING, CAUTION, & NOTE.**

WARNING indicates potential physical danger.

CAUTION indicates potential equipment damage.

NOTE indicates helpful operating hints or tips.

You will visually be able to identify each as shown below:

	WARNING: Indicates potential physical danger.
CAUTION:	
Indicates potential equipment damage.	
	NOTE: Indicates helpful operating hints or tips.

SAFETY SUMMARY

The following are general safety precautions that are not related to any specific procedures. These are recommended precautions that personnel must understand and apply during many phases of operation and maintenance.

Keep Away From Live Circuits

Operating personnel must at all times observe all safety regulations. Do not replace components or make adjustments inside the equipment with the power supply turned on. Under certain conditions, dangerous potentials may exist when the power control is in the off position. To avoid casualties and injuries, always remove power, red tag and lockout machine, and ground a circuit before touching it.

Do Not Service or Adjust Alone

Under no circumstances should any person reach into or enter the enclosure for the purpose of servicing or adjusting the equipment except in the presence of someone who is capable of rendering aid.

Resuscitation

Personnel working with or near high voltages should be familiar with modern methods of resuscitation. Such information may be obtained from the Bureau of Medicine and Surgery.

INSINGER MACHINE COMPANY LIMITED WARRANTY

Insinger Machine Company, Inc. (Insinger) hereby warrants to the original retail purchaser of this Insinger Machine Company, Inc. product, that if it is assembled and operated in accordance with the printed instructions accompanying it, then for a period of either 15 months from the date of shipment from Insinger or 1 year (12 months) from the date of installation or start-up that said Insinger product shall be free from defects in material and workmanship. Whichever one of the two aforesaid limited warranty time periods is the shortest shall be the applicable limited warranty coverage time period.

Insinger may require reasonable proof of your date of purchase; therefore, you should retain your copy of invoice or shipping document.

This limited warranty shall be limited to the repair or replacement of parts which prove defective under normal use and service and which on examination shall indicate, to Insinger's satisfaction, they are defective. Any part that is claimed to be defective and covered by this limited warranty must be returned to Insinger. An RMA# must be obtained from the Insinger Warranty Department before returning any material. Return may be done through an Authorized Service Agency. Furnish serial number of machine and RMA # with shipment and send to:

Insinger Machine Company
6245 State Road
Philadelphia, PA 19135-2996

If Insinger's inspection confirms the defect and the claim, Insinger will repair or replace such part without charge and return it to you freight or postage prepaid.

This limited warranty does not cover any failure or accident, abuse, misuse, alteration, misapplication, improper installation, fire, flood, acts of God or improper maintenance or service, or failure

to perform normal and routine maintenance as set out in the instruction booklet (operating instructions) or for improper operation or failure to follow normal operating instructions (as set out in the instruction booklet). Insinger is not responsible nor liable for any conditions of erosion or corrosion caused by corrosive detergents, acids, lye or other chemicals used in the washing and or cleaning process.

Service must be done by either Insinger Appointed Service Agencies or agencies receiving prior authorization from Insinger.

All warranty work must be done during normal working hours, unless purchaser receives prior authorization from Insinger.

There are no other express warrants except as set forth herein and any applicable implied warranties of merchantability and fitness are limited in duration to the period of coverage of this express written limited warranty. This limited warranty supersedes all other express warranties, implied warranties of merchant-ability and fitness or limited warranties as of this date, January 1, 1998. Some states do not allow limitation on how long an implied warranty lasts so this limitation may not apply to you.

Insinger is not liable for any special, indirect or consequential damages. Some states do not allow the exclusion or limitation of incidental or consequential damages, so this limitation nor exclusion may not apply to you.

Insinger does not authorize any person or company to assume for it any other obligation or liability in connection with the sale, installation, use, removal, return or replacement of its equipment: and no such representations are binding on Insinger.

TRAC 878 TRAYWASHER INSTALLATION INSTRUCTIONS

These installation instructions are intended for qualified equipment installers.

PLACEMENT

Carefully uncrate the machine. Take caution not to damage components which may be mounted on the top or sides of the machine.

Set the unit in place and adjust the feet to level the machine.

TABLING

Load and unload tables should be pitched towards the machine to return excess water into the machine.

Fasten the tables to the load and unload side of the machine. Most installations require fastening the turn-down lip of the dish tables to the side of the machine with flathead countersunk screws.

The table design should provide horizontal clearance of 30" for servicing. Install rack guides on exit table using mounting studs provided.

ELECTRICAL CONNECTIONS

Connect electrical lines sized for the correct voltage, current and phase of the machine. These should agree with the machine requirements indicated on the nameplate and labels on the control panel.

Machines not provided with a single-point connection require two separate electrical connections for:

1. pumps and control circuit
2. wash tank heater(s)

If an electrical booster is provided, connect the booster directly to power source.

CAUTION:

Connections must be made to a circuit breaker or fused disconnect as provided by the end-user and required by local codes. A laminated wiring diagram is inside the control panel.

CAUTION:

As with any 3 phase system, an electrician must check all motors for proper phasing, i.e., Pump motors must be running in direction indicated by arrow on housing.

MECHANICAL CONNECTIONS

All lines must be flushed prior to use to remove debris.

Connect a 110°F (for 70°F rise) or a 140°F (for 40°F rise) water line for tank fills and booster as tagged and noted on the installation drawings.

If machine is provided with steam heat connect the steam lines and steam condensate lines as tagged and noted on installation drawings.

Connect the drain lines. Drain lines must be as specified on installation drawings.

If a booster is provided, a 110°F (for 70°F rise) or a 140°F (for 40°F rise) water connection is necessary. A steam booster also requires a condensate line.

CAUTION:

Drain lines must be as specified on installation drawings. Drain line should be properly vented and should have fall of not less than 1/4" to the foot of proper flow.

CAUTION:

Some area plumbing codes require drains to flow into an open gap with an opening twice the diameter of the pipe. Check with your local plumbing codes for the type of drain connection required.

CAUTION:

Do not reduce the size of lines as specified in installation drawings. All lines are sized to facilitate necessary flows, pressures, etc.

HVAC

Ventilation system should be sized to provide adequate ventilation per machine specs. Refer to spec sheet.

Stainless steel, watertight ducting should be connected to the vent cowls on each end of the machine. Refer to spec sheet and installation drawing.

CHEMICALS

Upon completed installation of the traywasher, contact a local detergent/chemical supplier for the correct chemicals for your machine.

Electrical connection points for the detergent dispenser and rinse injector are located inside the control panel. Refer to the machine wiring diagram for the proper connection points.

Dispensers may be connected on either the primary voltage side of the machine or the 24VAC control voltage side.

The detergent density probe should be placed in the hole provided.

CAUTION:

When connecting on the 24VAC control voltage side of the transformer, total KVA must not exceed 50VA.

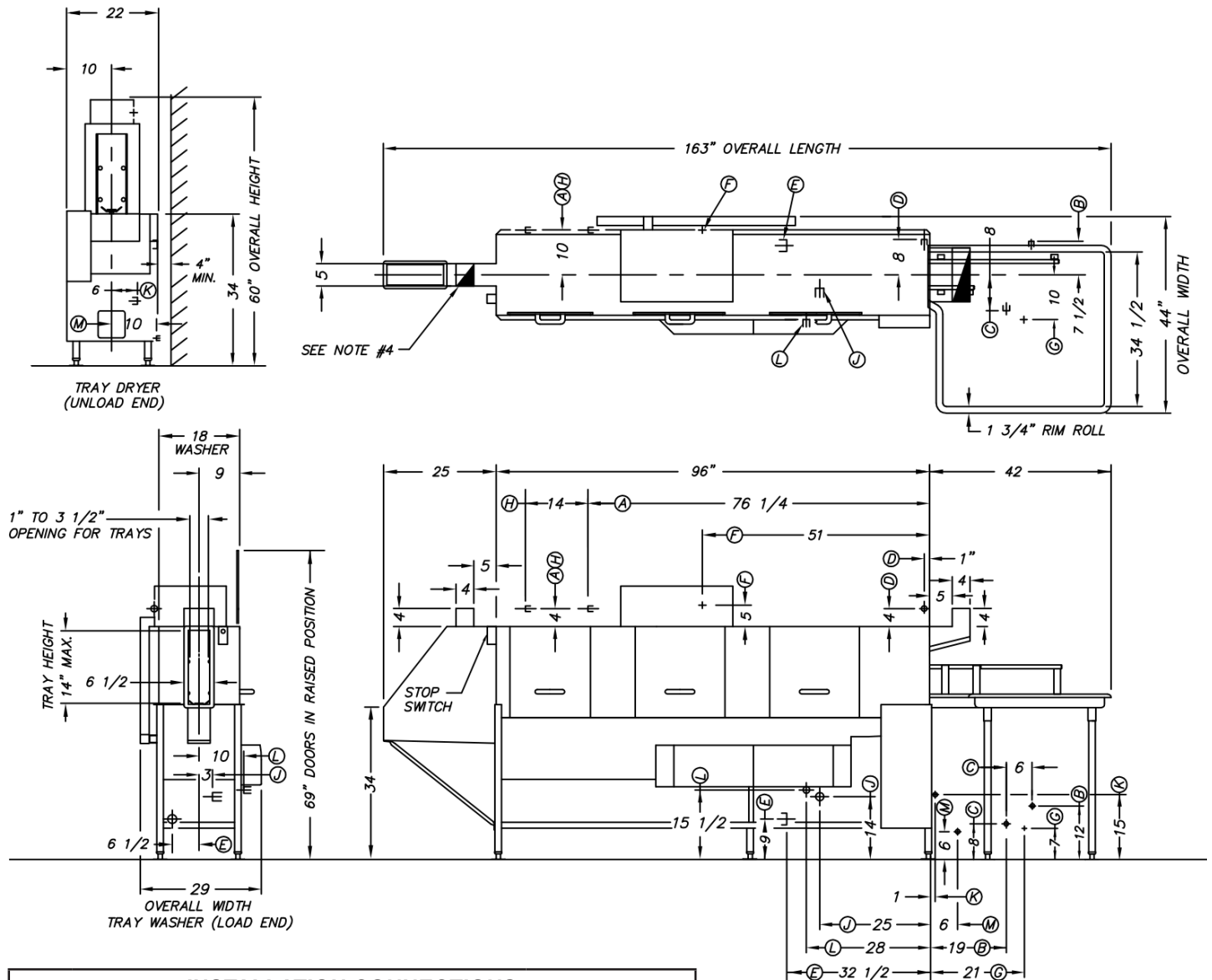
Installation Drawing : TRAC 878 (Left to Right Feed)

INSTALLATION CONNECTIONS

LTR	DESCRIPTION	SIZE
A	Hot Water to Auto Fill - 110°F	1/2" FIPS
B	Hot Water to Steam Booster - 110°F/140°F	1/2" FIPS
C	Hot Water to Electric Booster - 110°F/140°F	1/2" FIPS
D	Hot Water to Final Rinse - 180°F	1/2" FIPS
E	Drain Connection - Common	1 1/2" FIPS
F	Electric Service - 16kW + 5.6 HP	67.1 FLA
G	Electric Service - Booster 36 kW	101 FLA
H	Cold Water - PW Tempering	1/2" FIPS
J	Steam to Tanks	3/4" FIPS
K	Steam to Steam Booster (40° or 70°)	1/2" or 1" FIPS
L	Condensate Return - Coils Only	1/2" FIPS
M	Condensate Return - Steam Booster	1/2" FIPS

NOTES:

1. Electrical Voltage: 208V/3PH/60Hz. Total Amp Draw is 168.1 FLA.
2. Totally enclosed motors furnished.
3. Stainless Steel Frame, Legs, Tray Unload Furnished.
4. Vents 4 x 12 (500CFM) & 4 x 5 (50CFM) with Adjustable Dampers Furnished at Ends of Washer.

REV A - 09/03/01

TRAC 878 TRAYWASHER**OPERATION INSTRUCTIONS**

These instructions are intended for the daily users of this machine.

PREPARING MACHINE

1. Place drain overflow tube in drain basket. Close all tank drain valves. One drain is provided for each tank of the traywasher.
2. Check for proper installation and cleanliness of all internal, removable components such as suction strainers, scrap screens, and spray manifolds.
3. Ensure all water and steam lines are open.
4. Ensure electrical circuits are on.
5. Close machine doors.

**NOTE:**

An interlock is provided to shut the machine down if the doors are open, therefore the machine will not run if doors are opened. Machines provided with the optional Security Package do not have this feature.

STARTING MACHINE

1. Move the power switch to the "ON" position. The power light will illuminate. The tank(s) will automatically fill. When the tanks are full the tank heat will operate automatically.

**NOTE:**

To ensure proper operation of the auto tank fill feature and the tank heaters, the level float located in each tank **MUST** be cleaned daily.

2. Press the GREEN button to start the pumps and conveyor.
3. The system is now ready for operation. All ware should be properly scrapped.

WASHING A TRAY

1. Place the tray on the conveyor belt. The tray will pass through the machine cycles.

**NOTE:**

The photo-eye located at the entrance chute of the machine should be cleaned daily of lime build-up for proper operation of the energy saver feature and the final rinse.

SHUTDOWN

1. Press the RED stop button to turn the pumps and conveyor OFF.
2. Move the Power toggle switch to the "OFF" position.
3. Drain the machine.

CAUTION:

Ensure the Power toggle switch is in the "OFF" position before draining the machine.

4. Refer to the CLEANING INSTRUCTIONS for proper clean-up of the dishmachine.
5. Report any unusual occurrences to qualified service personnel.

**TRAC 878 TRAYWASHER
CLEANING INSTRUCTIONS**
DAILY CLEANING

The following cleaning procedures should be done daily, at the end of the shift:

1. Remove all internal removable parts including spray manifolds, scrap screens, drain overflow tubes, suction strainers and curtains.
2. Remove the end caps from the spray manifolds and clean with the brush provided. Flush the manifolds.
3. Flush scrap screens of matter.
4. Clean drain overflow tube.

CAUTION:

V-cup seal on the drain overflow tube may become gummed which will not allow the overflow tube to seat properly. This will cause the drain to leak water. Remove any build-up on the V-cup seal. When the seal becomes worn, replace.

5. Clean suction strainers of build-up.

CAUTION:

Improper cleaning of suction strainers will cause the pumps to cavitate. This will cause poor washing results.

6. Clean tank level floats (1 per tank) with a plastic abrasive pad. DO NOT use steel wool.

CAUTION:

Level floats must be cleaned daily. Build-up of grease and scum will cause faulty operation of tank fill and heating system.

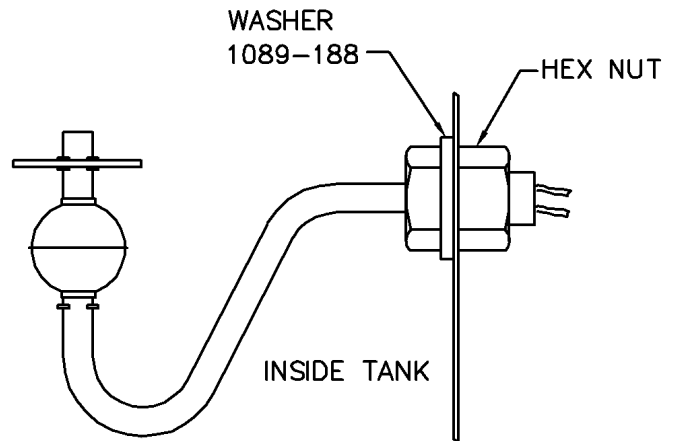

DE5-60: Liquid Level Float

7. Clean curtains. When curtains are beyond cleaning or torn they should be replaced.
8. Final rinse nozzles should be cleaned of matter.
9. Clean the photo-eye lenses with a damp, soft cloth.
10. Doors should be left open to allow drying of interior surfaces.

WEEKLY CLEANING

1. The entire machine should be wiped down using an industrial grade stainless steel cleaner.
2. Under the supervision of your detergent supplier the machine interior must be properly de-limed.

NOTE:

The water quality in some areas requires de-liming to be done more frequently. Contact your detergent supplier for recommended de-liming frequency.

TRAC 878 TRAYWASHER

MAINTENANCE REQUIREMENTS

This section is intended for qualified service and/or maintenance technicians.

The following maintenance should be conducted quarterly:

1. Remove and clean the strainer screens on water and steam lines. If the screens cannot be cleaned, replace.
2. Inspect the condition of the fill solenoid valve seats and diaphragms. Replace as necessary.
3. Inspect drain O-Rings for leakage. Replace where necessary.
4. Adjust conveyor chain tension using adjustment bolts located at machine entrance chute.

MAINTENANCE PROCEDURES

Solenoid Valve Disassembly (SK-5825)

1. Disconnect the power supply to the machine.
2. Turn off the water supply.
3. Remove cap on top of the coil. Remove the coil.
4. Remove the 4 hex bolts and lift bonnet from valve body. Note positioning of spring and plunger.
5. Remove main piston.
6. Inspect for dirt, wear or lime build-up. Clean or replace as required.
7. Reassemble in reverse of disassembly.

Line Strainer Disassembly

1. Shut off water supply.
2. Remove large hex nut on bottom of strainer body.
3. Remove strainer screen. Inspect and clean or replace as necessary.
4. Reassemble in reverse of disassembly. Water flow must be same direction as arrow on line strainer body. Use new gaskets to insure a tight seal.

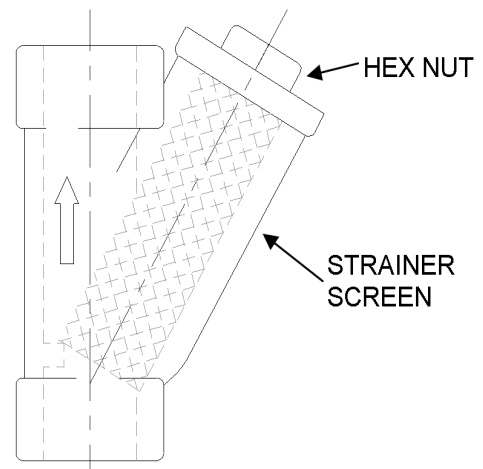

Line Strainer Assembly

Pump Disassembly

1. Before disassembling pump ensure there are no obstructions in the pump intake by removing and cleaning the suction strainer (inside tank).



NOTE:

It is not necessary to remove the pump housing from the machine to disassemble the pump.

2. Remove the pump motor and impeller adaptor by removing the 4 hex bolts attaching them to the pump housing.
3. Repair or replace the pump parts as required.
4. Reassemble in reverse of disassembly.

Final Rinse

The final rinse is actuated by a photo-eye located on the entrance chute (not used on machines with the security package option). As a tray passes the photo-eye the beam is broken. The Final Rinse timer (P/N DE7-27) will energize the final rinse solenoid. The final rinse water will then flow.

The Energy Saver timer (P/N DE7-28) is also reset keeping the machine running.

Both timers are adjustable by turning the potentiometer located on the timer board. The final rinse timer is adjustable between 0-60 seconds. The energy saver timer is adjustable between 0-300 seconds.

Tank Heat Temperature Adjustment

A temperature control board is provided in the control panel for easy adjustment of tank temperature. Though tank temperature is set during factory testing it is sometimes necessary to re-adjust the temperature at start-up.

1. Locate the temperature control board (P/N DE9-251). Use the Control Panel Layout drawing located in PART 7, Electrical Schematics and Parts.
2. Adjust the tank temperature to the correct temperature by turning the potentiometer located on the temperature control board. An arrow on the potentiometer indicates increase.



NOTE:
 Correct temperatures are:
 Prewash - below 140°F
 Wash - minimum 150°F
 Final Rinse - 180°F to 195°F

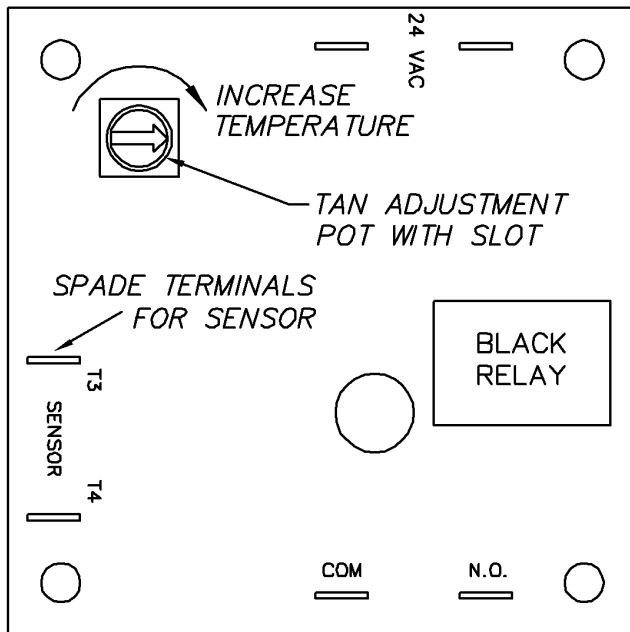

DE9-251: Tank Temperature Control Board

Troubleshooting Tank Temperatures

If the temperature does not change follow the below procedures.

Electric Heat:

1. Check the temperature control board (P/N DE9-251) for proper operation. If the temperature control board is faulty, replace.
2. Verify tank heat contactor is working correctly. If not, replace.
3. Verify all immersion heaters are working properly and are not limed. If not, replace.

Steam Heat:

1. Check the temperature control board (P/N DE9-251) for proper operation. If the temperature control board is faulty, replace.
2. Verify steam pressure per machine specifications.
3. Verify steam trap is not clogged. If so, clean and/or replace.

Immersion Heater Replacement (SK-4703)

1. The immersion heater **MUST** be completely submerged at all times. If this is not the case contact a qualified service technician. The heated surface should never be in contact with sludge.
2. Remove the housing covering the wiring terminations. Disconnect the immersion heater wires.
3. Remove the immersion heater by loosening and removing the large hex nut.
4. Install in reverse of removal.



NOTE:
 Use plumbers putty as gasketing around the immersion heater installation nut.

Motor Overloads

All motors used on Insinger Machines are provided with motor overloads. Motor overloads are adjusted when the machines are factory tested. Should it be necessary to adjust the motor overloads in the field first verify the motor current draw for the voltage the machine is using.

Refer to the Control Panel Layout drawing located in PART 7 to identify the overload, adjust by turning the dial to the appropriate AMP draw.

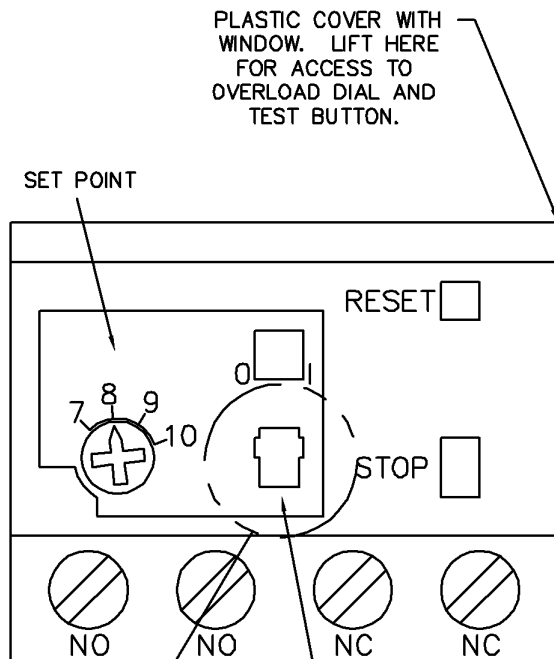

RESET SELECTOR WINDOW (AUTO RESET MODE SHOWN)

TO CHANGE FROM MANUAL TO AUTO RESET:

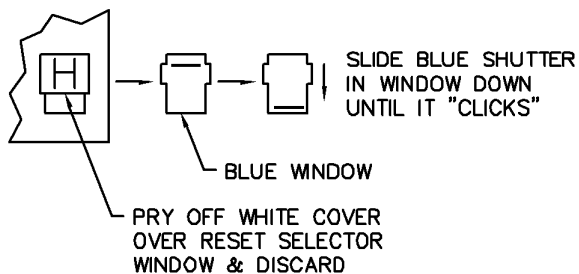

Motor Overload Relay

Level System

The level control system consists of one level timer (P/N DE7-35) and one level float (P/N DE5-60) in the wash tank and one level float (P/N DE5-60) in the prewash tank.

When the system is powered-up, the tank(s) will begin to fill (assuming no water is in the tanks).

Once the level float is actuated, the timer begins to time-out and continues the filling process until the tank(s) is full.

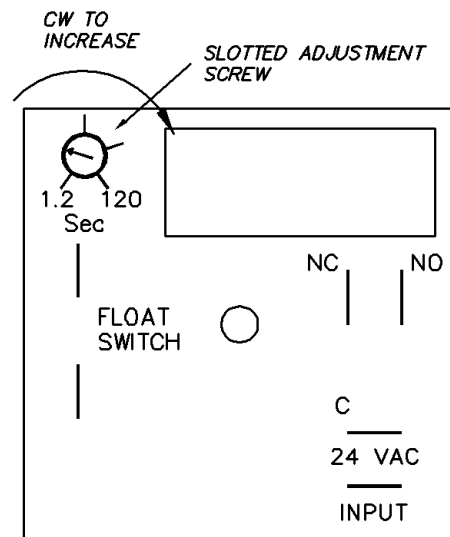

DE7-35: Liquid Level Timer

CAUTION:

Dirty level floats will cause the tank heat to energize with no water in the tanks. Level floats MUST be cleaned daily.

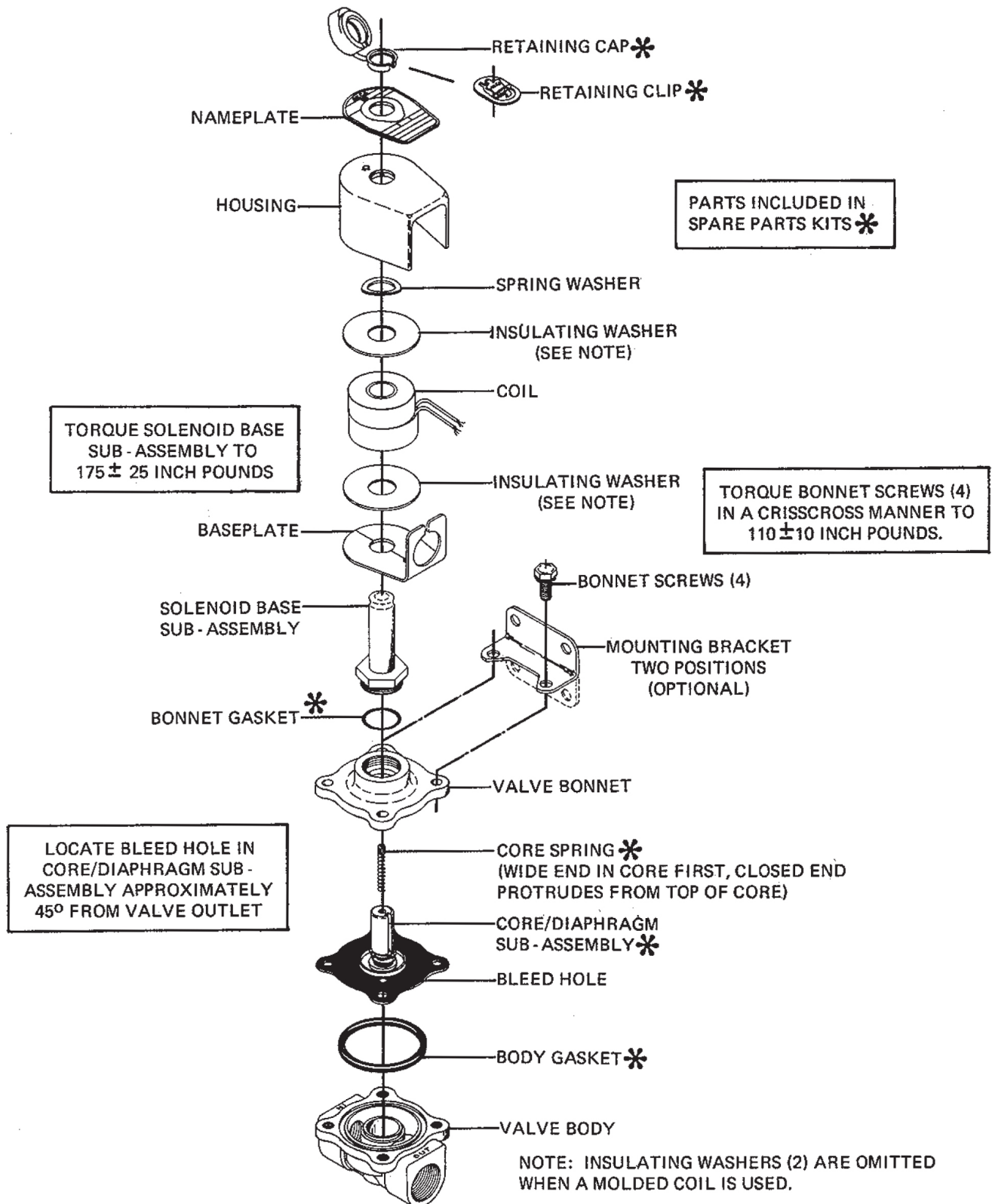
SK-5825 : Final Rinse Solenoid Valve

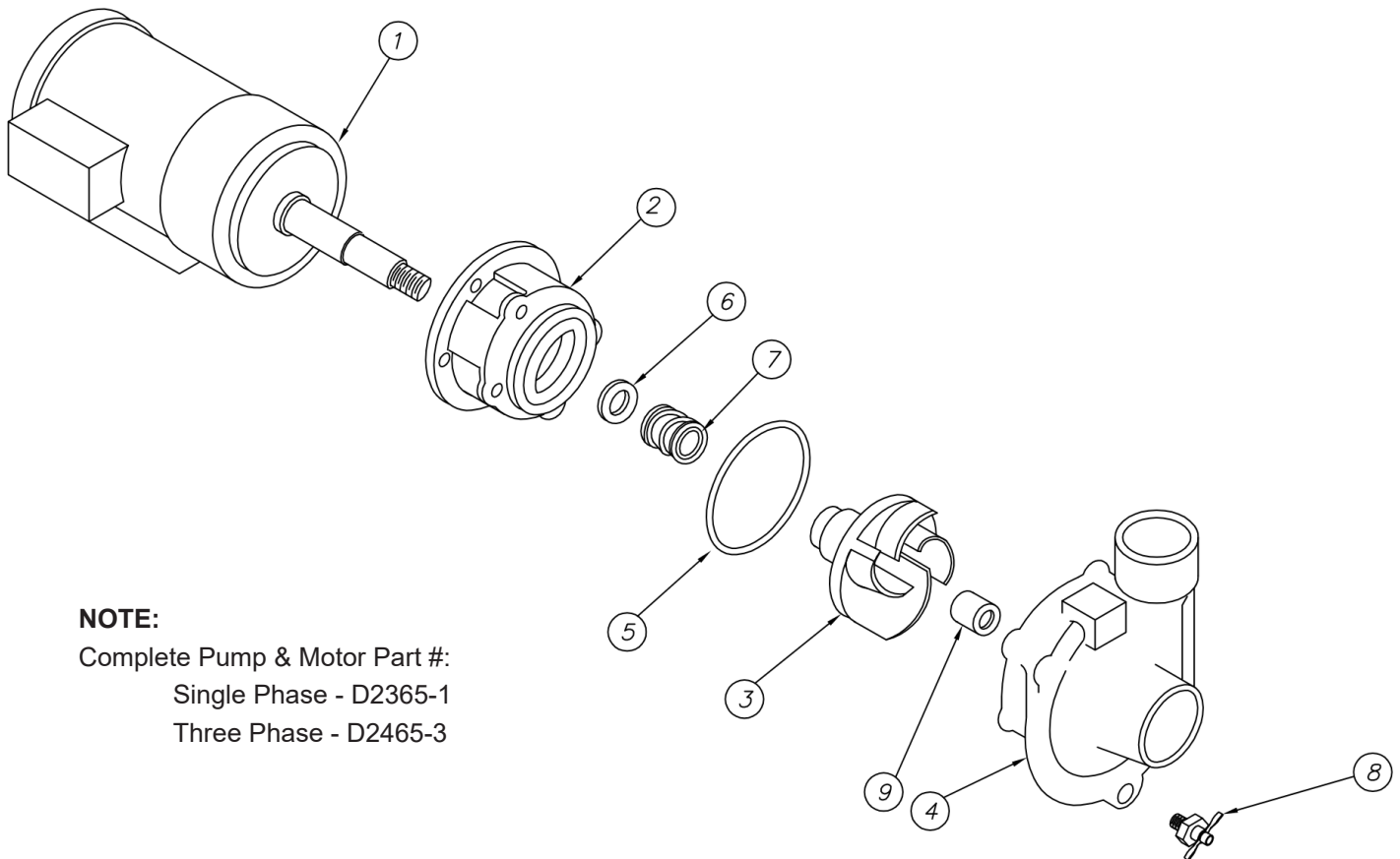

NOTE:

Complete Pump & Motor Part #:
 Single Phase - D2365-1
 Three Phase - D2465-3

REV C - 03/25/04

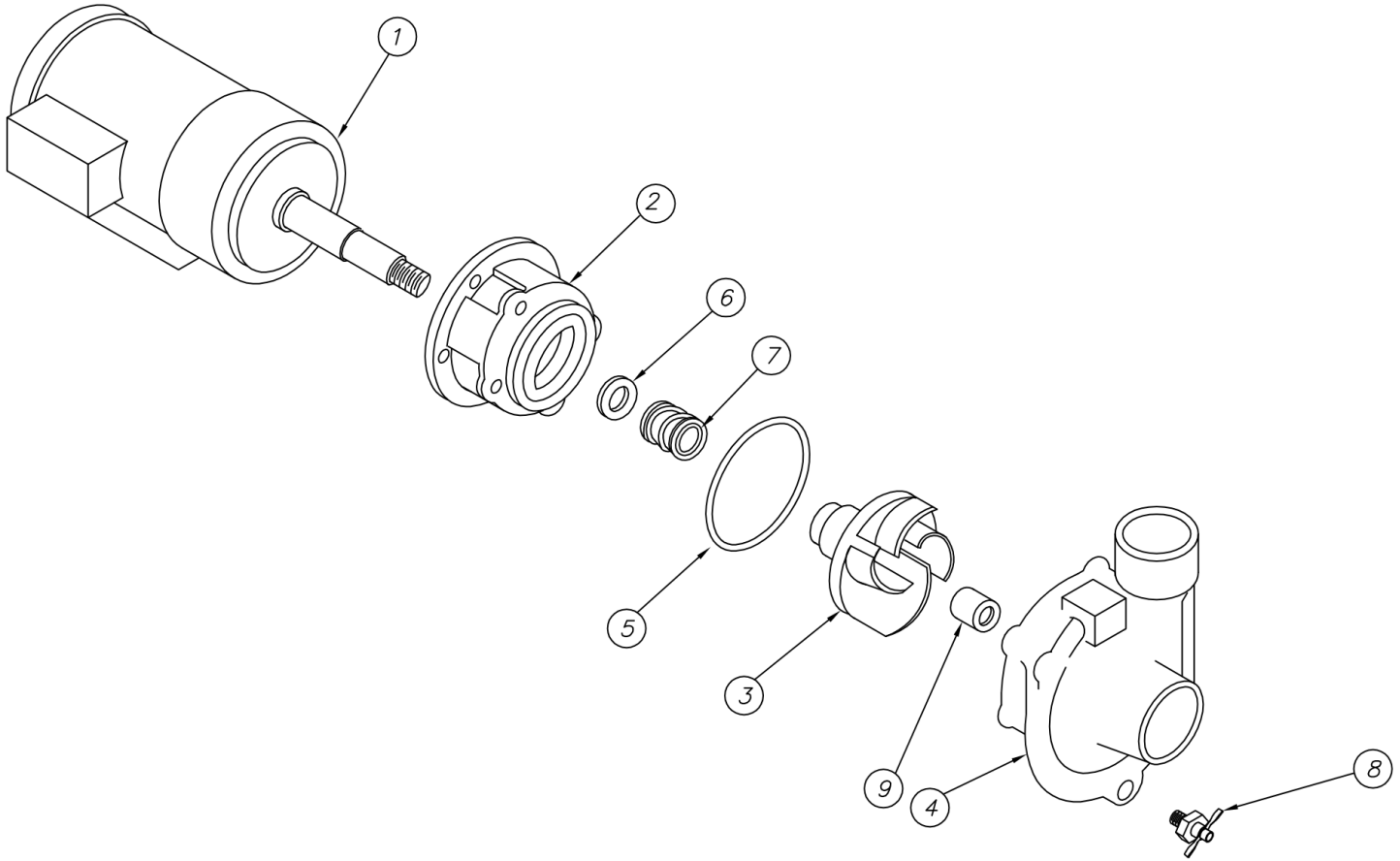
ITEM	PART NO.	DESCRIPTION	QTY
1		Motor 1 HP	1
2	D431	Adapter	1
3	D436	Impeller 3 7/8"	1
4	D434	Casing	1
5	D2-532	O-Ring	1
6	D2-533	Flinger	1
7	D2-534	Seal Assembly	1
8	D329-5	Drain Petcock 1/4" IPS	1
9	D3-808	Impeller Retaining Nut	1



REV C - 03/08/18

ITEM	PART NO.	DESCRIPTION	QTY
1		Motor 2 HP	1
2	D431	Adapter	1
3	D443	Impeller 4 3/8"	1
4	D434	Casing	1
5	D2-532	O-Ring	1
6	D2-533	Flinger	1
7	D2-534	Seal Assembly	1
8	D329-5	Drain Petcock 1/4" IPS	1
9	D3-808	Impeller Retaining Nut	1

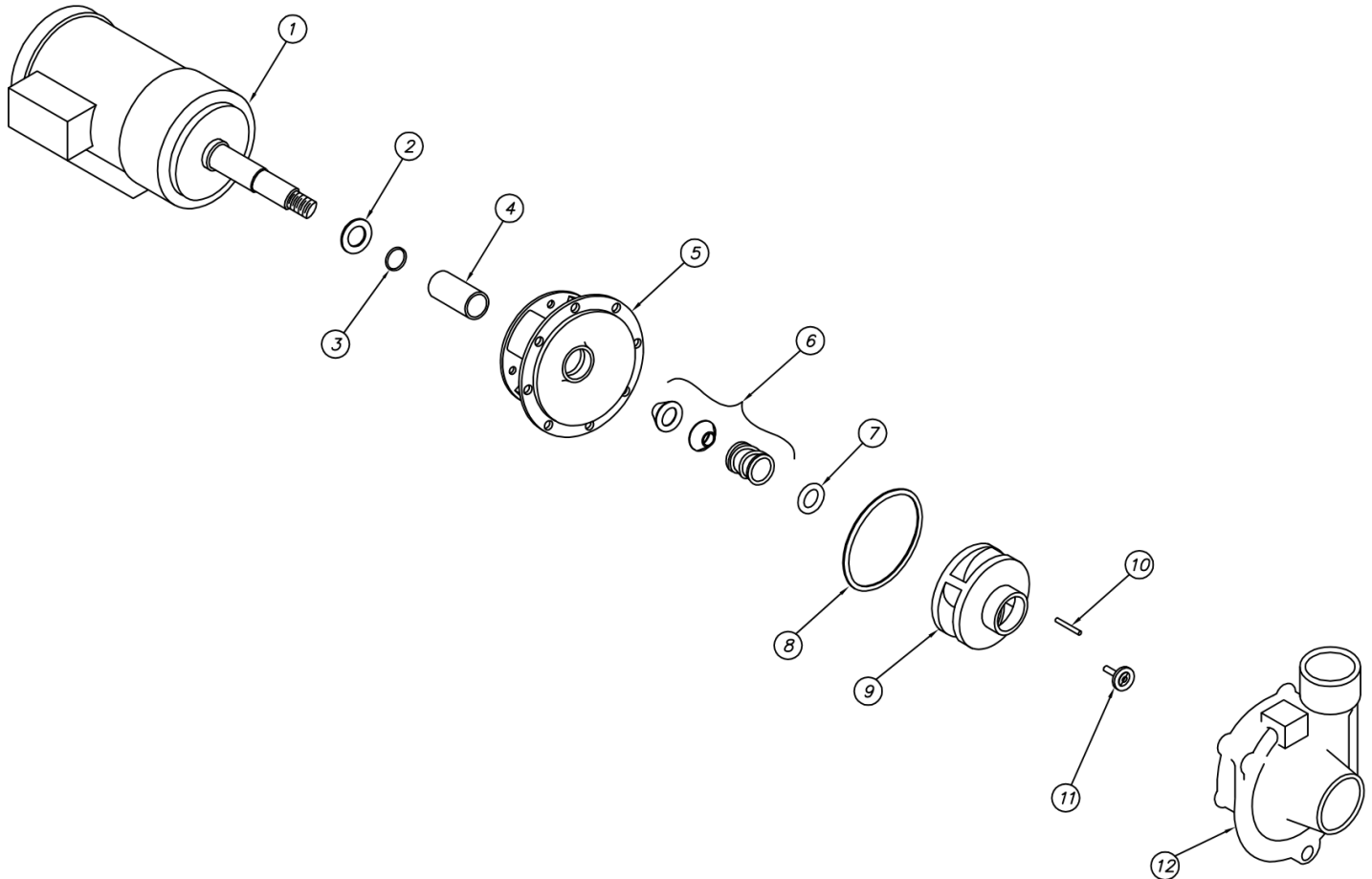

REV A - 06/06/06

ITEM	PART NO.	DESCRIPTION	QTY
1		Motor 3 HP	1
2	104.000.165	Flinger	1
3	116.000.117	O-Ring, Shaft	1
4	110.000.178	Shaft Sleeve, Bronze	1
5	132.000.194	Adapter, Iron - JM140/180	1
6	101.000.168	Seal, 1 1/2"	1
7	104.000.175	Seal Retainer	1
8	116.000.146	Gasket, Case	1
9	-	Impeller, 4 3/4"	1
10	102.000.102	Key	1
11	118.000.111A	Impeller Retainer	1
12	130.000.169	Case	1

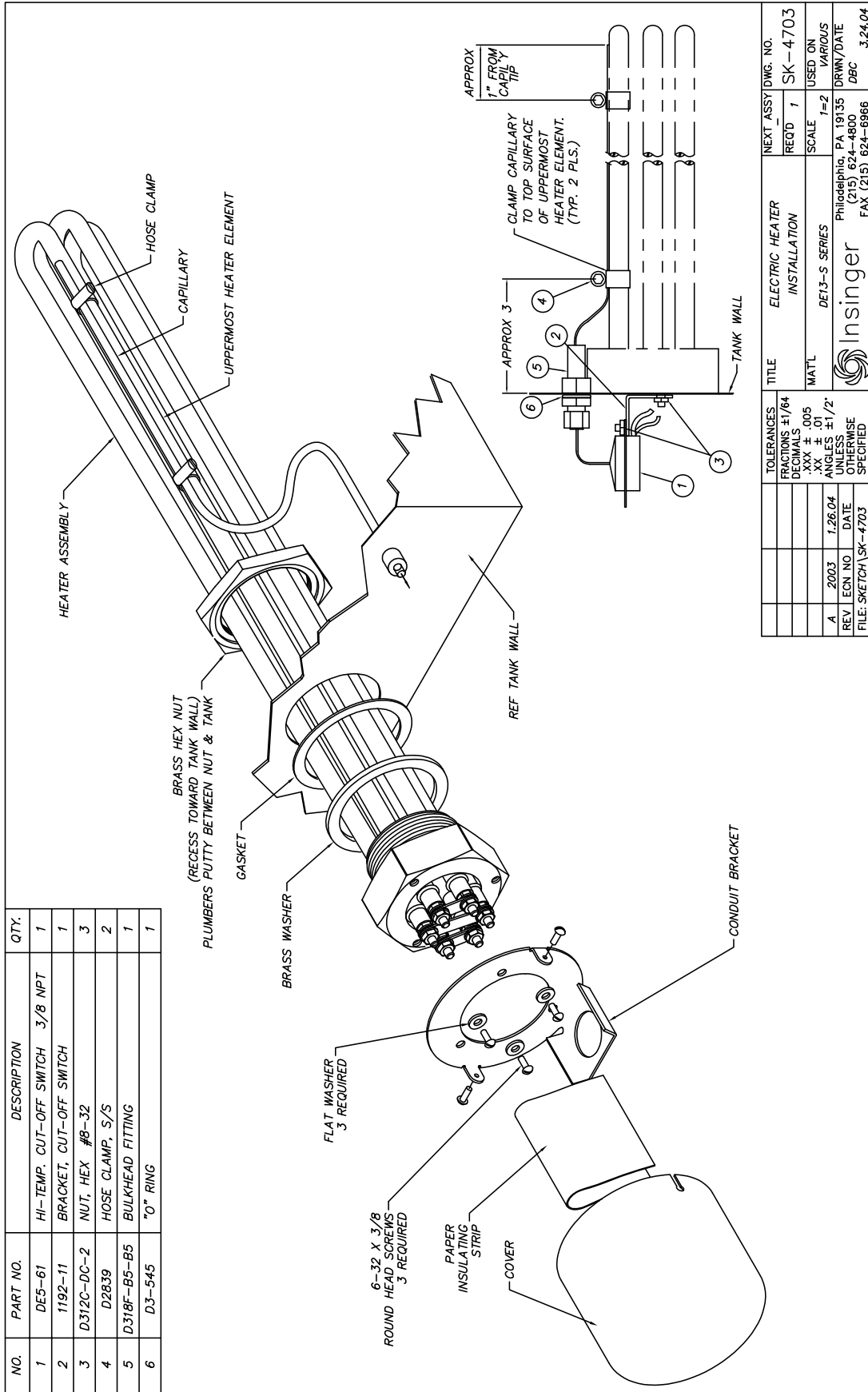
SK-4703 : Electric Heater Installation

TROUBLESHOOTING

TECHNICAL ISSUES	POSSIBLE CAUSES	SOLUTIONS
Machine will not operate	<ol style="list-style-type: none"> 1. No power 2. Blown fuse or tripped breaker 3. Motor overloads tripped 	<ol style="list-style-type: none"> 1. Check power supply 2. Replace fuse; reset breaker 3. Reset overload
Tank will not hold water	<ol style="list-style-type: none"> 1. Drain not closed 2. Drain overflow not seated or installed 3. Pump petcock opened 4. Overflow v-seal dirty/worn 	<ol style="list-style-type: none"> 1. Close drain 2. Reseat or install drain overflow 3. Close pump petcock 4. Clean/replace v-seal
Tank fills beyond overflow	<ol style="list-style-type: none"> 1. Obstruction in overflow tube or drain line 	<ol style="list-style-type: none"> 1. Remove obstruction
Water leaks around door	<ol style="list-style-type: none"> 1. Doors not seating 2. Clogged spray pipe 	<ol style="list-style-type: none"> 1. Reseat doors 2. Clean spray pipe with brush
Weak or ineffective spray	<ol style="list-style-type: none"> 1. Clogged spray pipe 2. Manifolds not installed properly 3. Obstruction in pump 4. Pump rotation reversed 5. Suction strainer clogged 	<ol style="list-style-type: none"> 1. Clean spray pipe with brush pipe 2. Ensure proper placement of upper and lower pipes 3. Clear obstruction through pump inspection plate 4. Arrow on pump housing indicates direction, correct electrically 5. Clean suction strainer
Weak or ineffective final rinse spray	<ol style="list-style-type: none"> 1. Lime deposits in spray nozzles 2. Low water pressure 3. Clogged line strainer 4. Closed water supply valve 	<ol style="list-style-type: none"> 1. Clean or replace nozzles 2. Adjust to 20PSI 3. Remove line strainer and clean 4. Open ball valve
Water hammer	<ol style="list-style-type: none"> 1. Excessive water line pressure 	<ol style="list-style-type: none"> 1. Install water hammer valve
Machine vibrates or is noisy	<ol style="list-style-type: none"> 1. Pump rotation reversed 	<ol style="list-style-type: none"> 1. Arrow on pump housing indicates direction, correct electrically
Final rinse will not shut off	<ol style="list-style-type: none"> 1. Final rinse solenoid valve clogged 2. Diaphragm worn 3. Solenoid valve still powered-up 	<ol style="list-style-type: none"> 1. Disassemble valve and clean internal parts of scale or replace 2. Replace with solenoid valve repair kit 3. Check final rinse actuating circuit for proper operation

TROUBLESHOOTING

TECHNICAL ISSUES	POSSIBLE CAUSES	SOLUTIONS
Tank not filling/tank heat coming on with no water in tank	<ol style="list-style-type: none"> 1. Level float dirty 2. Level control system not working 	<ol style="list-style-type: none"> 1. Clean level float 2. Troubleshoot level control circuit
Tank temperature too low/high	<ol style="list-style-type: none"> 1. Thermostat not adjusted 2. Heat circuitry not working 3. Electric heat - power turned off 4. Electric heat - immersion heaters limed 5. Steam heat - steam turned off 6. Steam heat - not enough steam 7. Steam heat - condensate traps clogged 8. Gas heat - gas turned off 9. Gas heat - pilot not lit (if provided) 	<ol style="list-style-type: none"> 1. Adjust thermostat 2. Troubleshoot circuitry 3. Check circuit breakers 4. De-lime machine 5. Turn steam on 6. Adjust steam pressure per machine specs 7. Clean or replace condensate traps 8. Turn on gas 9. Re-light pilot

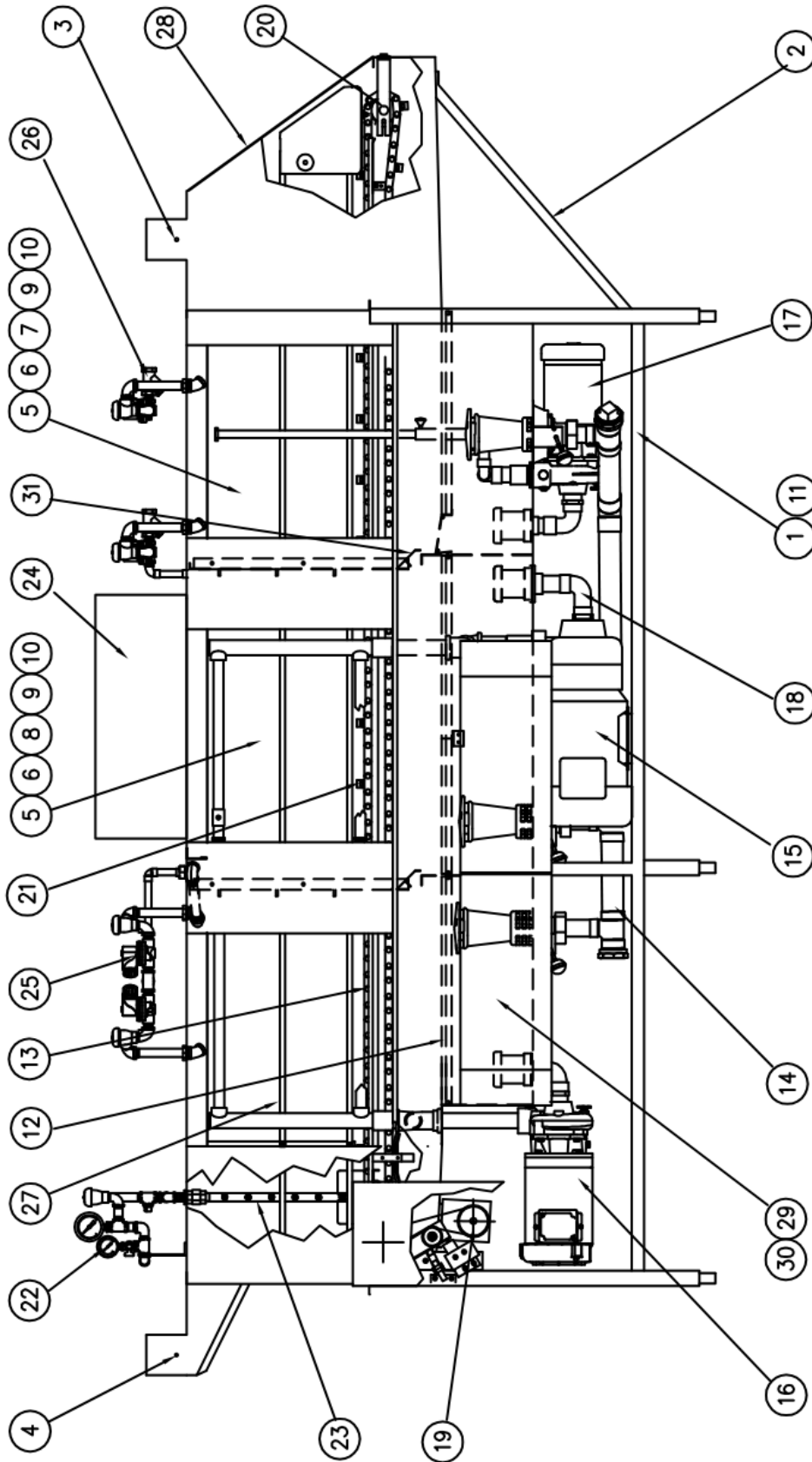

REV B - 12/02/02

1512-1 : TRAC 878 Assembly

ITEM	PART NO.	SIZE	DESCRIPTION	QTY
* 1	1512-5	B	Weldment, Shell, Leg & Frame (1-PC)	1
2	1448-4	B	Strut - Load Section	2
3	1512-37	B	Vent Damper - Load	1
* 4	1512-38	B	Vent Damper - Unload	1
* 5	1512-39	B	Door Channels	6
* 6	1472-25	A	Gasket - Door Channels	6
* 7	1512-40	B	Door - Prewash	1
* 8	1512-41	B	Door - Wash/Rinse	2
9	D2715A	A	Door Latch	6
10	977-47	A	Actuator - Door Interlock	3
11	1512-79	B	Weir Plate Placement	1
12	1512-44	B	Scrap Screen Locations	1
13	1512-48	B	Track Location	1
14	1512-53	B	Drain Assembly - RH Single Point	1
* 15	1512-55	B	Discharge Line Assembly, Wash	1
* 16	1512-60	B	Discharge Line Assembly, Rinse	1
* 17	1512-63	B	Discharge Line Assembly, RH Prewash	1
18	1512-43	A	Suction Line Assembly	1
19	1512-90	B	Drive Mechanism (without Dryer)	1
20	1512-68	B	Follower Shaft Assembly	1
21	1512-71	B	Chain Assembly (Tray Washer Only)	1
22	1512-74	B	Piping Assembly - Final Rinse (Ext.)	1
* 23	1512-104	B	Single Pipe Final Rinse Assembly	1
24	SK-4471	B	Control Panel Layout	1
25	1512-81	B	Tank Fill Assembly - Automatic	1
26	1512-107	B	Tempering Fill Assembly - Prewash	1
27	1512-82	B	Guide Rail & Baffle Instructions	1
* 28	1512-91	B	Frame - Entrance	1
29	1512-93	B	Back Plate - Heater Covers	1
30	1512-94	B	Cover - Heaters	1
31	1512-78	B	Water Shed	2

* Drawings Tabulated for Height Option

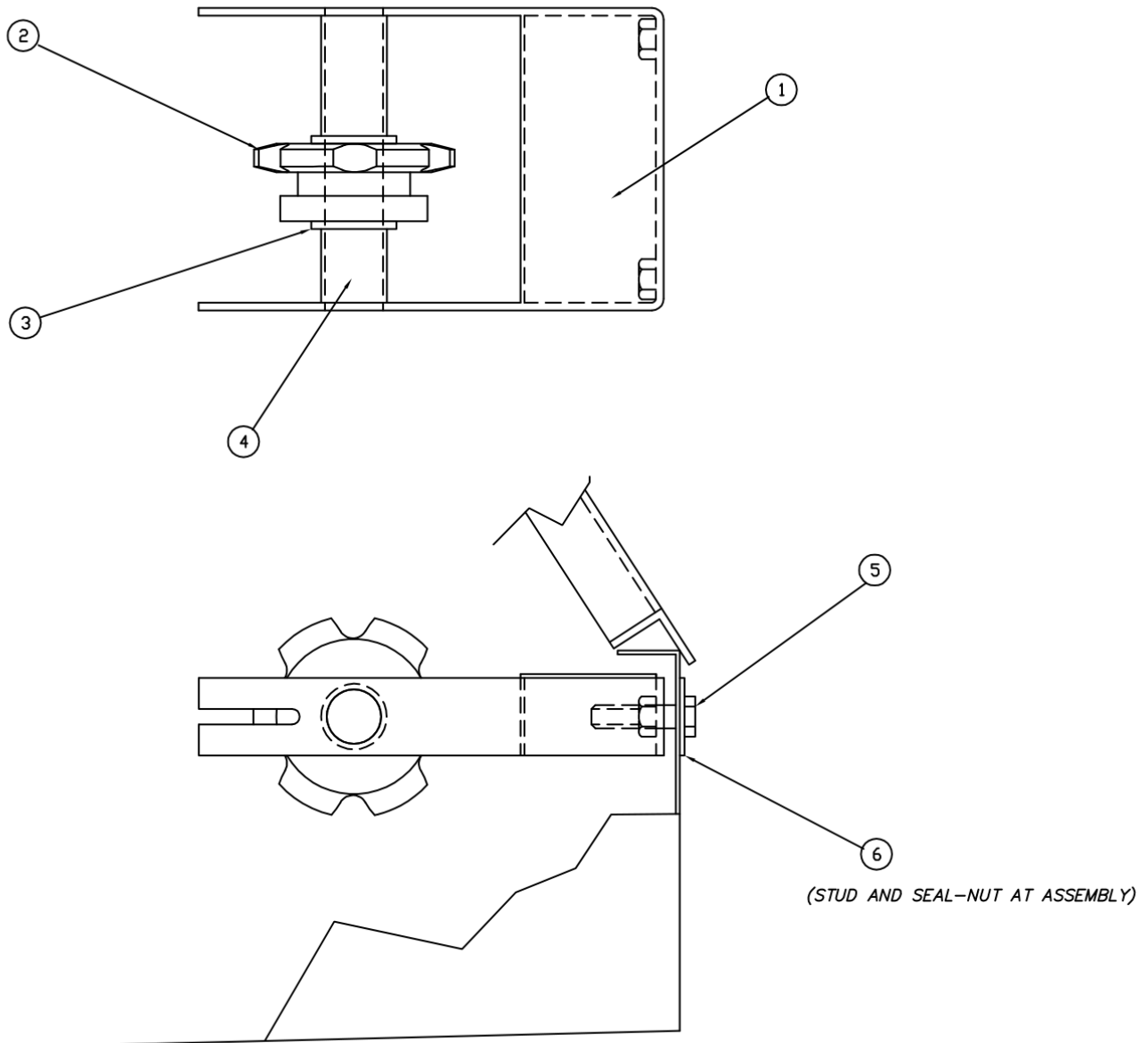
1512-68 : Follower Shaft Assembly

REV A - 06/28/01

ITEM	PART NO.	SIZE	DESCRIPTION	QTY
1	1512-70	B	Yoke Weldment	1
2	D2857	A	Sprocket - Follower	1
3	D2-525	A	Spacer	2
4	1512-69	A	Shaft - Follower	1
5	D309C-JC-16A	-	HHCS S/S 3/8-16 x 2"	2
6	1512-67	A	Adjustment Lock Bar	1

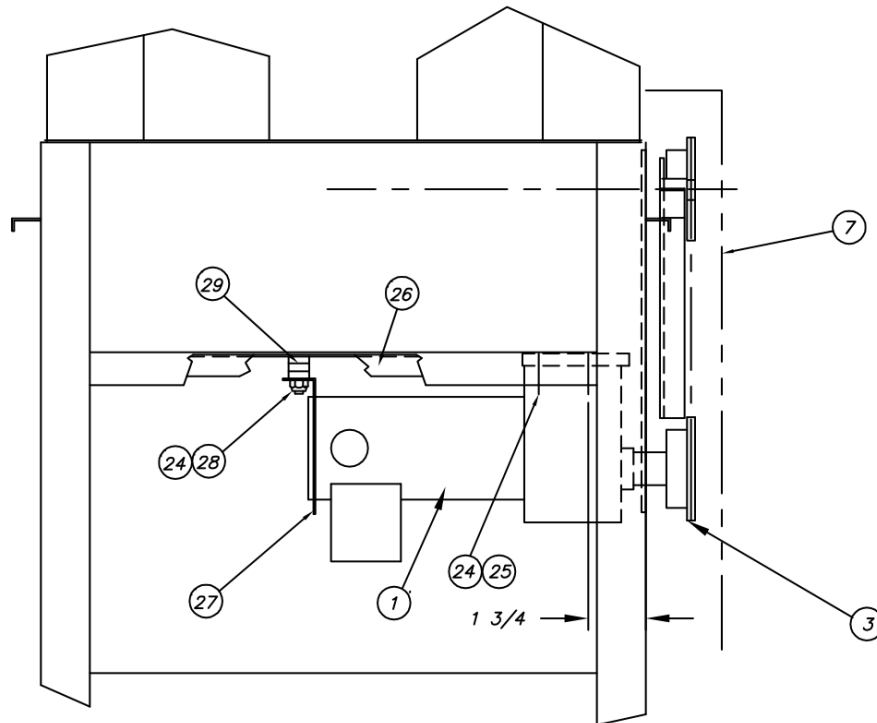
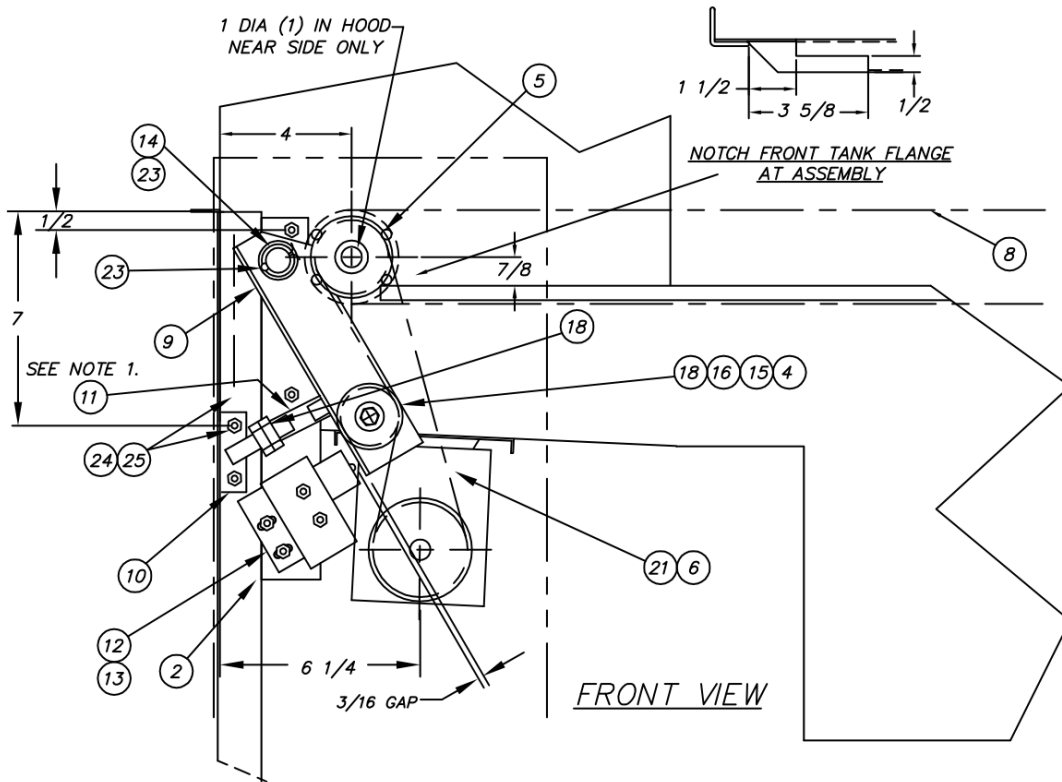
1512-90 : Drive & Chain Assembly (Dayton DC)

R.H. MACHINE SHOWN
L.H. MACHINE OPPOSITE

REV B - 05/02/06

1512-90 : Drive & Chain Assembly (Dayton DC)

ITEM	PART NO.	DESCRIPTION	QTY
1	-	Motor, Dayton 4Z130A	1
2	1512-97	Pivot Shaft Mounting Plate	1
3	D2779	Sprocket, 41B16	1
4	820-35	Sprocket Assembly, Idler	1
5	1512-98	Drive Shaft Assembly	1
6	D308C-41-CL	Chain, #41 x 53 Links	1
7	1512-66	Cover, Gear Motor	1
8	1512-71	Chain Assembly (Washer Only)	1
9	1361-136	Idler Arm	1
10	1397-4	Adjustable Spring Stop	1
11	D2834	Spring, Compression	1
12	D2215A	Microswitch	1
13	1512-100	Microswitch Bracket	1
14	D2771	Bushing, 1" OD x 3/4" Lg.	1
15	D309C-HC-3	Capscrew, 5/16-18 x 3/4" Lg.	1
16	D313C-H2	Lockwasher, 5/16"	1
17	D3-824	Washer, 5/16" ID x 1 1/8" OD	1
18	D312C-LC-1	Hex Nut 1/2-13	2
19	D309C-EF-4G	Weldstud #10-32 x 1/2"	4
20	D312C-EF-5	Locknut #10-32	4
21	D308B-41-CL	Connecting Link, #41 Chain	1
22	D311-1	Cotter Pin, 1/8" Diameter x 1 1/2" Lg.	1
23	D2-525	Washer, Nylon	1
24	D312C-GC-5	Locknut, 1/4-20	11
25	D309C-GC-4	Weldstud	10
26	1512-77	Reinforcement Channel	1
27	1512-101	Bootstrap Bracket	1
28	D309C-GC-9	Weldstud, 1/4-20 x 1 1/8" Lg.	1
29	957-7	Seal Washer	3

NOTES:

1. Spring to be compressed to 1 7/8" Lg.
2. This DWG. was #1361-148 Rev A. Use for Customers requiring variable speed DC Drive.

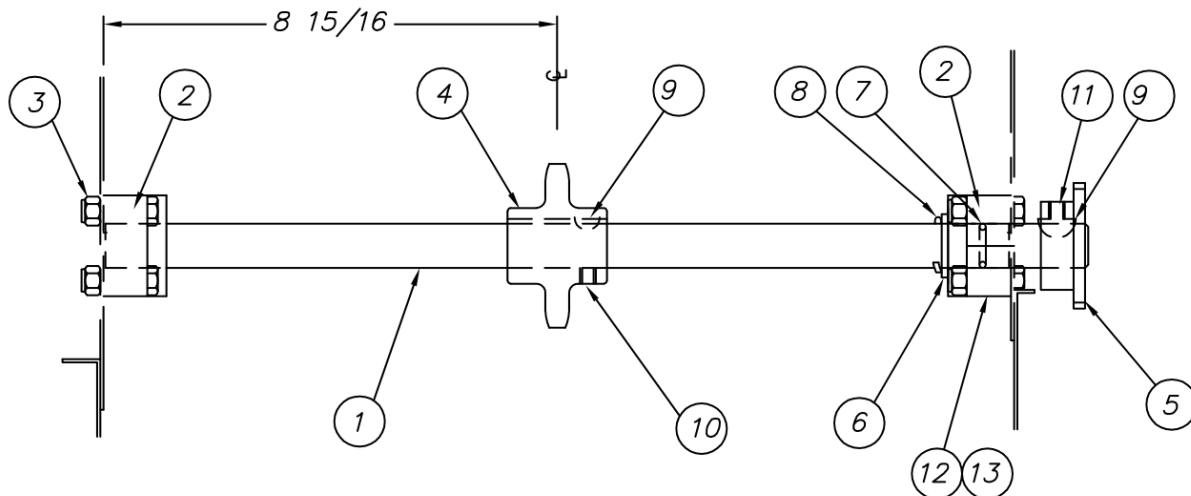
1512-98 : Drive Assembly

DRILL 11/32 DIA THRU
ITEM #2 LOWER HOLES
FRONT ONLY

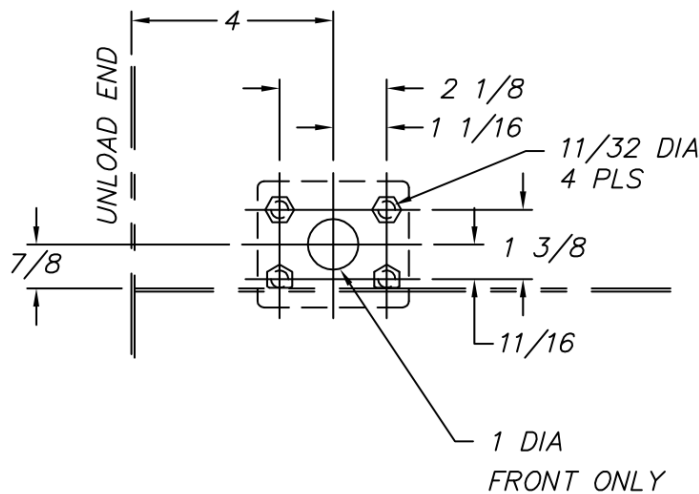

REV B - 03/12/08

ITEM	PART NO.	DESCRIPTION	QTY
1	1512-102	Drive Shaft	1
2	1162-110	Bearing - Plastic	2
3	D309C-HC-7A	Hex Head Screw 5/16-18 x 1 3/8"	6
4	975-55	Sprocket, Chain	1
5	982-56	Sprocket (41B14, 7/8" Bore)	1
6	D2-525	Washer, Nylon	1
7	D2-585	O-Ring, Buna-N 70 Duro	1
8	D311-1	Cotter Pin, 1/8" x 1 1/2" S/S	1
9	D302-4	Woodruff Key #11	2
10	D309C-HC-2.5H	Set Screw 5/16-18 x 3/8"	1
11	D309C-HC-5N	Set Screw 5/16-18 x 5/8"	1
12	1448-6	Milled Head Drive Brg Bolt	2
13	D312C-HC-5	5/16-18 UNC Stop Nut	8

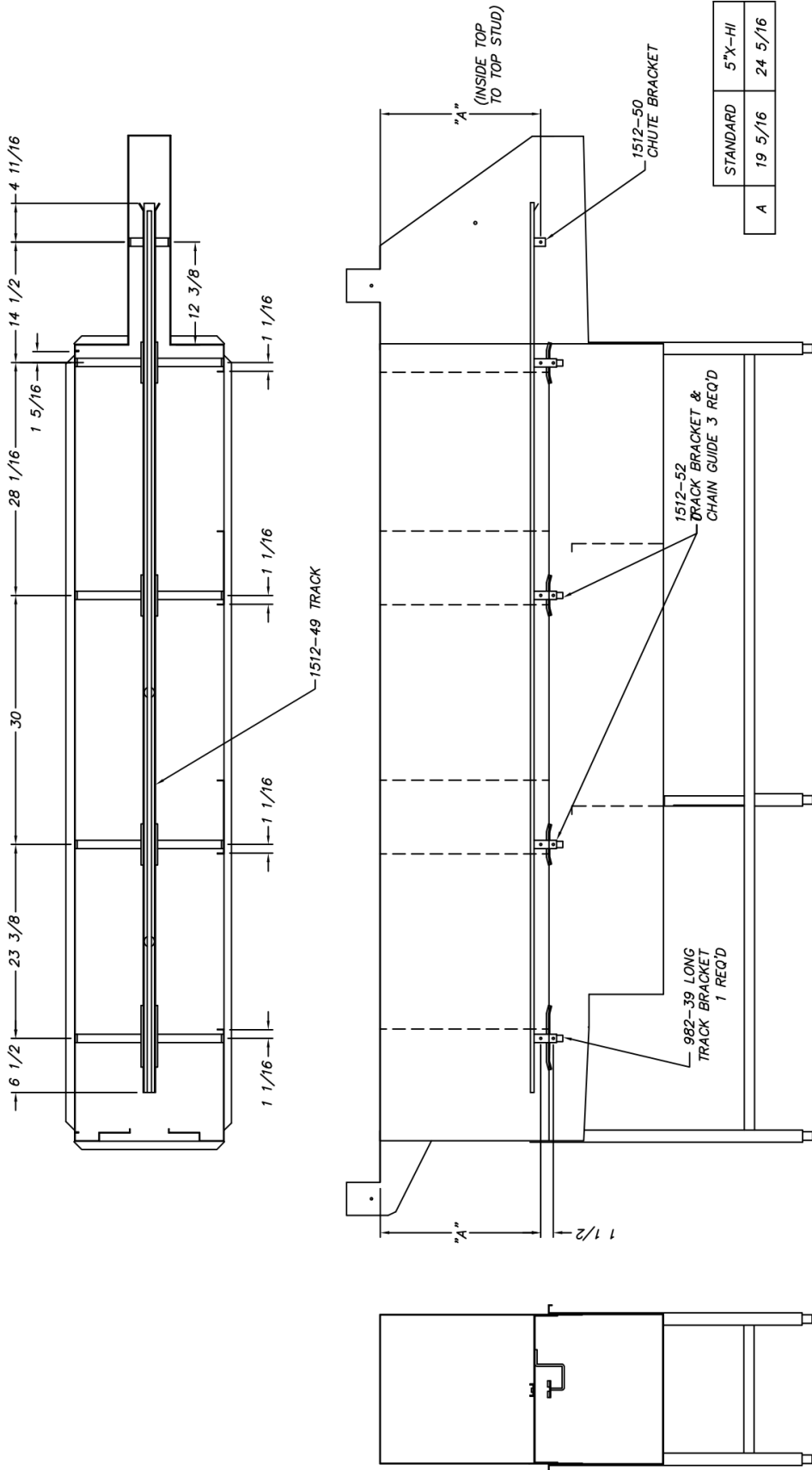
1512-48 : Track Location

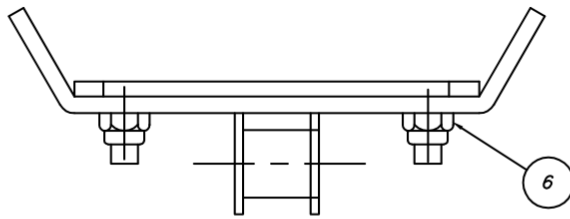
1512-72 : Chain Assembly with Integral Dryer

SECTION A-A

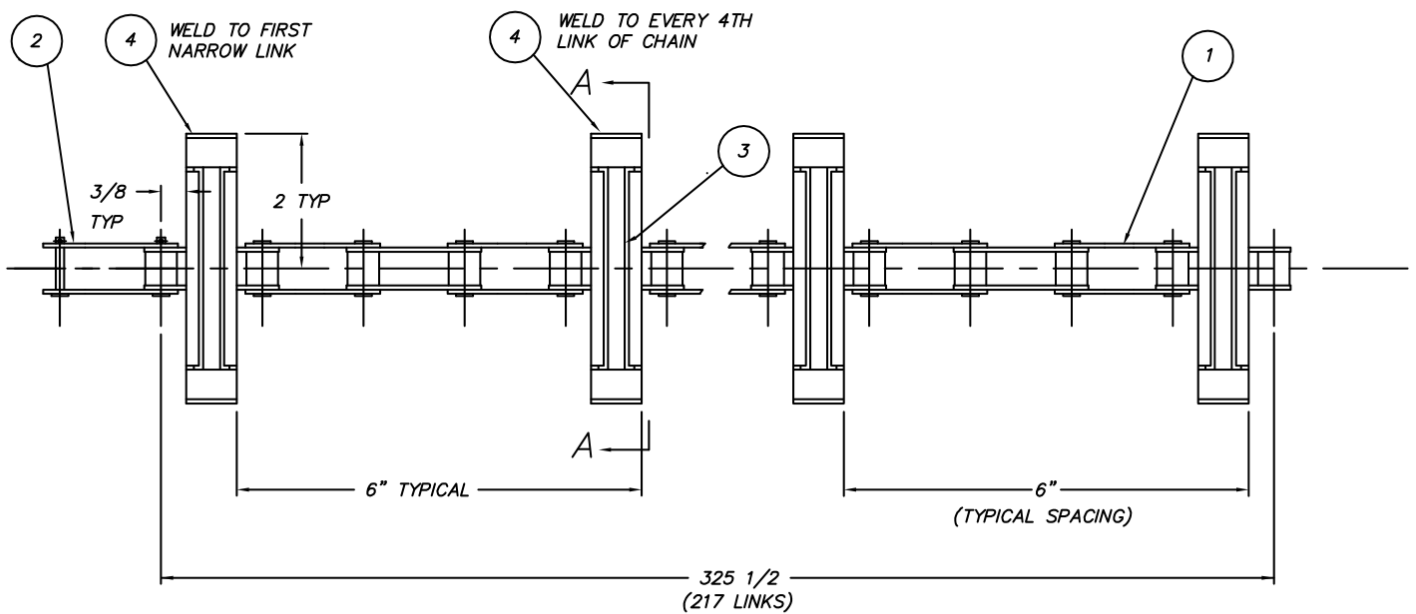

REV B - 10/21/09

ITEM	PART NO.	DESCRIPTION	QTY
1	D308C-1 1/2	Chain	1
2	D308C-1 1/2 CL	Connecting Link	1
3	1361-241	Crown & Retainer Assembly	55
4	1361-130	Cradle	55
5	-	-	-
6	D312C-EF-5	Locknut #10-32	110

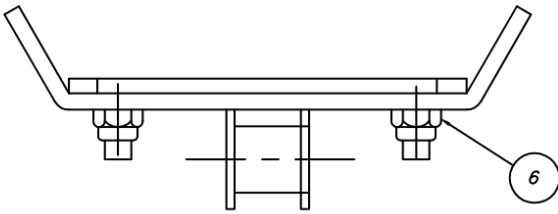
1512-72A : Chain Assembly with Double Dryer

SECTION A-A

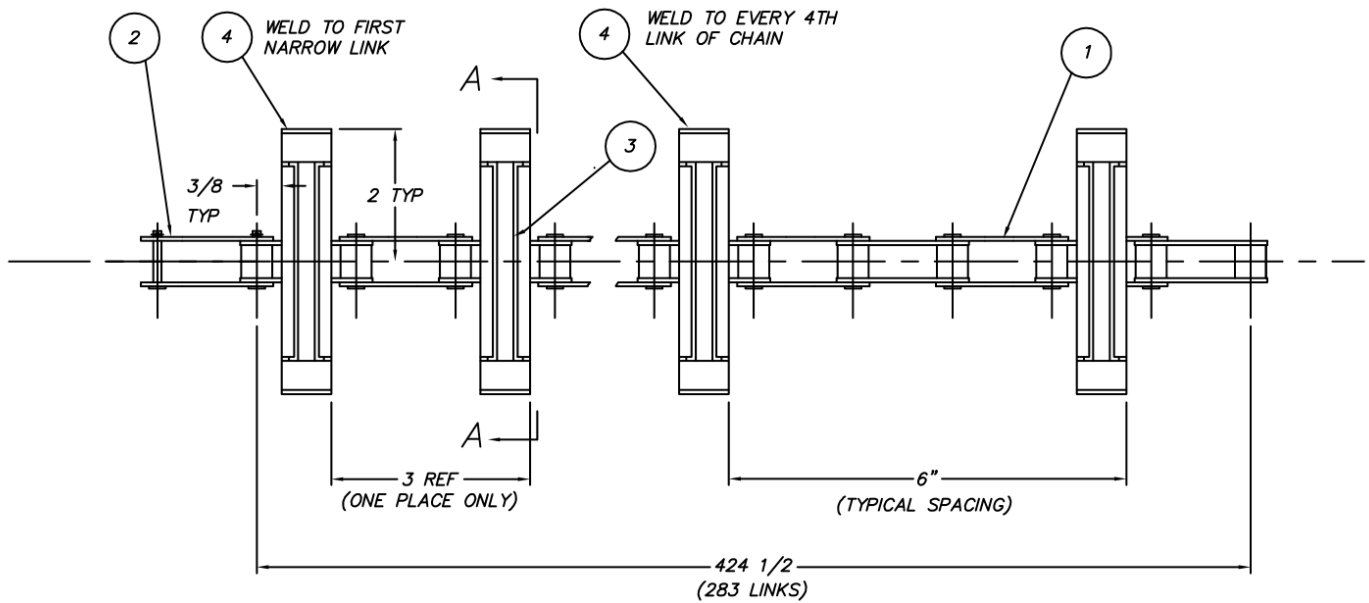

REV A - 04/21/16

ITEM	PART NO.	DESCRIPTION	QTY
1	D308C-1 1/2	Chain	1
2	D308C-1 1/2 CL	Connecting Link	1
3	1361-241	Crown & Retainer Assembly	72
4	1361-130	Cradle	72
5	-	-	-
6	D312C-EF-5	Locknut #10-32	142

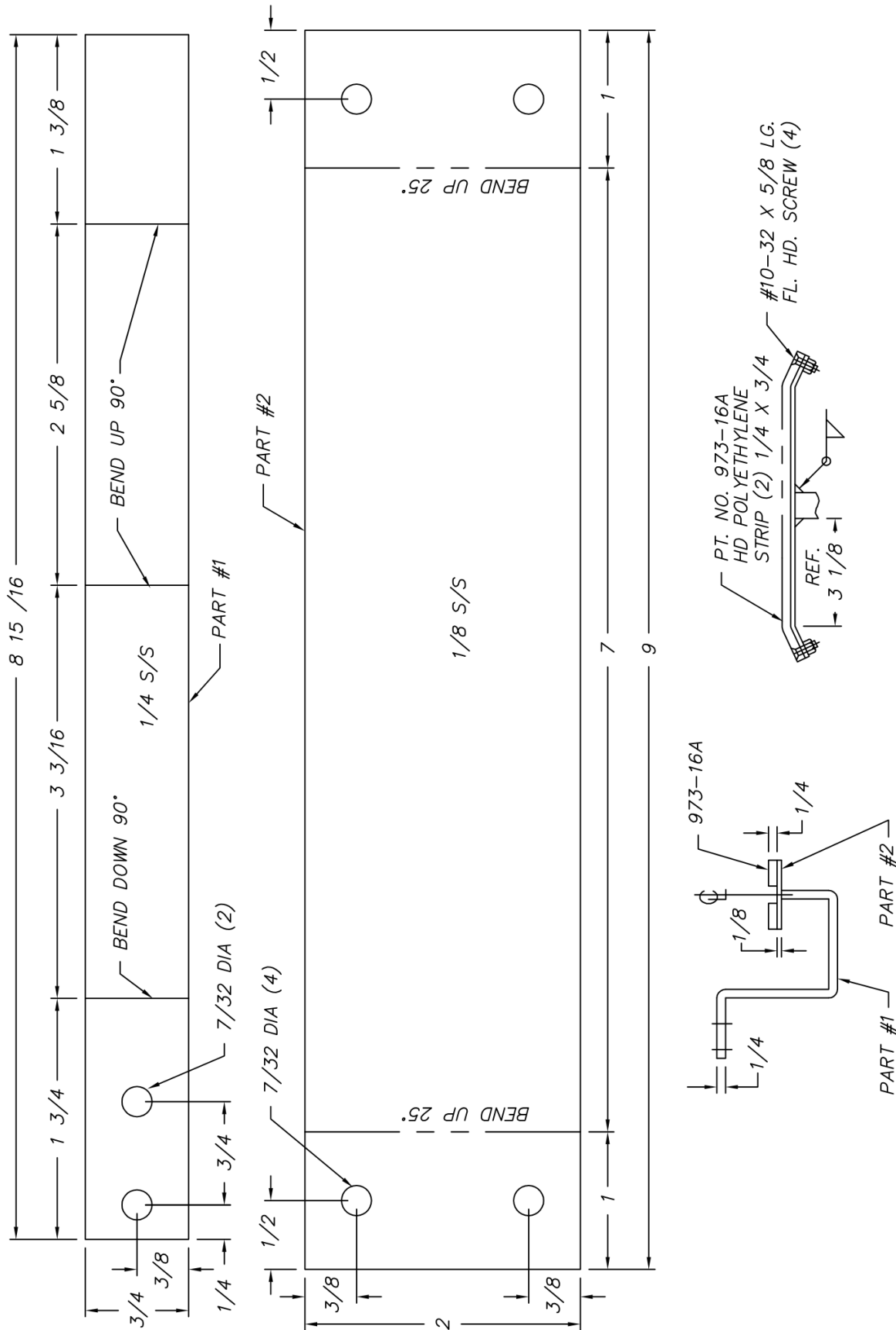

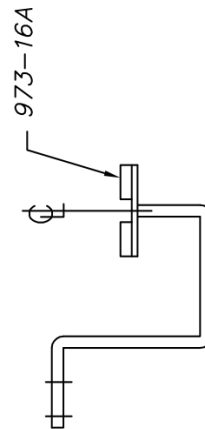
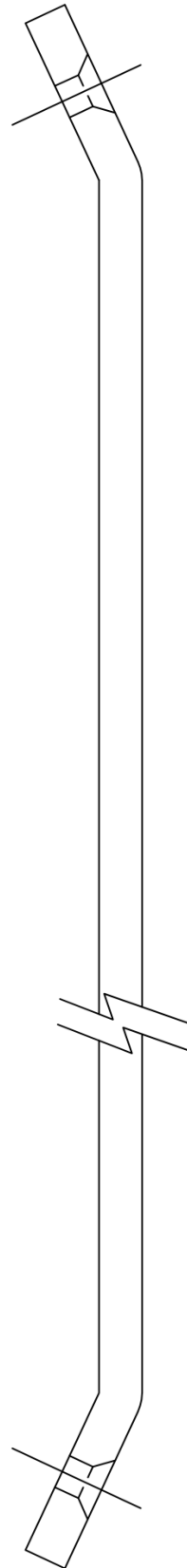
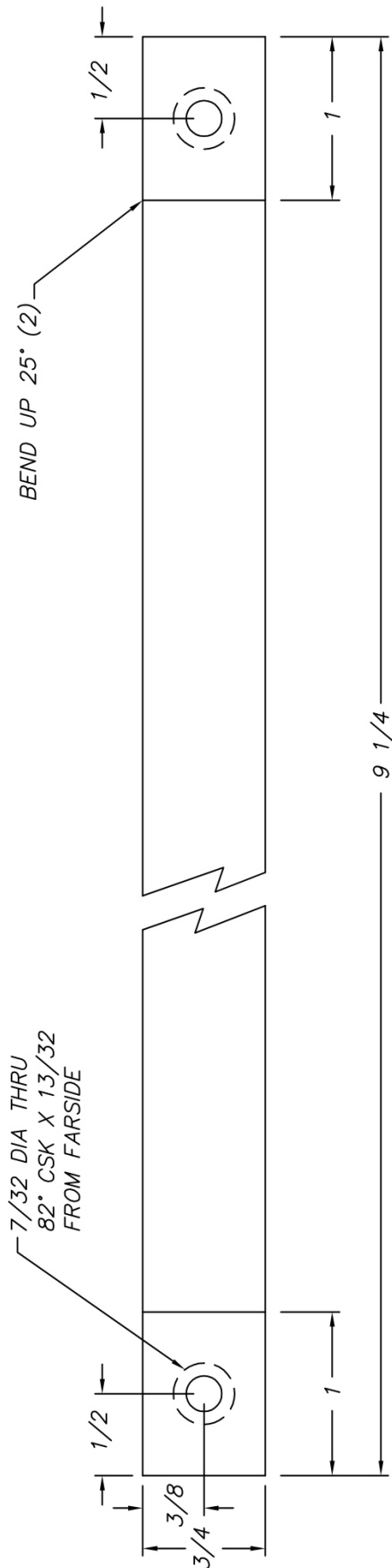
973-16A : Chain Guide (Poly Strip)

REV B - 06/24/96

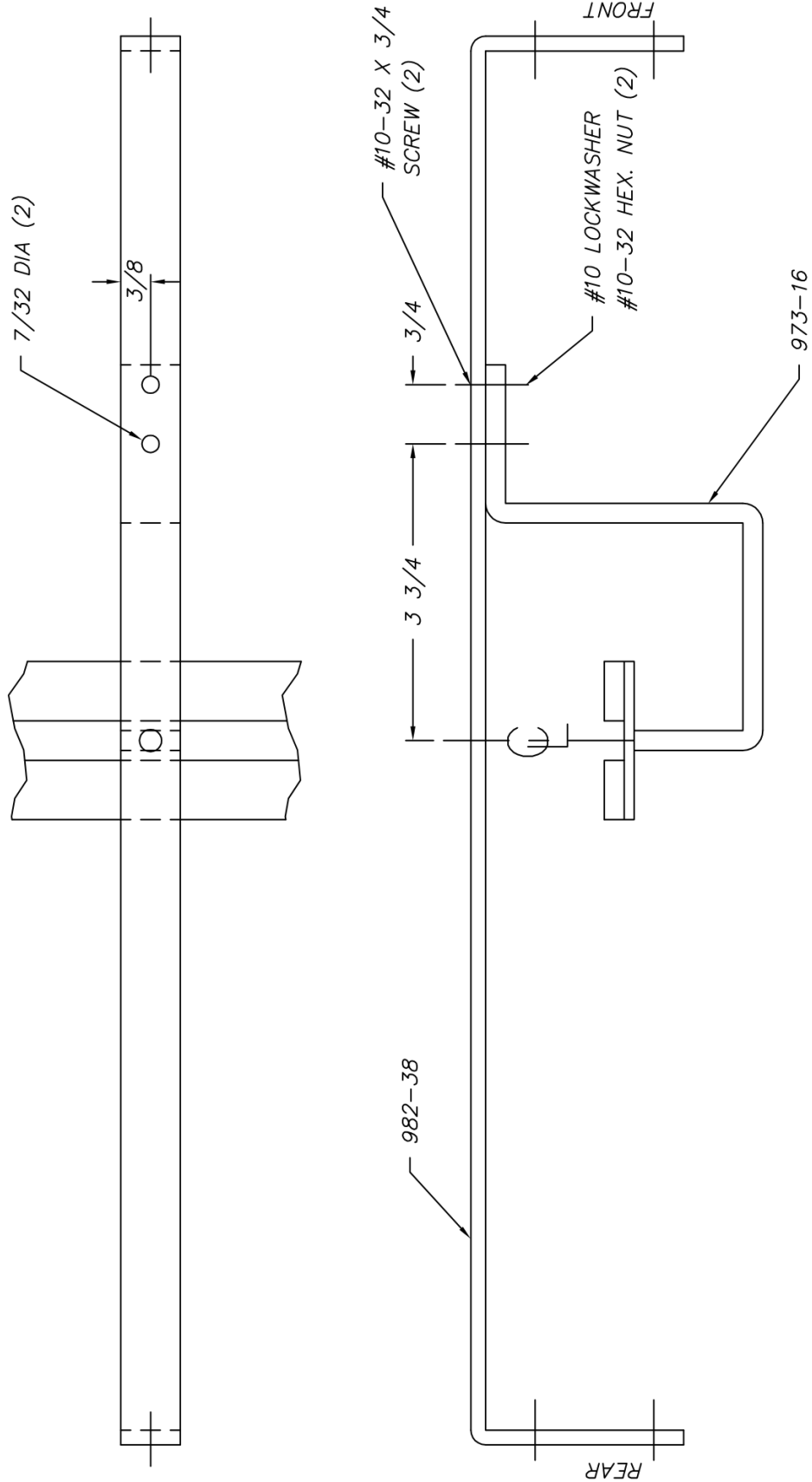
982-39 : Chain Guide & Track Bracket Assembly

REV A - 12/28/82

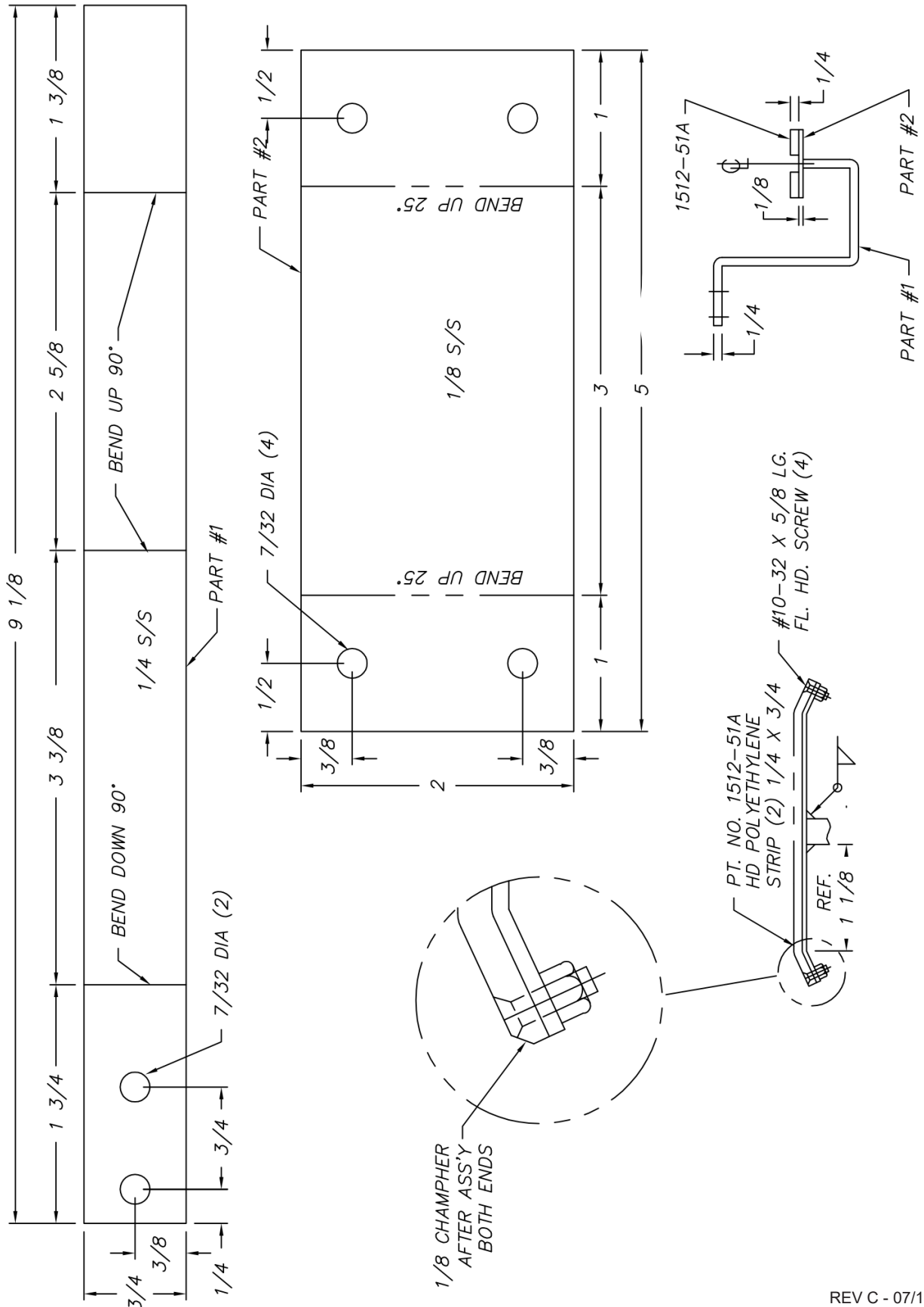

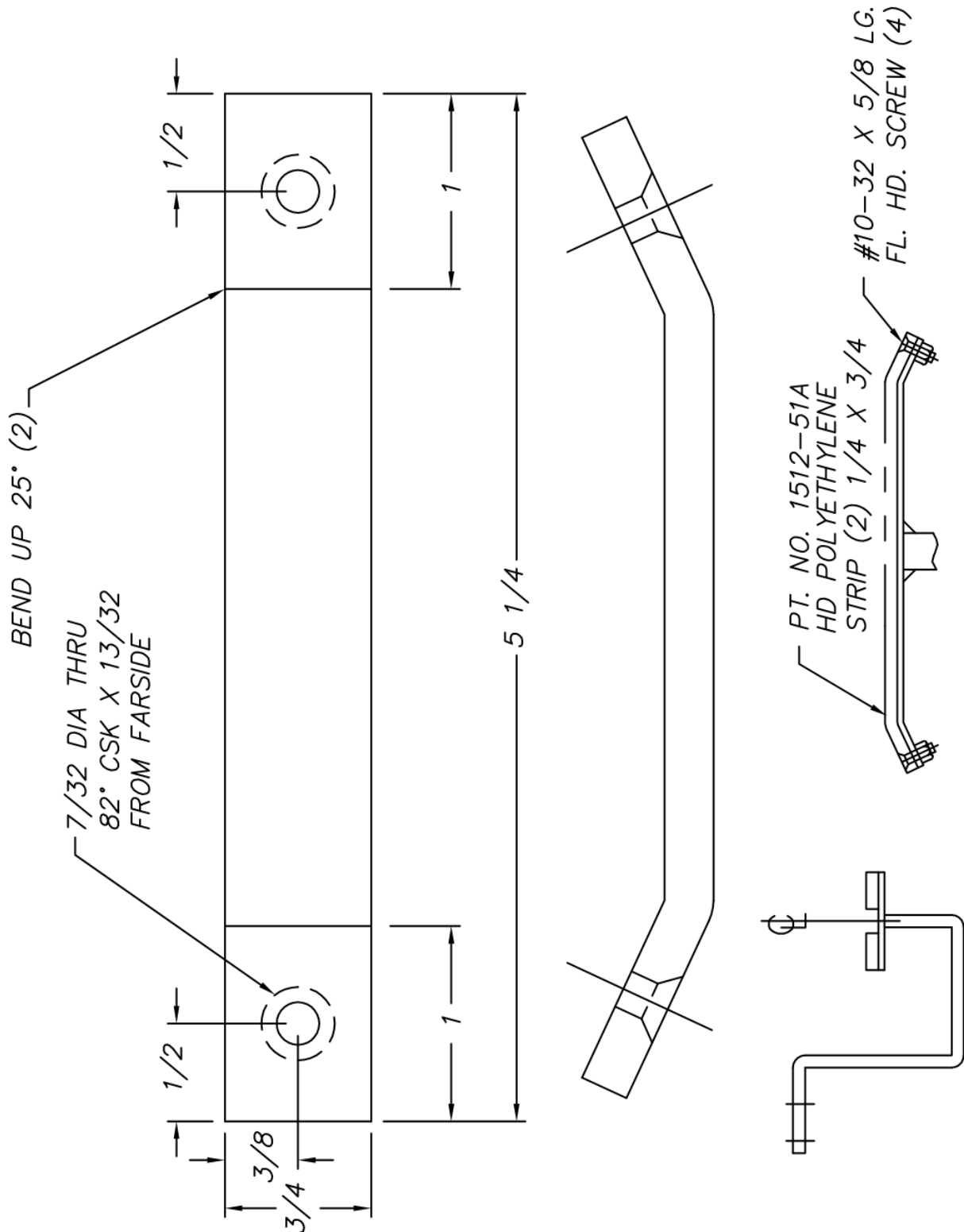
1512-51A : Chain Guide - Short (Poly Strip)

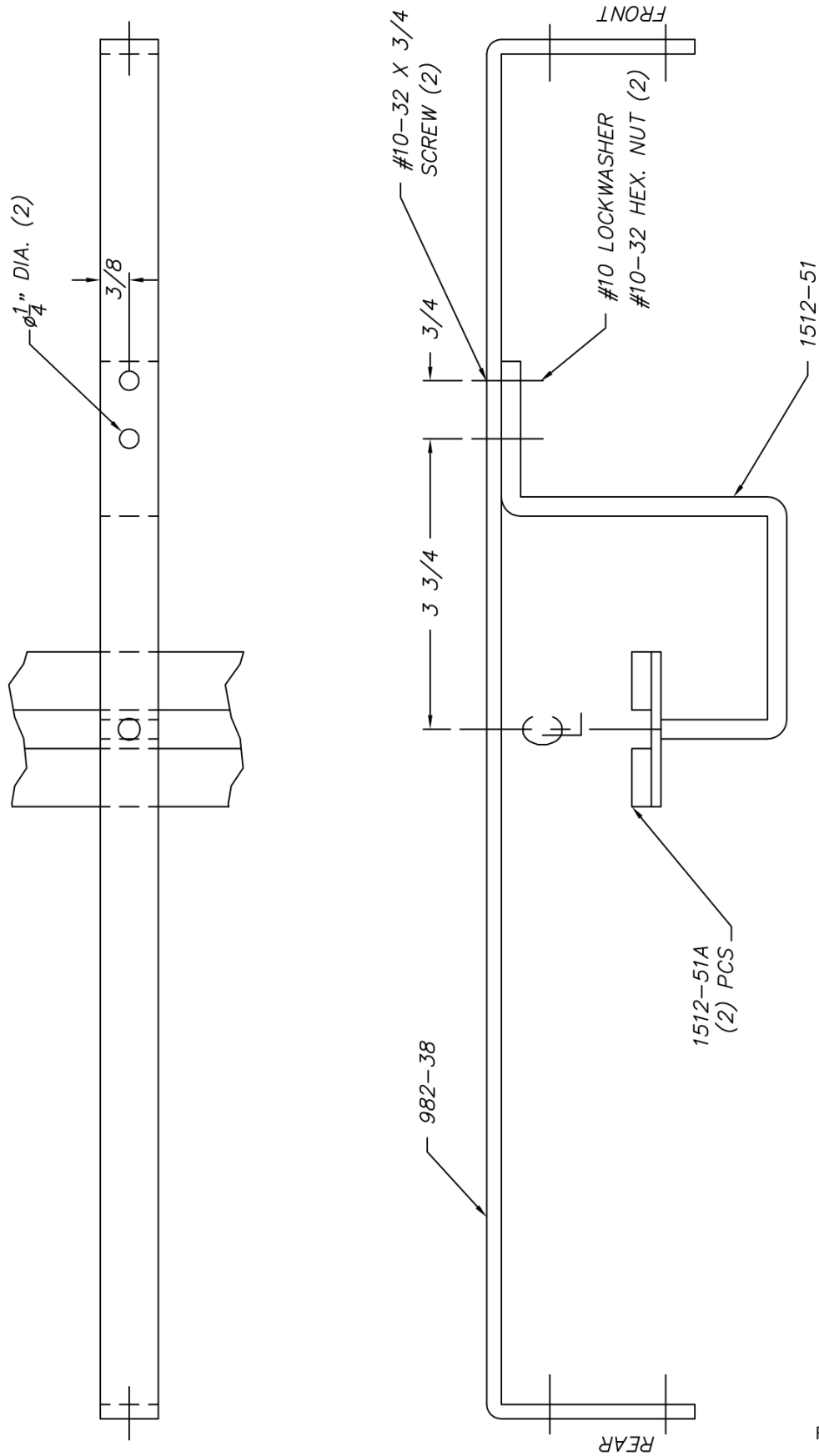
1512-52 : Chain Guide & Track Bracket Assembly

REV B - 07/17/14

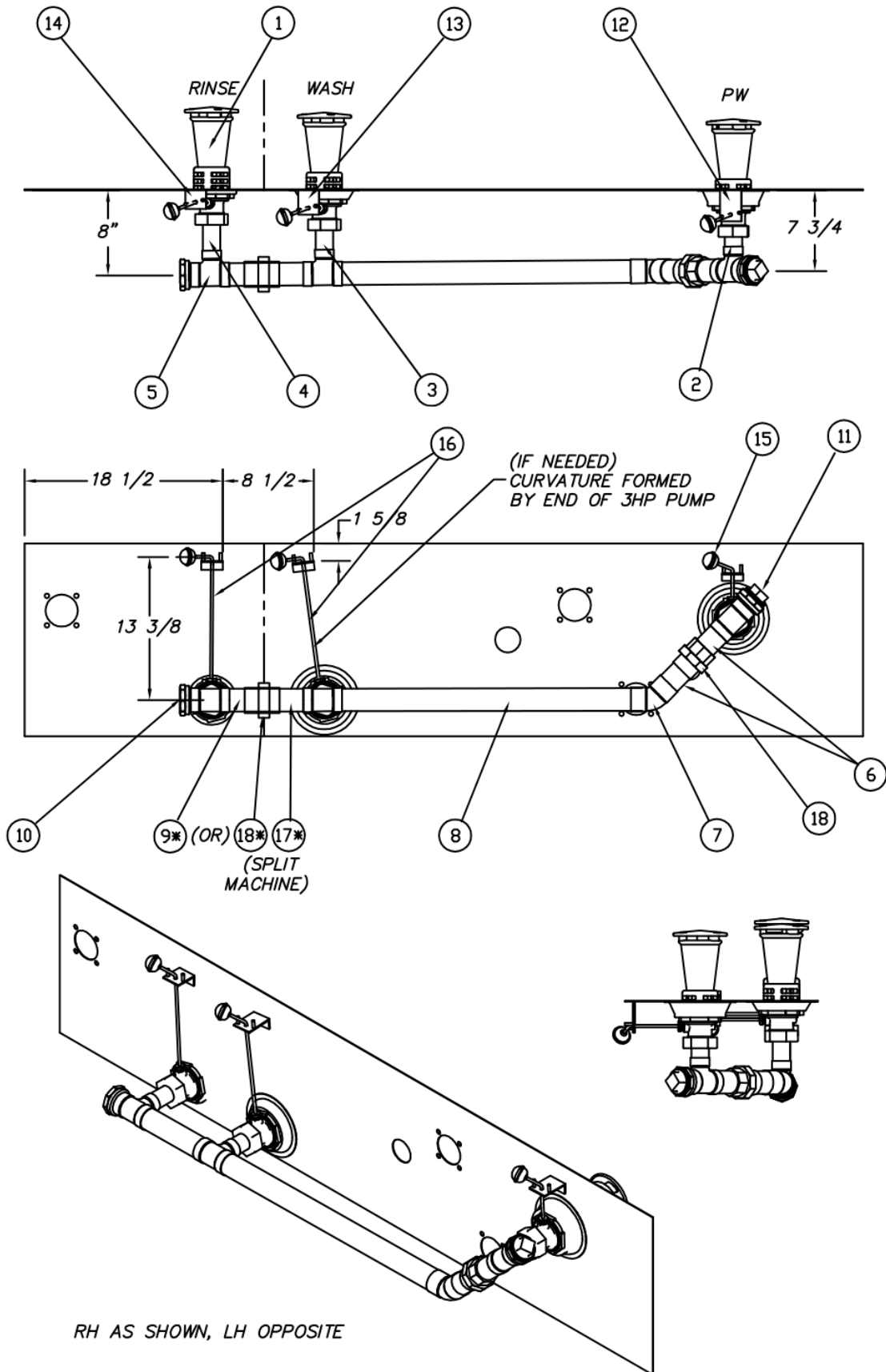
1512-53 : Drain Assembly

REV D - 09/22/09

ITEM	PART NO.	SIZE	DESCRIPTION	QTY
1	954-1	B	Drain Assembly	3
2	D207A-B12-12	-	Copper Tube 1 1/2" CTS x 3" Lg.	1
3	D207A-B12-15	-	Copper Tube 1 1/2" CTS x 3 3/4" Lg.	1
4	D207A-B12-18	-	Copper Tube 1 1/2" CTS x 4 1/2" Lg.	1
5	D320A-J3J3H3	-	Tee 2" C x 2" C x 1 1/2" C	3
6	D207A-B16-16	-	Copper Tube 2" CTS x 4" Lg.	2
7	D315A-J3-J3	-	45° Elbow 2" C x 2" C	1
8	D207A-B16-114	-	Copper Tube 2" CTS x 28 1/2" Lg.	1
* 9	D207A-B16-32	-	Copper Tube 2" CTS x 8" Lg.	1
10	D317A-J4-J1	-	Adapter 2" FTG x 2" FIPS	2
11	D328F-J2A	-	Pipe Plug 2" IPS	1
12	954-8A	A	Bracket - Drain Handle	1
13	954-8B	A	Bracket - Drain Handle	1
14	954-8	A	Bracket - Drain Handle	1
15	1100-79	B	Drain Handle Assembly	1
16	1512-59	B	Drain Handle Assembly	2
* 17	D207A-B16-14	-	Copper Tube 2" CTS x 3 1/2" Lg.	2
* 18	D318A-J3-J3	-	Union 2" CTS x 2" CTS	1 or 2

* Extra Union in Split Machine ONLY

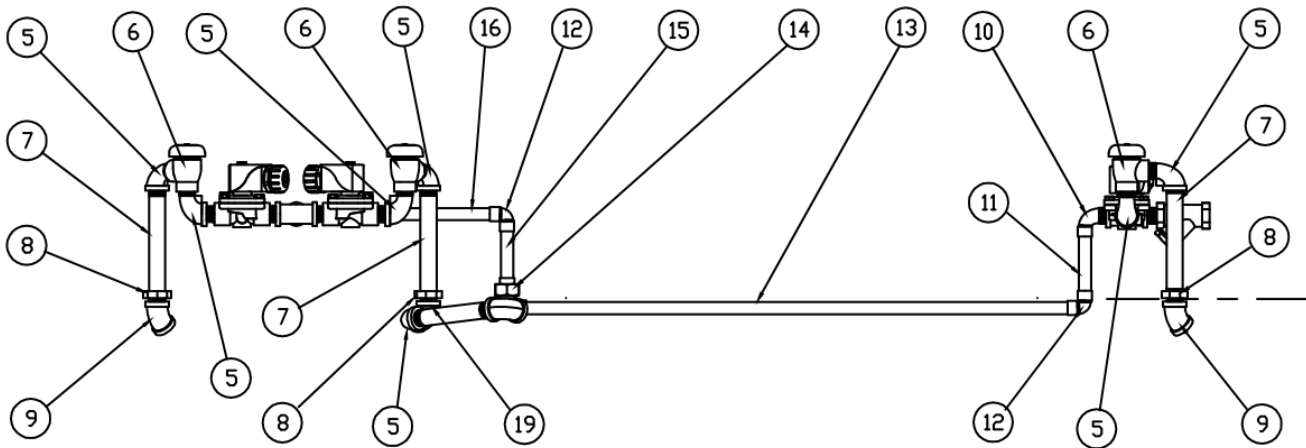
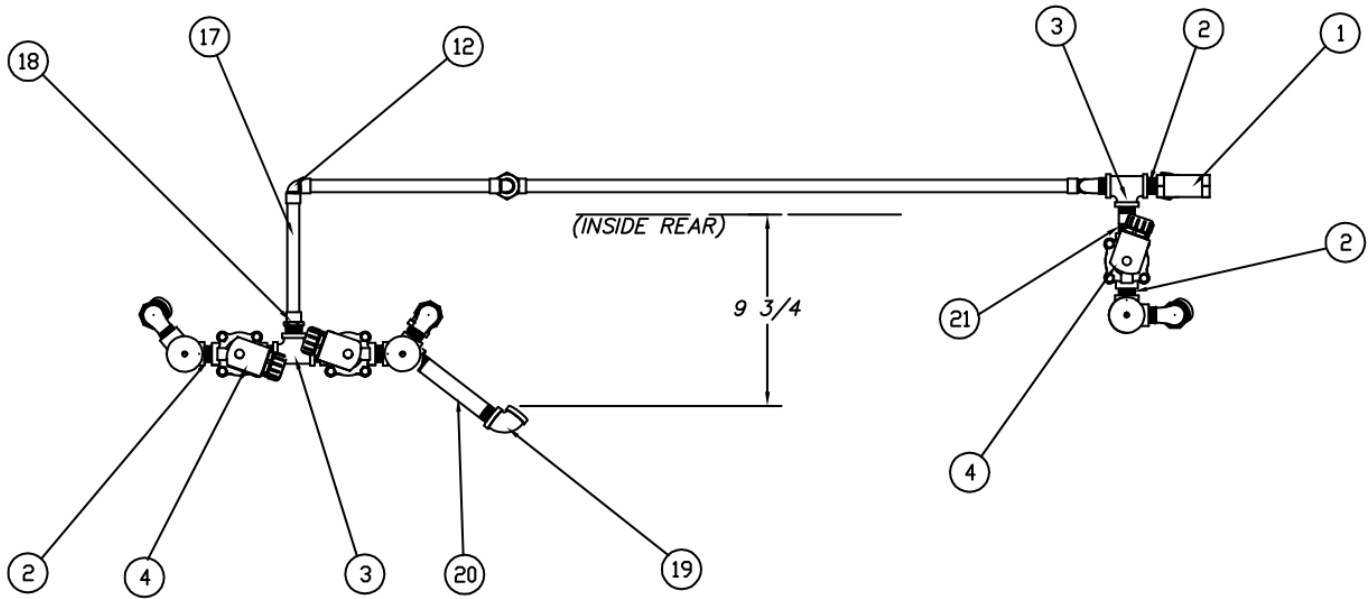
1512-81 : Tank Fill Assembly (Automatic Hot Water)

RH AS SHOWN, LH OPPOSITE

REV D - 12/03/02

1512-81 : Tank Fill Assembly (Automatic Hot Water)

ITEM	PART NO.	DESCRIPTION	QTY
1	D2483A	"Y" Strainer 1/2" IPS	1
2	D314F-DC-00	Close Nipple 1/2" IPS	6
3	D320F-D1D1D1	Tee 1/2" IPS	2
4	D2930	Solenoid 1/2" IPS	3
5	D316F-D1-D2	90° Street Elbow 1/2" IPS	7
6	D2241	Vacuum Breaker 1/2" IPS	3
7	D314F-DL-48	Nipple (Long One End) 1/2" IPS x 6" Lg.	3
8	D326F-D1	Locknut 1/2" IPS	3
9	D315F-D1-D1	45° Elbow 1/2" FIPS	2
10	D317A-D3-D2	90° Adapter Elbow 1/2" C x 1/2" MIPS	1
11	D207A-B4-15	Copper Tubing 1/2" C x 3 3/4" Lg.	1
12	D316A-D3-D3	90° Elbow 1/2" C x 1/2" C	3
13	D207A-B4-117	Copper Tubing 1/2" C x 29 1/4" Lg.	1
14	D319A-D3-D3	90° Union Elbow 1/2" C x 1/2" C	1
15	D207A-B4-12	Copper Tubing 1/2" C x 3" Lg.	1
16	D207A-B4-40	Copper Tubing 1/2" C x 10" Lg.	1
17	D207A-B4-26	Copper Tubing 1/2" C x 6 1/2" Lg.	1
18	D316A-D3-D2	Adaptor 1/2" C x 1/2" MIPS	1
19	D316F-D1-D1	90° Elbow 1/2" IPS	2
20	D314F-DS-44	Nipple 1/2" IPS x 5 1/2" Lg.	1
21	D314F-DS-16	Nipple 1/2" IPS x 2" Lg.	1

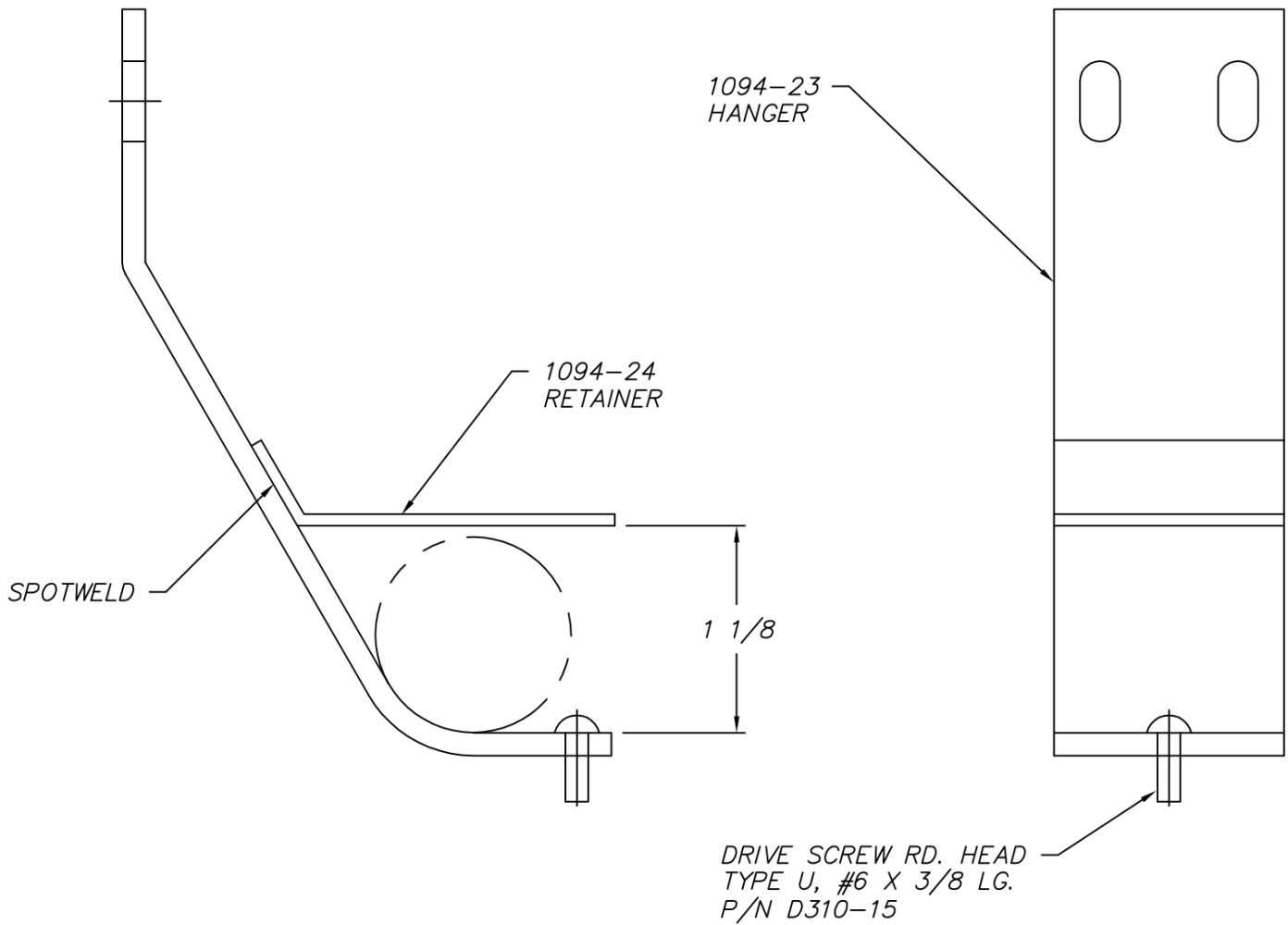

REV A - 09/28/92

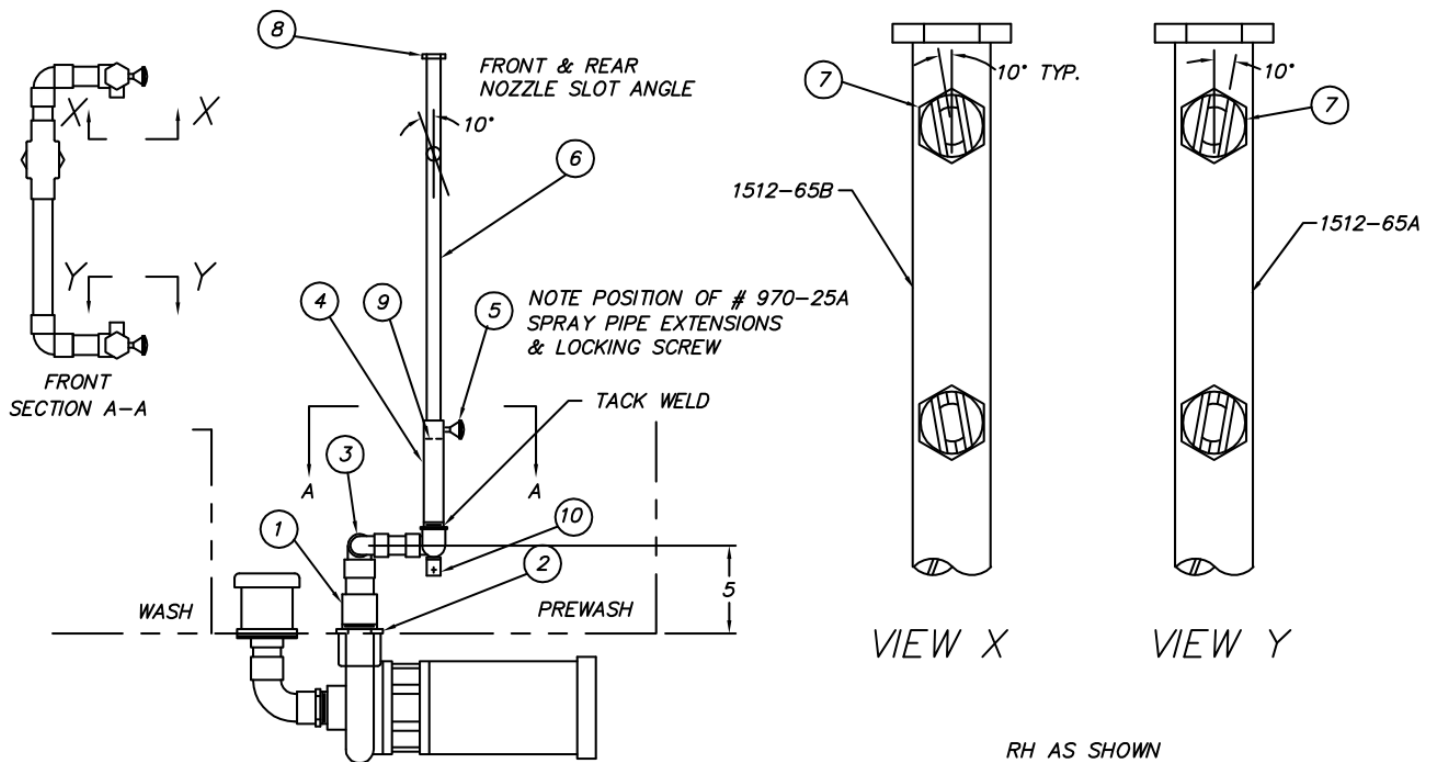
1512-63 : Prewash Discharge Line Assembly

RH AS SHOWN

REV B - 01/04/02

ITEM	PART NO.	SIZE	DESCRIPTION	QTY STD	QTY TRAY 19
1	963-11	A	Discharge Nipple	1	1
2	D326J-H1	-	Locknut 1 1/2" IPS	1	1
3	1072-14R	B	Discharge Manifold	1	1
4	970-25A	A	Spray Pipe Extension	2	2
5	562-87A	A	Locking Screw	2	2
6	1512-65	B	Spray Pipe 19 5/8" Long	2	-
			Spray Pipe 24 5/8" Long	-	2
7	D-2910	-	Spray Nozzle H 1/4 U-6570	10	12
8	D2-554-2	A	Plug 3/4-10 UNC-2A	2	2
9	D2-570	-	O-Ring (01-020)	2	2
10	970-53	A	Bracket - Discharge Line	2	2

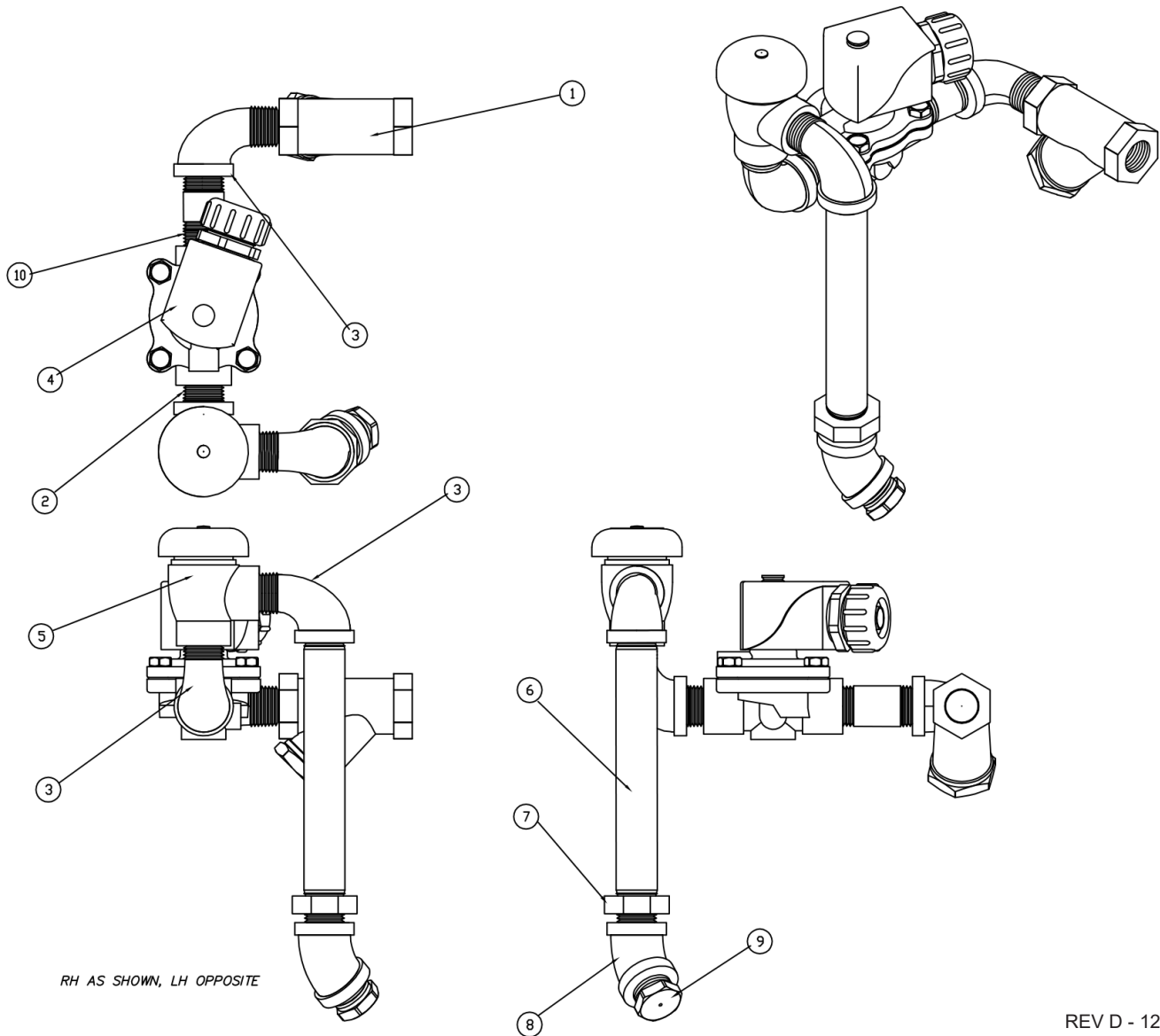
1512-107 : Prewash Tempering Cold Water Fill Assy

REV D - 12/03/02

ITEM	PART NO.	DESCRIPTION	QTY
1	D2483A	"Y" Strainer 1/2" IPS	1
2	D314F-DC-00	Close Nipple 1/2" IPS	1
3	D316F-D1-D1	90° Street Elbow 1/2" IPS	3
4	D2930	Solenoid Valve 1/2" IPS	1
5	D2241	Vacuum Breaker 1/2" IPS	1
6	D314F-DS-48	Nipple 1/2" IPS x 6" Lg. (Long One End)	1
7	D326F-D1	Locknut 1/2" IPS	1
8	D315F-D1-D1	45° Elbow 1/2" FIPS	1
9	D328F-D2A	Plug 1/2" MIPS (with 1/16" Hole)	1
10	D314F-DS-16	Nipple 1/2" IPS x 2" Lg.	1

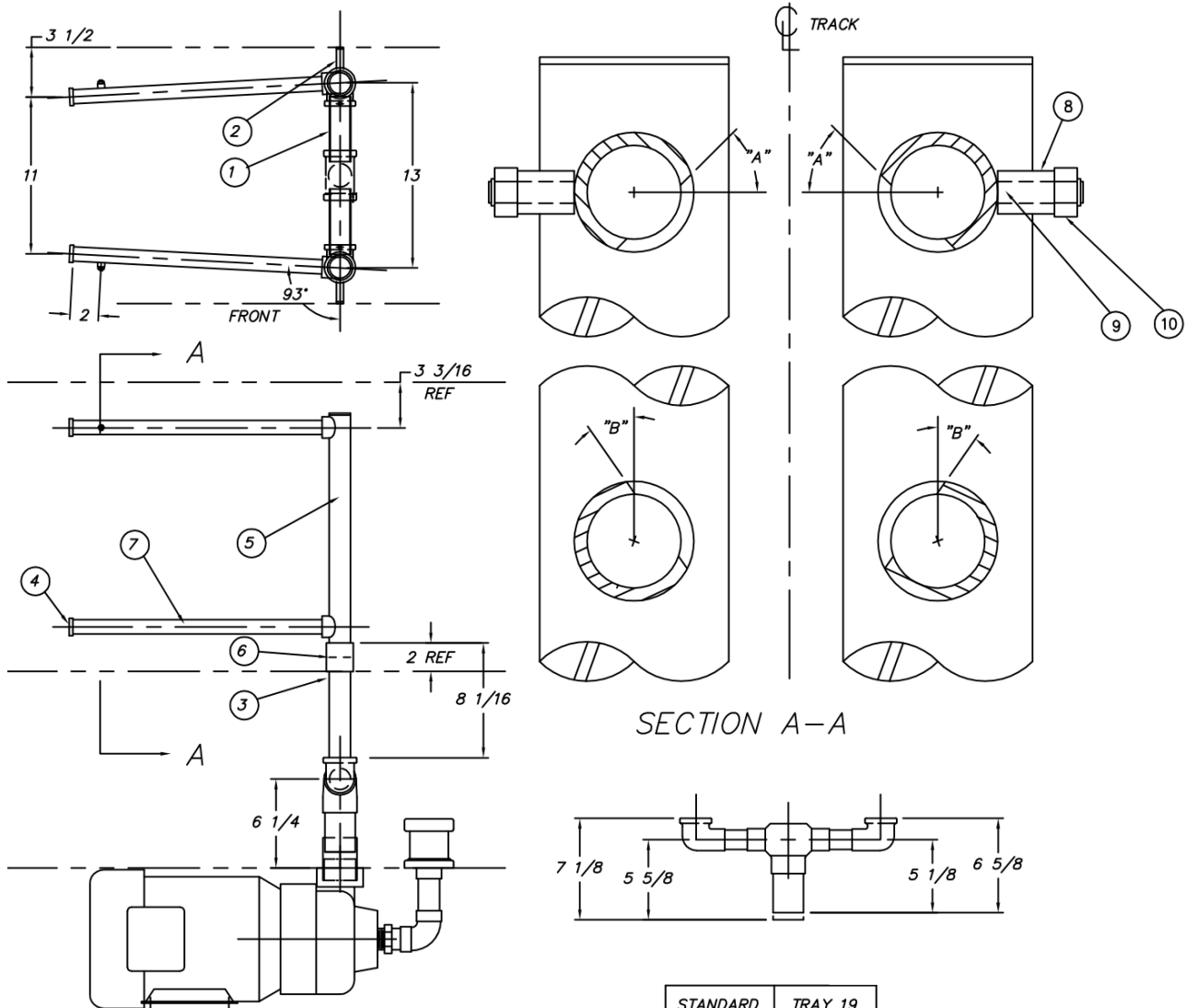
1512-55 : Wash Discharge Line Assembly

R.H. SHOWN L.H. OPPOSITE

REV C - 05/27/14

ITEM	PART NO.	SIZE	DESCRIPTION	QTY
1	1176-17	B	Discharge Manifold	1
2	1094-17	A	Bracket - Discharge Line	2
3	1512-56	A	Extension - Manifold	2
4	D2-554-2	A	Plug 3/4-10	4
5	1512-57	A	Spray Manifold	2
6	D-584	-	O-Ring (01-026)	2
7	1512-58	A	Spray Pipes	4
8	D3278	-	Nylon Standoff 1/4" ID x 1/2" Lg.	2
9	D309-EF-6G	-	Weld Stud 10-32 x 3/4"	2
10	D312C-EF-2	-	Nut 10-32	2

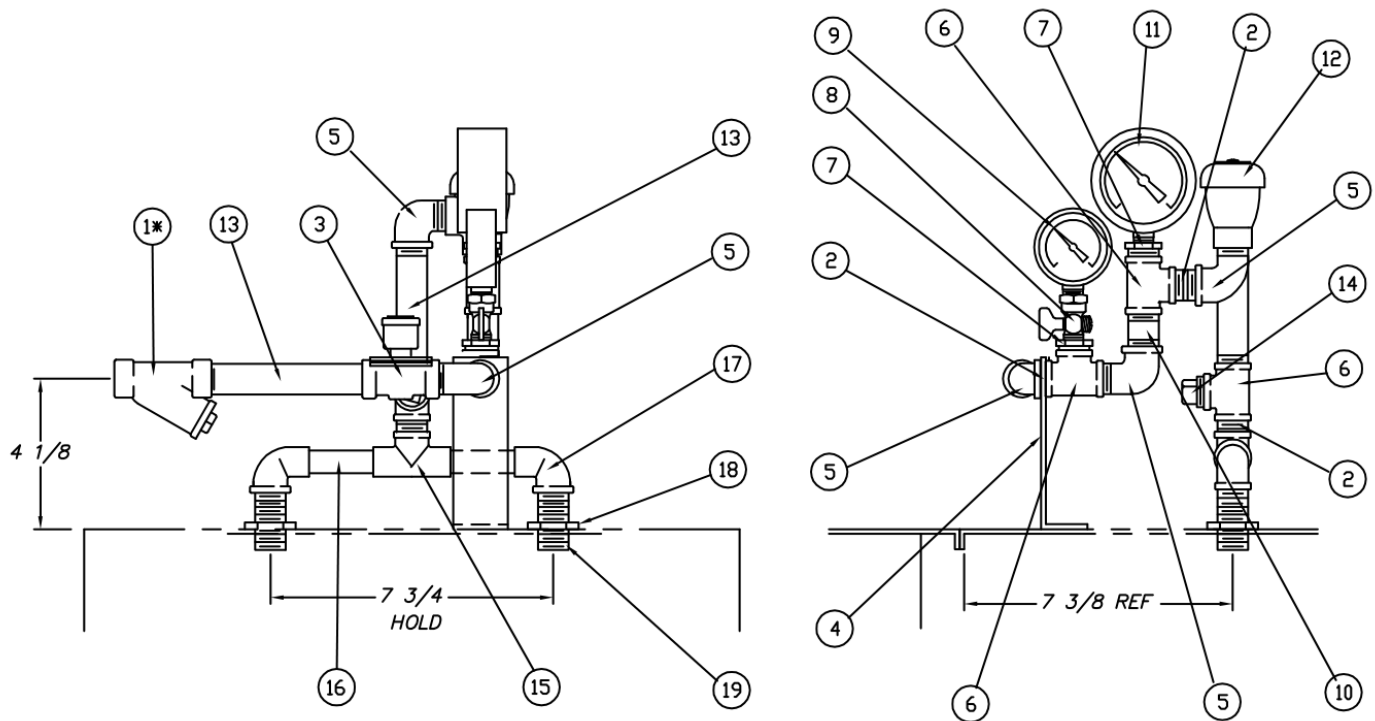
1512-74 : Final Rinse Piping Assembly

RH AS SHOWN, LH OPPOSITE

REV D - 10/02/02

ITEM	PART NO.	SIZE	DESCRIPTION	QTY
* 1	D2483A	-	"Y" Strainer 1/2" IPS	1
2	D314F-DC-00	-	Close Nipple 1/2" IPS	2
3	D2930	-	Solenoid Valve 1/2" IPS	1
4	951-79	A	Bracket	1
5	D316F-D1-D2	-	90° Street Elbow 1/2" IPS	3
6	D320F-D1D1D1	-	Tee 1/2" IPS	3
7	D322F-D2-B1	-	Hex Reducer 1/2" MIPS x 1/4" FIPS	2
8	D2497	-	Petcock 1/4" IPS	1
9	SK-1433	A	Pressure Gauge	1
10	D314F-DS-16	-	Nipple 1/2" IPS x 2" Lg.	1
11	D2495	-	Temperature Gauge 1/4" IPS	1
12	D2241	-	Vacuum Breaker 1/2" IPS	1
13	D314F-DS-32	-	Nipple 1/2" IPS x 4" Lg.	2
14	D328F-D2A	-	Pipe Plug 1/2" IPS	1
15	D320A-D3D3D1	-	Tee 1/2" C x 1/2" C x 1/2" IPS	1
16	D207A-K4-11	-	Copper Tube 1/2" x 2 3/4" Lg.	2
17	D316A-D3-D1	-	90° Elbow 1/2" C x 1/2" IPS	2
18	D314F-DA-16	-	Nipple 1/2" IPS x 2" All Thread	2
19	D326F-D1	-	Locknut 1/2" IPS	2

* Item #1 to be omitted from units with a booster

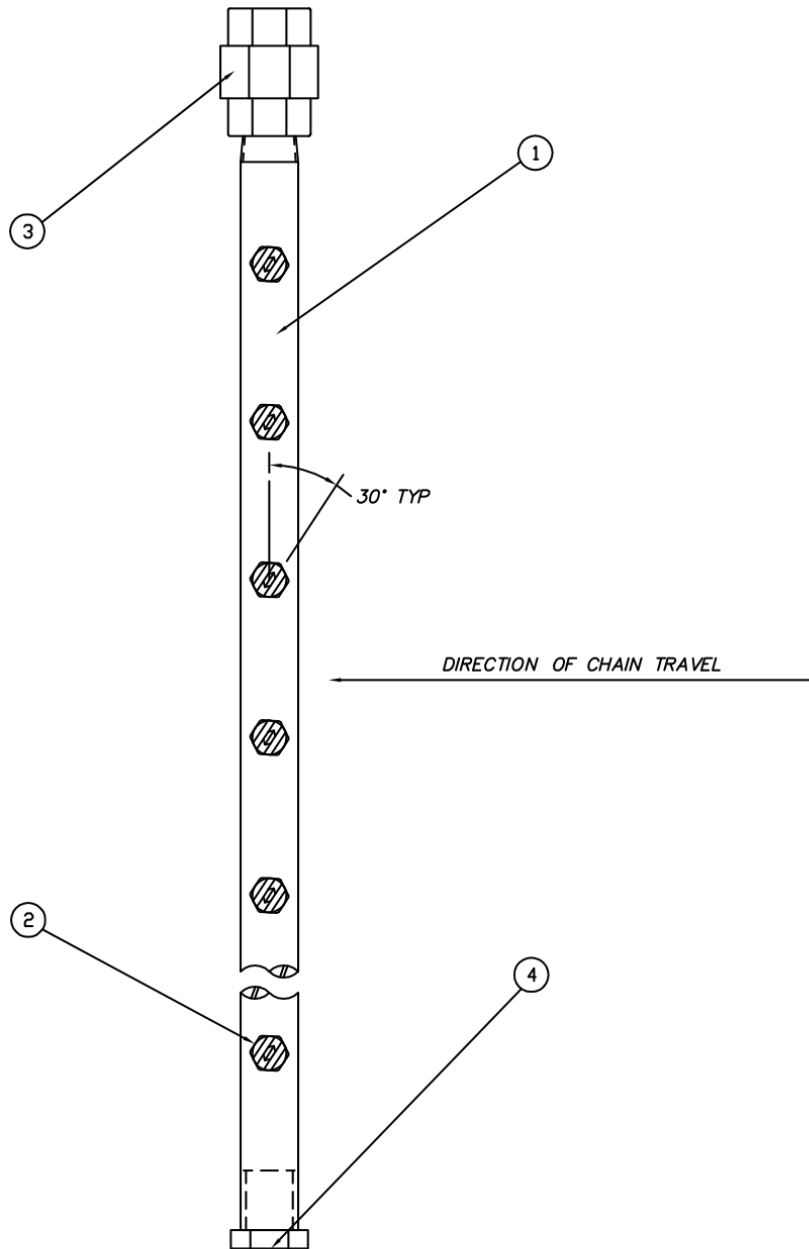
1512-104 : Final Rinse Internal Manifold Pipe

RH SHOWN, LH OPPOSITE, ONE OF EACH REQUIRED FOR EITHER HAND MACHINE.

REV A - 02/02/02

ITEM	PART NO.	SIZE	DESCRIPTION	QTY STD	QTY TRAY 19
1	1512-103	B	Spray Pipe - Final Rinse 16 3/4" Lg.	1	-
			Spray Pipe - Final Rinse 21 3/4" Lg.	-	1
2	D2911	-	Spray Nozzle 8004	6	8
3	D318J-D1-D1	-	Union 1/2" IPS Plated Brass	1	1
4	D2-554-2	A	Plug 3/4-10, Plastic	1	1

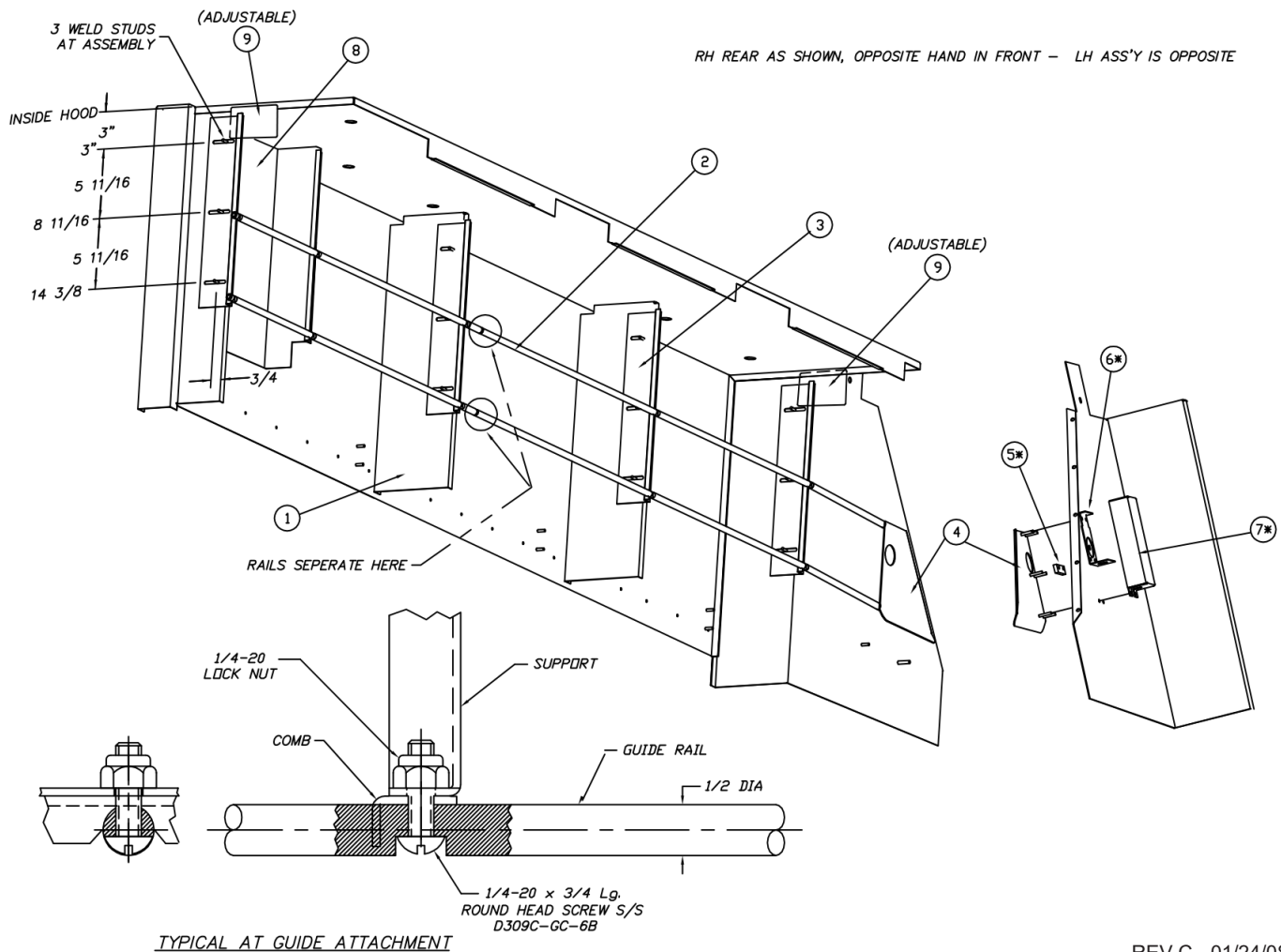
1512-82 : Guide Rail Installation

REV C - 01/24/08

ITEM	PART NO.	SIZE	DESCRIPTION	QTY
1	1512-85	B	Side Baffle	2 PR
2	1512-83	B	Guide Rail	4
**	3	B	Comb & Support - Guide Rail	5 PR
4	1512-87-1	B	Entrance Fender - Standard	1 PR
	1512-87-2	B	Entrance Fender - Pizza Dough	1 PR
	1512-87-3	B	Entrance Fender - Power Scrapper	1 PR
	1512-87-4	B	Entrance Fender - Thin Trays	1 PR
*	5	A	Spacer - Entrance Fender	2
*	6	B	Bracket - Photoelectric Eye	2
*	7	B	Bracket - Photoelectric Eye	2
8	1512-86	B	Final Rinse Baffle	2
9	-	-	Choke Plate, 22GA 2 3/4" x 6 1/2"	2

* Omit items 5, 6 & 7 unless photoelectric eye is ordered

** Omit combs on thin trays

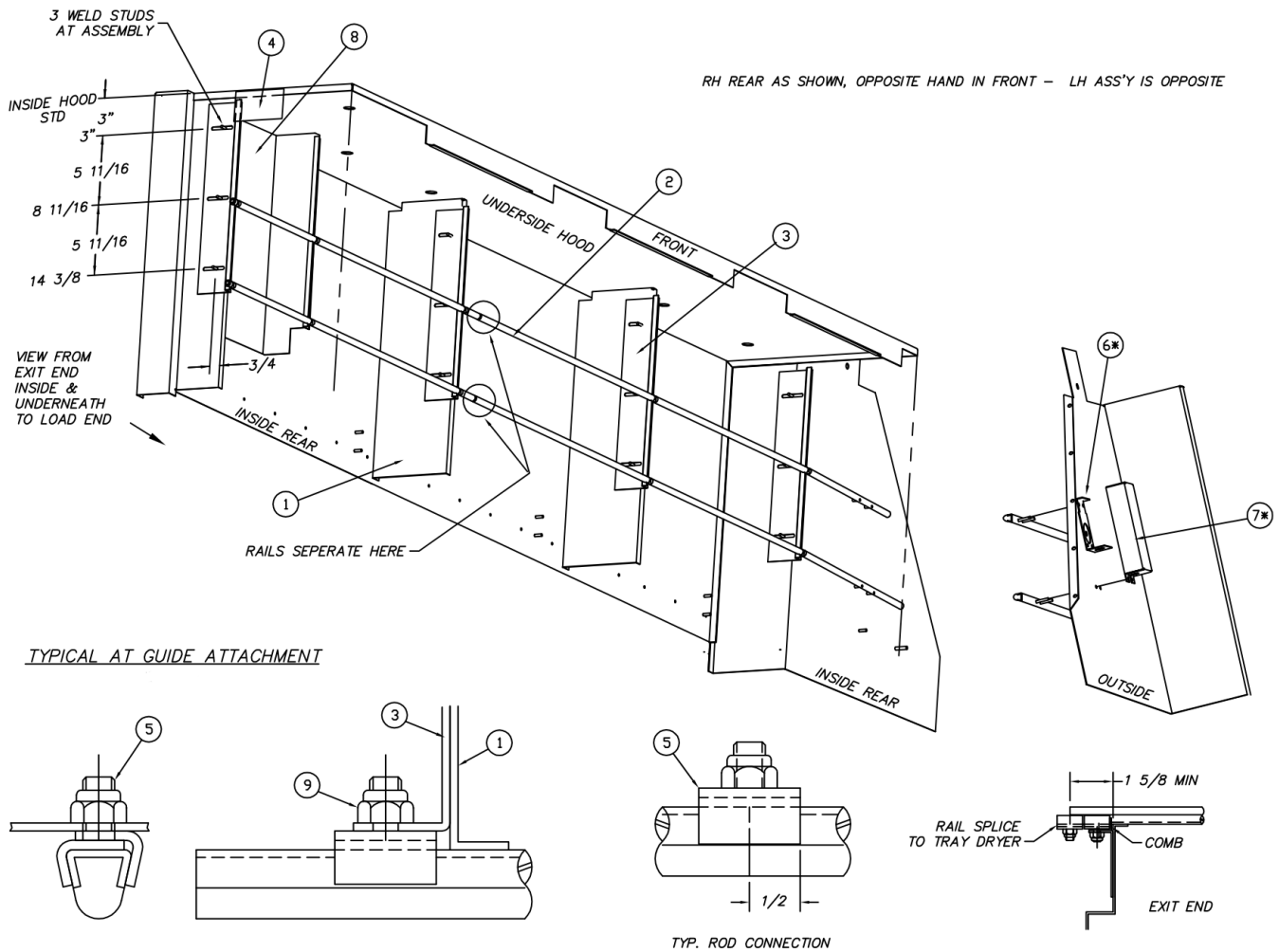
1512-142 : Guide Rail Installation (Pobco)

REV A - 04/21/15

ITEM	PART NO.	SIZE	DESCRIPTION	QTY
1	1512-85	B	Side Baffle (rev D or later)	2 PR
2	1512-141	B	Guide Rail Set (Standard Height)	4
	1512-143	B	Guide Rail Set (Extra High)	4
** 3	1512-140	B	Comb & Support - Guide Rail (Standard)	5 PR
	1512-144	B	Comb & Support - Guide Rail (Extra High)	5 PR
4	1512-145	A	Exit Heat Baffle	A/R
5	D3280	-	Pobco 2-pc Clamp x 5/8" Stud	28
* 6	1512-89	B	Bracket - Photoelectric Eye	2
* 7	1512-89	B	Cover - Photoelectric Eye	2
8	1512-86	B	Final Rinse Baffle	2
9	D312C-HC-5	-	5/16-18 Sealnut	28

* Omit items 6 & 7 unless photoelectric eye is ordered

** Omit combs on thin trays

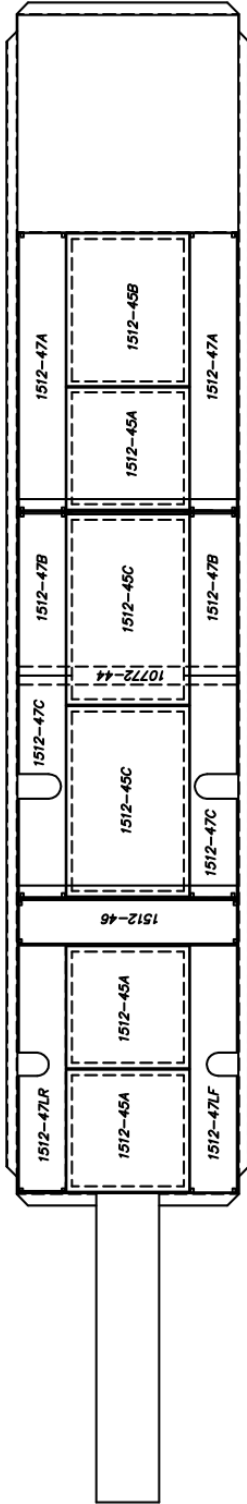
1512-44 : Scrap Screen Locations

LH PLAN

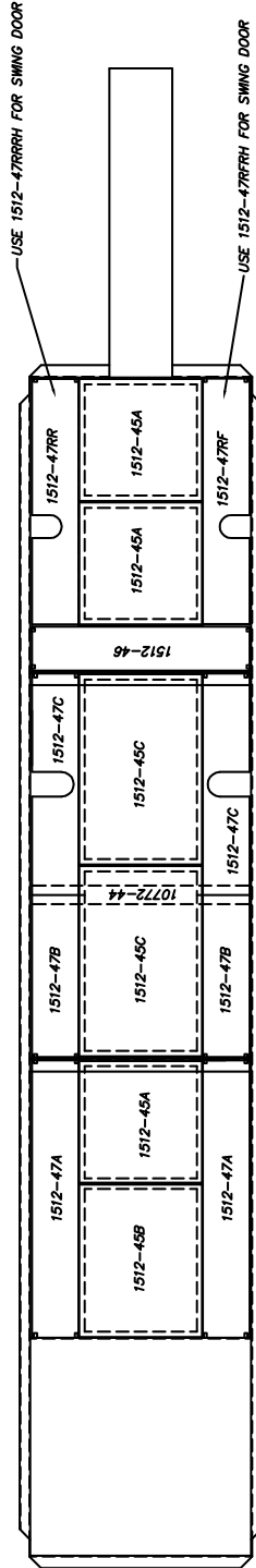

RH PLAN

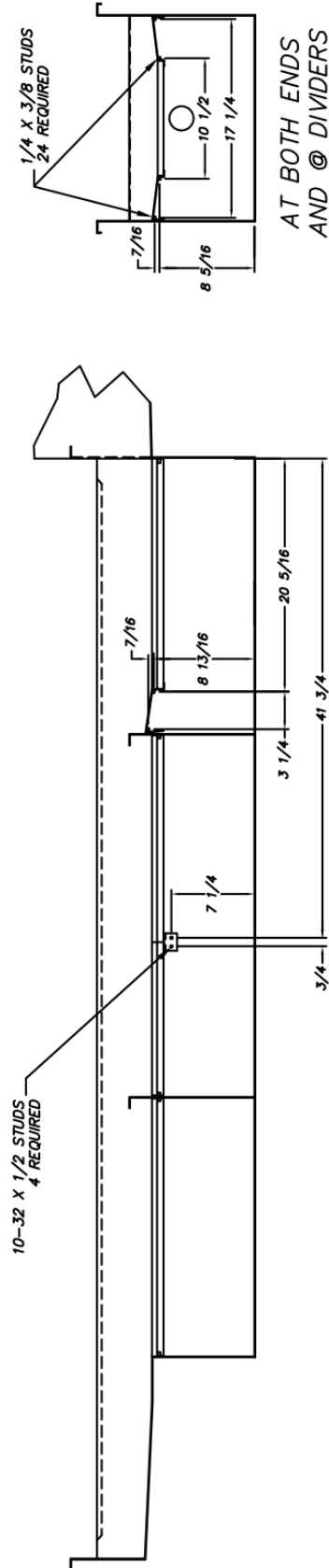

RH ELEVATION, LH OPPOSITE

REV B - 09/11/14

R.H. WASH - L.H. RINSE SHOWN

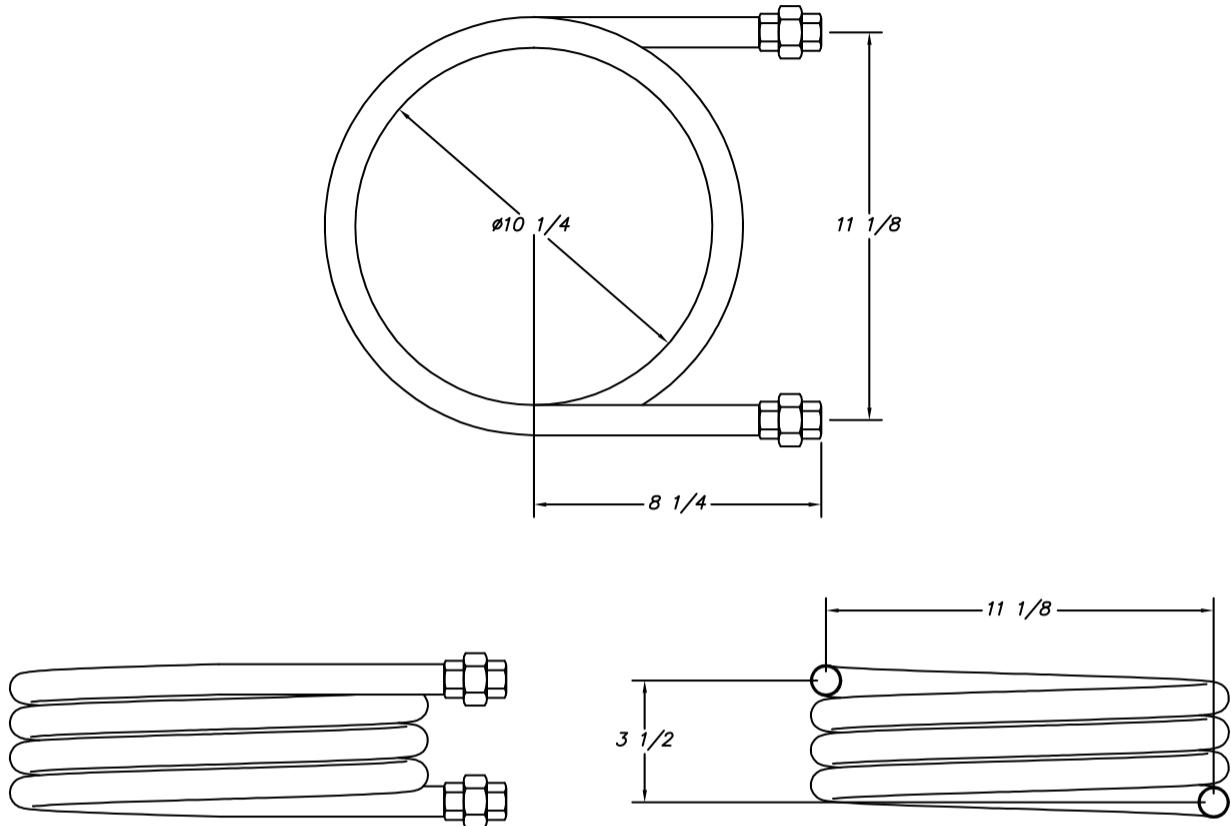

WIND FROM 12 FOOT LENGTH OF TUBING
TRIM TO DIMENSIONS AFTER WINDING

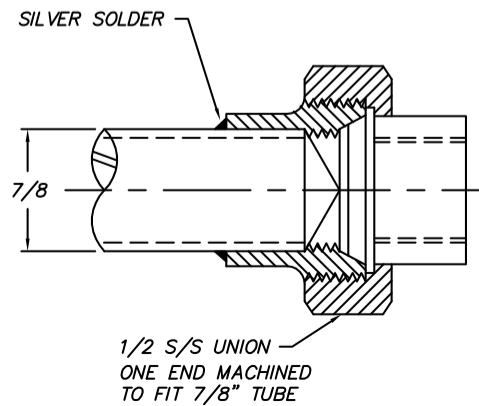

REV A - 03/17/03

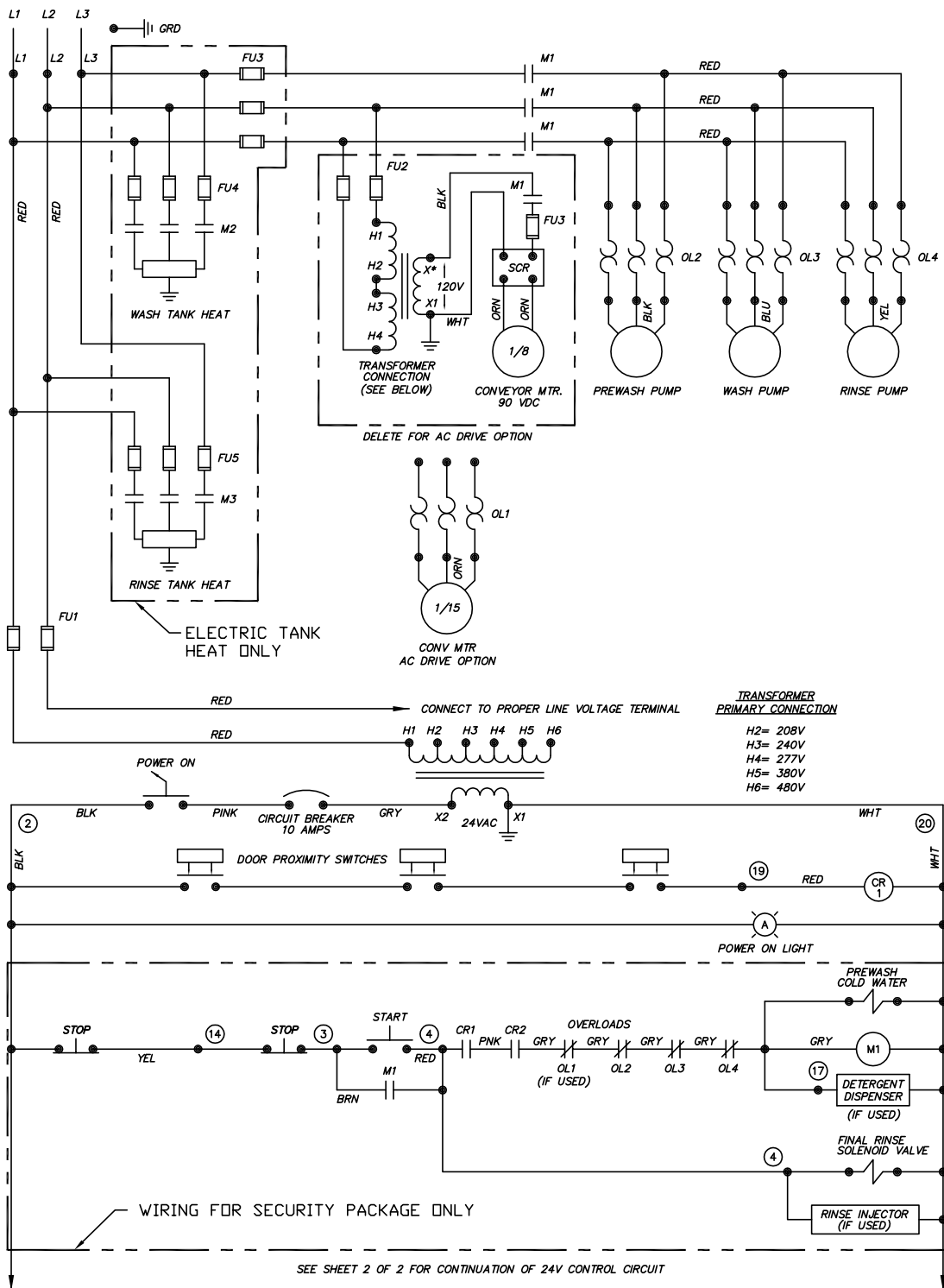
WTRAC024 : TRAC 878 Electric or Steam Heat

DC MOTOR DRY TRANSFORMER CONNECTIONS				
	208 VAC	230 VAC	380 VAC	480 VAC
L1 TO	H1 & H3	H1 & H3	H1	H1
L2 TO	H2 & H4	H2 & H4	H4	H4
X*	X4	X4	X3	X4
	X1 TO X3	X1 TO X3	-	X1 TO X3
	X2 TO X4	X2 TO X4	-	X2 TO X4

SHEET 1 OF 2

C	1988	7.7.03	TITLE	TRAC-878	DWG. NO.	
B	1934	5.8.02		ELECTRIC OR STEAM HEAT	WTRAC024	
A	1917	2.19.0				
REV	ECN NO	DATE				
FILE:	WIRE\WTRAC024			Philadelphia, PA 19135 (215) 624-4800 FAX (215) 624-6966	DRWN/DATE MFJ 3.30.01	

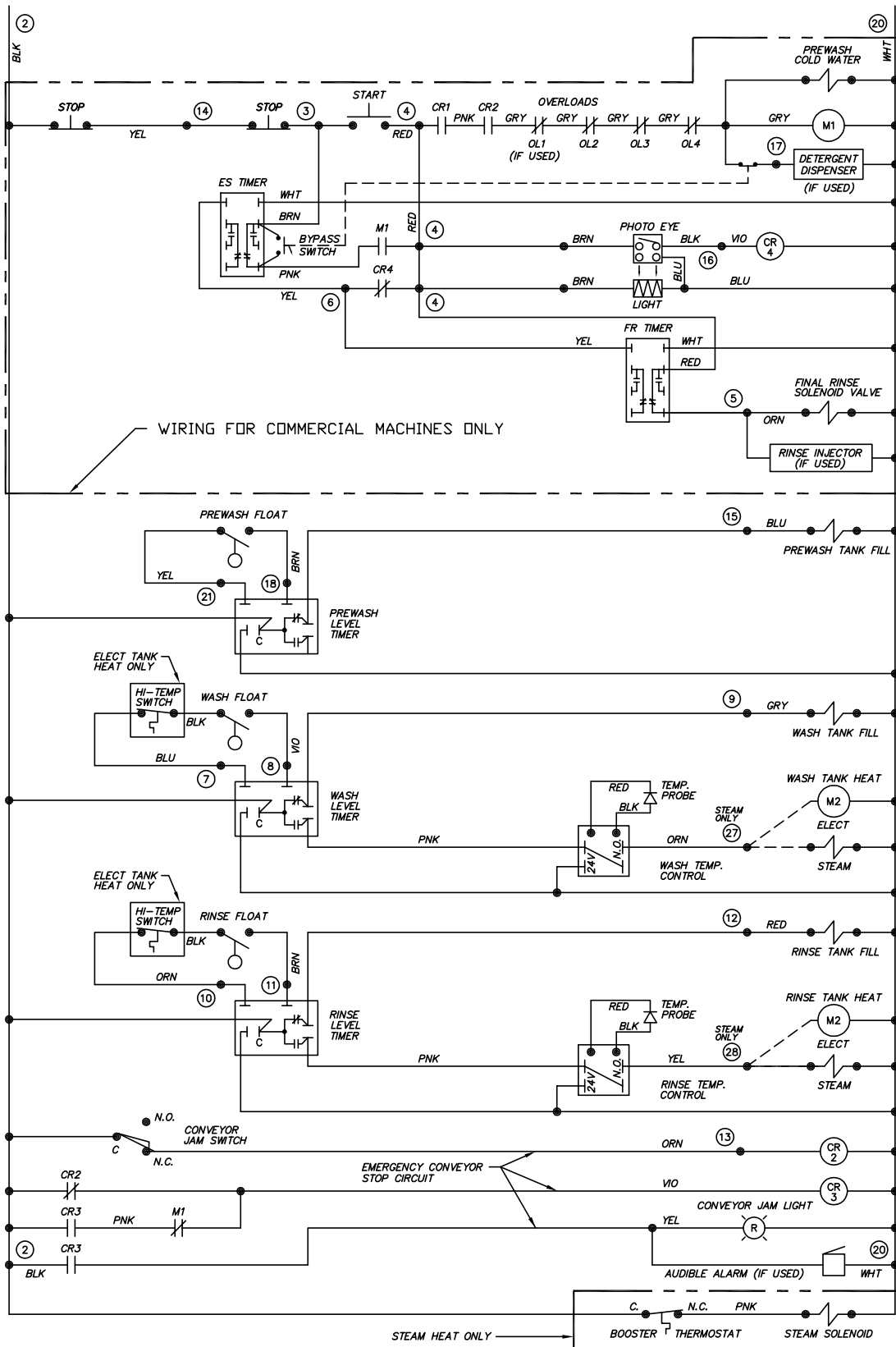

C	1988	7.7.03	TITLE	TRAC-878	DWG. NO.
B	1934	5.8.02		ELECTRIC OR STEAM HEAT	WTRAC024
A	1917	2.19.0			
REV	ECN NO	DATE			
FILE:	WIRE\WTRAC024		Insinger	Philadelphia, PA 19135 (215) 624-4800 FAX (215) 624-6966	DRWN/DATE MFJ 3.30.01

SHEET 2 OF 2

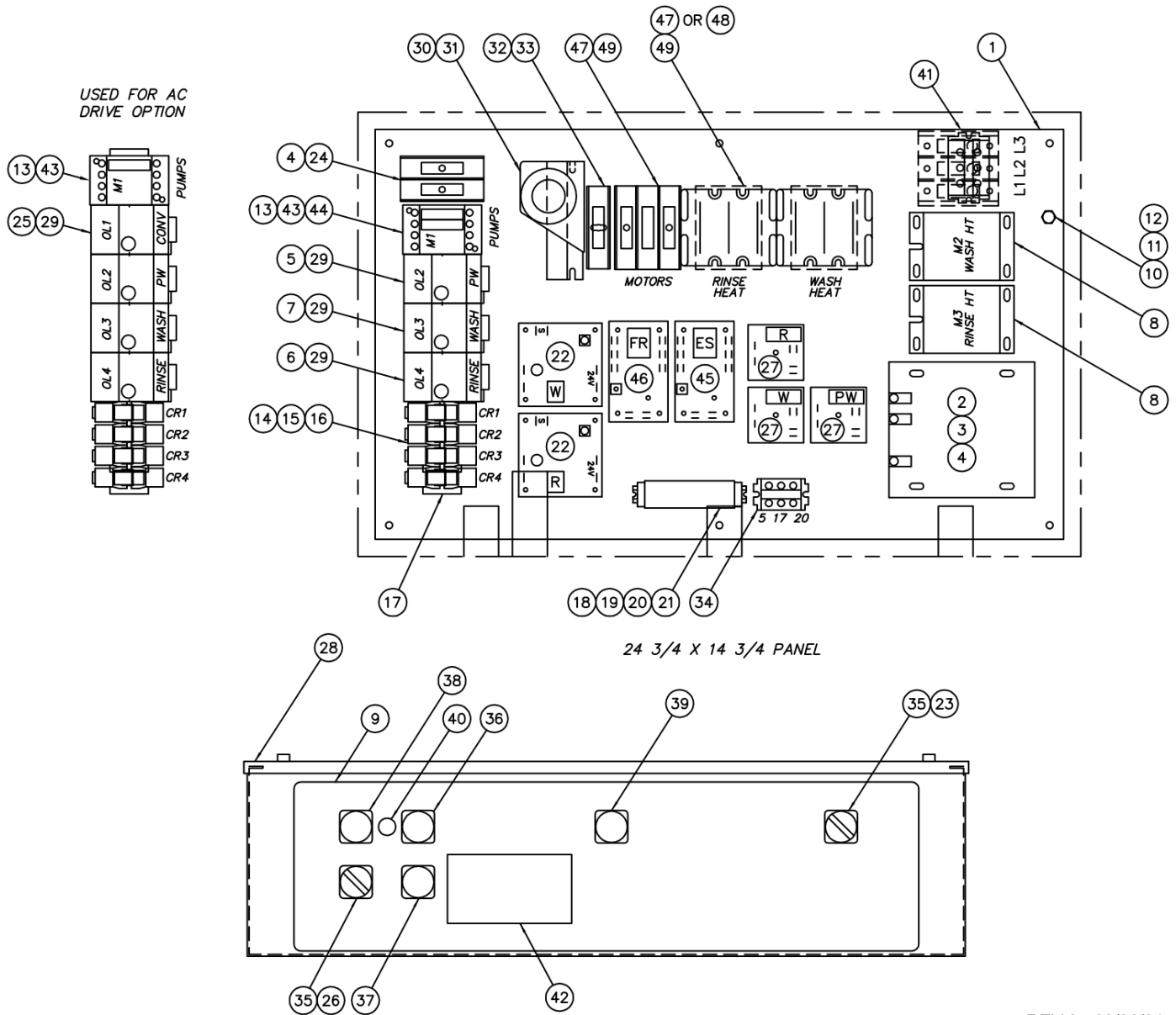
SK-4516 : Control Panel Layout

REV A - 09/26/01

FUSE REQUIREMENTS				
Voltage	208 V	230 V	380 V	460 V
Motors	30 A	30 A	20 A	20 A
Heaters (10kW)	35 A	30 A	20 A	15 A

FUSE PART NO.		
15 A	FNQ-R-15	DE9-183
20 A	FNQ-R-20	5920-02295
25 A	FNQ-R-25	DE9-220
30 A	FNQ-R-30	DE9-227
35 A	JJN-35	DE9-255

PARTS NOT SHOWN		
PART NO.	DESCRIPTION	QTY
	Electric Immersion Heater (5kW)	
DE13-SD73	440 - 480 V, 3 PH	4
DE13-SD53	380 V, 3 PH	
DE13-SD43	220 - 240 V, 3 PH	
DE13-SD23	208 V, 3 PH	
DE5-70	Stop Pushbutton Station	1
DE9-231	Optional Audible Conveyor Jam Alarm	1
DE9-252	Temperature Sensor	2
DE6-26	Transformer, 250 VA (DC Drive Option)	1
DE3-3	Terminal Block (Heaters)	2

SK-4516 : Control Panel Layout

ITEM	PART NO.	DESCRIPTION	QTY
1	SK-4517	Component Mounting Plate	1
2	DE6-25	Control Transformer (250 VA, 24 VAC)	1
3	DE9-165	Fuse Block Kit (250 VA XFMR)	1
4		Fuse (250 VA Transformer Primary)	AR
	DE9-169	460V, FNQ-R-1.8	
	DE9-170	380V, FNQ-R-2	
	DE9-174	220V - 230V, FNQ-R-3.5	
	DE9-175	208V, FNQ-R-4	
5		Overload Relay (1/2 HP Prewash Pump)	1
	DE2-50	460/3/60, 1 - 1.7 A	
	DE2-50	380/3/50, 1 - 1.7 A	
	DE2-52	230/3/60, 1.6 - 2.5 A	
	DE2-52	220/3/50, 1.6 - 2.5 A	
	DE2-52	208/3/60, 1.6 - 2.5 A	
6		Overload Relay (2 HP Rinse Pump)	1
	DE2-53	460/3/60, 2.5 - 4 A	
	DE2-53	380/3/50, 2.5 - 4 A	
	DE2-55	230/3/60, 5.5 - 8 A	
	DE2-55	220/3/50, 5.5 - 8 A	
	DE2-55	208/3/60, 5.5 - 8 A	
7		Overload Relay (3 HP Wash Pump)	1
	DE2-54	460/3/60, 4 - 6 A	
	DE2-54	380/3/50, 4 - 6 A	
	DE2-56	230/3/60, 7 - 10 A	
	DE2-56	220/3/50, 7 - 10 A	
	DE2-56	208/3/60, 7 - 10 A	
8		Contactor (10kW Electric Tank Heater)	2
	DE1-109	460/3/60, 30 A RES	
	DE1-109	380/3/50, 30 A RES	
	DE1-110	230/3/60, 50 A RES	
	DE1-110	220/3/50, 50 A RES	
	DE1-110	208/3/60, 50 A RES	
9	SK-3799	Decal	1
10	D309C-GC-4G	Grounding Stud	1
11	D313C-G5	Lockwasher, 1/4"	1
12	D312C-GC-2	Hex Nut, 1/4-20	1
13		Contactor (Motors)	1
	DE1-93	220 - 460 V, SP4	
	DE1-56AE	208V, SP17	
14	DE2-37	Relay Base	4
15	DE2-38	Relay	4
16	DE3-43	Relay Hold Down Spring	4

SK-4516 : Control Panel Layout

ITEM	PART NO.	DESCRIPTION	QTY
17	DE9-84	DIN Rail (35mm)	1
18	DE3-42	DIN Rail (15mm)	1
19	DE3-39	Terminal Section	AR
20	DE3-40	Terminal End Cover Plate	1
21	DE3-41	Terminal End Clamp	2
22	DE9-251	Temperature Control Board	2
23	DE8-60	Contact Block, NC	1
24	DE9-185	Fuse Block, 2 Pole (DC DRV XFMR)	1
25		Overload Relay (Optional 1/15 HP Conv Drive)	1
	DE2-91	460/3/60, .16 - .25 A	
	DE2-91	380/3/50, .16 - .25 A	
	DE2-92	230/3/60, .25 - .40 A	
	DE2-92	220/3/50, .25 - .40 A	
	DE2-92	208/3/60, .25 - .40 A	
26	DE8-59	Contact Block, NO	1
27	DE7-35	Timer (Liquid Level)	3
28	SK-4518	Control Box, 26 x 16 x 7	1
29	DE2-60	Overload Base	4
30	2M510	DC Drive Control	1
31	1094-115	Potentiometer Bracket	1
32	DE9-42	Fuse Block, 1 Pole (SCR)	1
33	DE9-173	Fuse (SCR), FNQ-R-3	1
34	DE3-9	Terminal Block Assembly	1
35	DE8-58	Selector Switch Assembly	2
36	DE8-64	Pushbutton Assembly, Start	1
37	DE8-65	Pushbutton Assembly, Stop	1
38	DE8-62	Pilot Light Assembly - Yellow	1
39	DE8-61	Pilot Light Assembly - Red	1
40	DE9-106	Circuit Breaker (10A)	1
41		Terminal Block Assembly	1
	DE3-3	380 - 460 V	
	DE3-152	208 - 240 V	
42	SK-3715	Data Decal	1
43	DE1-61AE	Auxiliary Contact, NC	1
44	DE1-62AE	Auxiliary Contact, NO	1
45	DE7-28	Time Delay Board (Energy Saver)	1
46	DE7-27	Final Rinse Timer	1
47	DE9-186	Fuse Block (0 - 30 A)	AR
48	DE9-224	Fuse Block (35 - 60 A)	AR
49	-	Fuse (Single Point Connection)	9

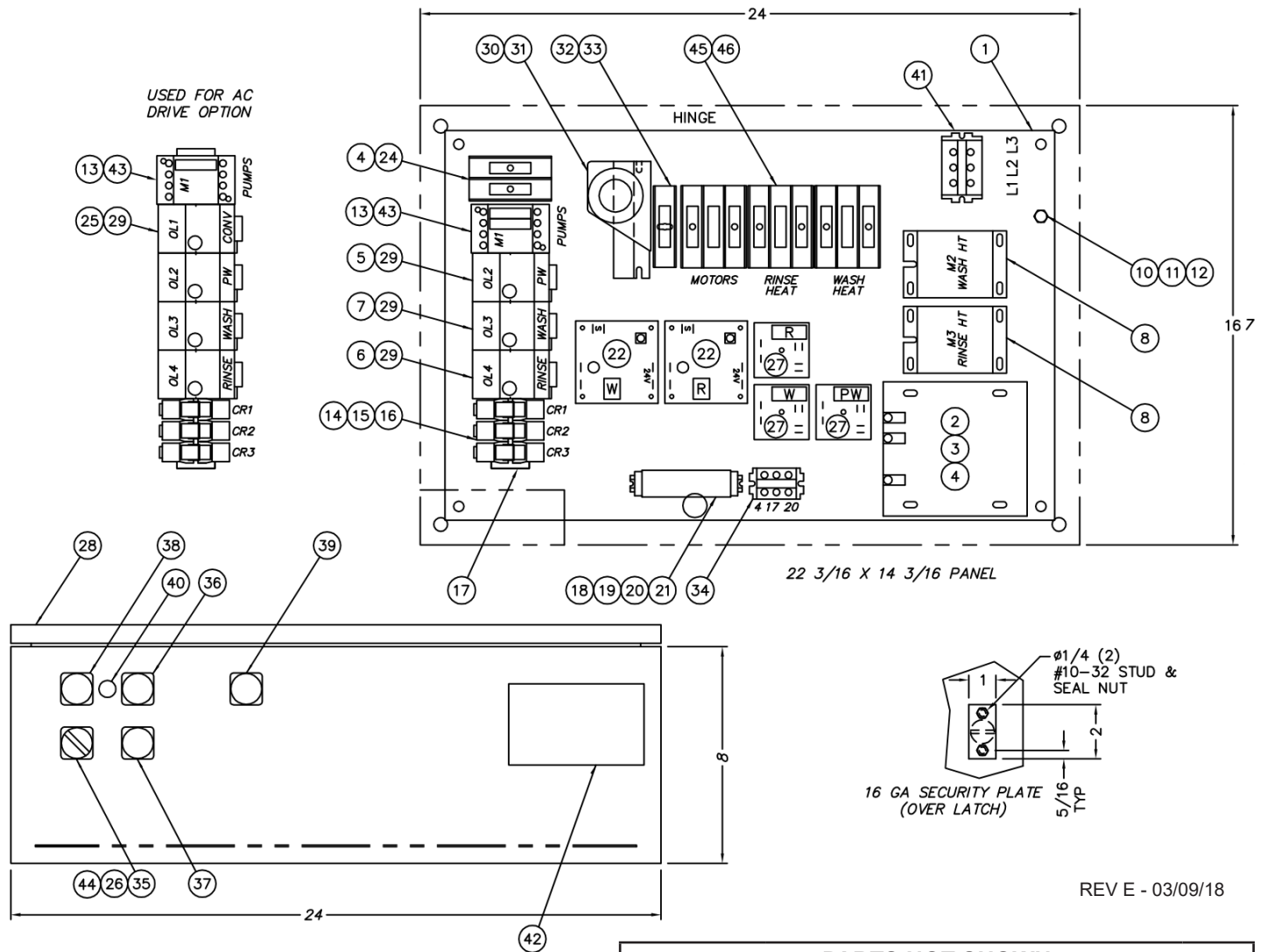
SK-4470 : Control Panel Layout (Security)

REV E - 03/09/18

FUSE REQUIREMENTS				
Voltage	208 V	230 V	380 V	460 V
Motors	30 A	30 A	20 A	20 A
Heaters	30 A	25 A	15 A	15 A

FUSE PART NO.		
15 A	FNQ-R-15	DE9-183
20 A	FNQ-R-20	5920-02295
25 A	FNQ-R-25	DE9-220
30 A	FNQ-R-30	DE9-227

PARTS NOT SHOWN		
PART NO.	DESCRIPTION	QTY
Electric Immersion Heater (3kW)		
DE13-SC73	440 - 480 V, 3 PH	2
DE13-SC53	380 V, 3 PH	
DE13-SC43	220 - 240 V, 3 PH	
DE13-SC23	208 V, 3 PH	
Electric Immersion Heater (5kW)		
DE13-SD73	440 - 480 V, 3 PH	2
DE13-SD53	380 V, 3 PH	
DE13-SD43	220 - 240 V, 3 PH	
DE13-SD23	208 V, 3 PH	
DE5-70	Stop Pushbutton Station	1
DE9-231	Optional Audible Conveyor Jam Alarm	1
DE9-252	Temperature Sensor	2
DE6-26	Transformer, 250 VA (DC Drive Option)	1
DE3-3	Terminal Block (Heaters)	2

SK-4470 : Control Panel Layout (Security)

ITEM	PART NO.	DESCRIPTION	QTY
1	SK-4417	Component Mounting Plate	1
2	DE6-25	Control Transformer (250 VA, 24 VAC)	1
3	DE9-165	Fuse Block Kit (250 VA XFMR)	1
4		Fuse (250 VA Transformer Primary)	AR
	DE9-169	460V, FNQ-R-1.8	
	DE9-170	380V, FNQ-R-2	
	DE9-174	220V - 230V, FNQ-R-3.5	
	DE9-175	208V FNQ-R-4	
5		Overload Relay (1/2 HP Prewash Pump)	1
	DE2-50	460/3/60, 1 - 1.7 A	
	DE2-50	380/3/50, 1 - 1.7 A	
	DE2-52	230/3/60, 1.6 - 2.5 A	
	DE2-52	220/3/50, 1.6 - 2.5 A	
	DE2-52	208/3/60, 1.6 - 2.5 A	
6		Overload Relay (2 HP Rinse Pump)	1
	DE2-53	460/3/60, 2.5 - 4 A	
	DE2-53	380/3/50, 2.5 - 4 A	
	DE2-55	230/3/60, 5.5 - 8 A	
	DE2-55	220/3/50, 5.5 - 8 A	
	DE2-55	208/3/60, 5.5 - 8 A	
7		Overload Relay (3 HP Wash Pump)	1
	DE2-54	460/3/60, 4 - 6 A	
	DE2-54	380/3/50, 4 - 6 A	
	DE2-56	230/3/60, 7 - 10 A	
	DE2-56	220/3/50, 7 - 10 A	
	DE2-56	208/3/60, 7 - 10 A	
8		Contactors (8kW Electric Tank Heater)	2
	DE1-109	30 A Res	
	DE1-109	30 A Res	
	DE1-109	30 A Res	
	DE1-109	30 A Res	
	DE1-109	30 A Res	
9	-	-	-
10	D309C-GC-4G	Grounding Stud	1
11	D313C-G5	Lockwasher, 1/4"	1
12	D312C-GC-2	Hex Nut, 1/4-20	1
13		Contactors (Motors)	1
	DE1-56AE	220 - 460 V,	
	DE1-55AE	208V,	
14	DE2-37	Relay Base	3
15	DE2-38	Relay	3
16	DE3-43	Relay Hold Down Spring	3

SK-4470 : Control Panel Layout (Security)

ITEM	PART NO.	DESCRIPTION	QTY
17	DE9-84	DIN Rail (35mm)	1
18	DE3-42	DIN Rail (15mm)	1
19	DE3-39	Terminal Section	AR
20	DE3-40	Terminal End Cover Plate	1
21	DE3-41	Terminal End Clamp	2
22	DE9-251	Temperature Control Board	2
23	-	-	-
24	DE9-185	Fuse Block, 2 Pole (DC DRV XFMR)	1
25		Overload Relay (Optional 1/15 HP Conv Drive)	1
	DE2-91	460/3/60, .16 - .25 A	
	DE2-91	380/3/50, .16 - .25 A	
	DE2-92	230/3/60, .25 - .40 A	
	DE2-92	220/3/50, .25 - .40 A	
	DE2-92	208/3/60, .25 - .40 A	
26	DE8-59	Contact Block, NO	1
27	DE7-35	Timer (Liquid Level)	3
28	DE9-248	Control Box, 24 x 16 x 8	1
29	DE2-60	Overload Base	AR
30	2M510	DC Drive Control	1
31	1094-115	Potentiometer Bracket	1
32	DE9-42	Fuse Block, 1 Pole (SCR)	1
33	DE9-173	Fuse (SCR), FNQ-R-3	1
34	DE3-9	Terminal Block Assembly	1
35	DE8-58	Selector Switch Assembly	1
36	DE8-64	Pushbutton Assembly, Start	1
37	DE8-65	Pushbutton Assembly, Stop	1
38	DE8-62	Pilot Light Assembly - Yellow	1
39	DE8-61	Pilot Light Assembly - Red	1
40	DE9-106	Circuit Breaker (10A)	1
41		Terminal Block Assembly	1
	DE3-152	380 - 460 V	
	DE3-152	208 - 240 V	
42	SK-3715	Data Decal	1
43	DE1-120	Auxiliary Contact, NC & NO	1
44	DE5-35	Auxiliary Contact, NO	5Q
45	DE9-186	Fuse Block (Single Pt. Conn. w/ Elect. Tank Heat)	3
46	-	Fuse (Single Pt. Conn. w/ Elect. Tank Heat)	9



Insinger Machine Company
6245 State Road
Philadelphia, PA 19135-2996

800-344-4802
Fax 215-624-6966
www.insingermachine.com